



Operating Instructions and Parts Manual 20-inch Planer

Models 209BHH, 209BHH-3, and 209BHH-4



Powermatic
427 New Sanford Road
La Vergne, TN 37086
Ph.: 855-657-GOLD
www.powermatic.com

Part No. M-PM1-478
Edition 2 04/2026
Copyright ©2026 Powermatic



1.0 IMPORTANT SAFETY INSTRUCTIONS

⚠ WARNING

– To reduce risk of injury:

1.1 General Safety

1. Read and understand this manual, all safety information, and safety labels before operating the planer. Know the limitations and hazards associated with this machine.
2. Make certain that the machine frame is electrically grounded and that a ground lead is included in the incoming electrical service. In cases where a cord and plug are used, make certain that the grounding plug connects to a suitable ground. Follow the grounding procedure indicated in the National Electrical Code.
3. Use the planer only for its intended purpose and only with manufacturer-recommended accessories and parts. If used for other purposes, Powermatic disclaims any real or implied warranty and holds itself harmless for any injury or damage which may result from that use.
4. Only trained and authorized operators may use this planer. If you are not thoroughly familiar with the operation of this planer, obtain direction from your supervisor, instructor, or other qualified person.
5. Keep children and untrained persons away from the work area.
6. Never operate the machine while tired, distracted, or under the influence of drugs, alcohol, or medication.
7. Keep the machine guards in place for every operation for which they should be used. If any guards are removed for maintenance, DO NOT OPERATE the machine until the guards are reinstalled.

1.2 Workplace Safety

1. Keep floors clean and dry. Remove sawdust, scraps, oil, and trip hazards. Provide adequate lighting and workspace.
2. Position the planer and manage workflow so operators and bystanders are not in the line-of-fire of potential kickback.
3. Wear proper apparel. Before operating machine, remove tie, rings, watch, and other jewelry. If wearing long sleeves, roll sleeves

up above the elbows. Remove all loose outer clothing. Tie back/contain long hair. Wear protective, non-slip footwear.

4. Eye protection: Wear ANSI-approved safety glasses; use a face shield where appropriate. Ordinary eyeglasses are not safety glasses.
5. Hearing protection: Wear hearing protection when operating or observing planing operations.
6. Respiratory protection and dust control: Use an effective dust collection system with a minimum capacity of 900 CFM. Wear a properly fitted respirator/dust mask appropriate for wood dust exposure.

1.3 Before Planer Operation

1. Verify guards, covers, and safety devices are installed, undamaged, and functional before startup.
2. Ensure the power switch is OFF before connecting power.
3. Remove all adjusting tools, wrenches, and loose items from the machine before startup.
4. Confirm cutter inserts/knives are sharp, undamaged, correctly installed, and securely fastened (use specified torque where provided).
5. Be sure cutterhead rotates under power in a counterclockwise direction when viewed from the main drive motor side.
6. Inspect stock. Do not plane workpieces containing nails, staples, loose knots, or foreign material. Knife impact on these objects can cause the knives to be pulled out and cause them to shatter against the chipbreaker or pressure bar. Twisted, warped, or in wind stock should first be jointed on one surface before attempting to plane a parallel surface on the planer. Serious stock flaws cannot be removed by use of a planer alone.
7. Follow size and depth limits: do not exceed maximum depth of cut; do not plane below minimum stock length/thickness.
8. If your planer uses anti-kickback fingers, verify they move freely and are clean; do not operate if they do not function correctly.

1.4 During Planer Operation

1. Maintain a balanced stance. Stand to one side of the infeed/outfeed path to reduce the risk of injury from kickback. Make sure no one is standing in line with the infeed table.
2. Never start the planer with the workpiece touching the cutterhead. Allow the

- cutterhead to reach full speed before feeding stock.
3. Do not force-feed stock. Let the feed rollers control the feed rate.
 4. Keep hands, fingers, clothing, and hair away from infeed rollers and all moving parts. Never reach into the machine while running.
 5. Give the work you are doing your undivided attention. Looking around, carrying on a conversation, and "horseplay" are careless acts that can result in serious injury.
 6. Do not plane more than one workpiece at a time unless the manufacturer explicitly permits and describes safe spacing/conditions.
 7. Do not change feed speed while a board is being planed.
 8. Support long or heavy workpieces with auxiliary stands/tables to prevent tipping and loss of control.
 9. Plane with the grain (or at a slight angle). Avoid planing across the grain and avoid end grain.
 10. Do not look inside the planer while it is operating (chips can fly at high speed).
 11. If stock becomes stuck or a jam occurs, turn OFF the planer, wait for complete stop, disconnect power, and only then clear the jam.
 12. Never leave the planer running unattended. Turn OFF and wait for complete stop before leaving the area.

1.5 Service and Maintenance Safety

1. Use only Powermatic or factory-authorized replacement parts and accessories; otherwise, the warranty and guarantee are null and void.
2. Keep tools sharp and clean for safe, optimal performance. Dull tools increase noise levels and can cause kickbacks and glazed surfaces. Check the condition and adjustment of the tools before making any cuts.
3. Except when adjusting feed rate, disconnect the machine from power before any cleaning, maintenance, adjustments, knife insert changes, or servicing.

4. A machine under repair should be RED TAGGED to show it should not be used until the maintenance is complete.
5. Use cut-resistant gloves when handling knife inserts. Edges are extremely sharp.
6. Verify all fasteners (knife insert screws) are secure after servicing. Loose knife inserts can be ejected at high speed and cause serious injury or death.
7. Use only the correct tools and tightening method for knife inserts. Avoid overtightening.
8. Keep anti-kickback fingers clean and freely moving. Replace damaged components. Do not operate if the anti-kickback device is not functioning.
9. Allow hot components (e.g., belts/pulleys) to cool before servicing.
10. Clean using safe methods. Do not clear chips and sawdust with your hands. Use a brush or vacuum where possible. If using compressed air, wear eye protection and avoid directing debris toward others. If compressed air is used for cleaning, reduce pressure to <30 psi.
11. Never bypass, disable, or defeat any guard, cover, limit switch, or safety device.
12. After maintenance, remove all tools/wrenches from the machine before reconnecting power and restarting.

 **WARNING:** This product can expose you to chemicals including lead which is known to the State of California to cause cancer and birth defects or other reproductive harm. For more information go to <http://www.p65warnings.ca.gov>.

 **WARNING:** Drilling, sawing, sanding or machining wood products generates wood dust and other substances known to the State of California to cause cancer. Avoid inhaling dust generated from wood products or use a dust mask or other safeguards for personal protection. Wood products emit chemicals known to the State of California to cause birth defects or other reproductive harm. For more information go to <http://www.p65warnings.ca.gov/wood>.

Familiarize yourself with the following safety notices used in this manual:

 **CAUTION** This means that if precautions are not heeded, it may result in minor injury and/or possible machine damage.

 **WARNING** This means that if precautions are not heeded, it may result in serious, or possibly even fatal, injury.

2.0 Table of Contents

Section	Page
1.0 IMPORTANT SAFETY INSTRUCTIONS	2
1.1 General Safety	2
1.2 Workplace Safety	2
1.3 Before Planer Operation.....	2
1.4 During Planer Operation.....	2
1.5 Service and Maintenance Safety.....	3
2.0 Table of Contents	4
3.0 About this Manual	5
4.0 Features	6
5.0 Specifications	7
Specifications	7
6.0 Setup and Assembly	8
6.1 Shipping Contents	8
6.2 Unpacking	9
6.3 Installing	9
6.3.1 Table Height Handwheel	9
6.3.2 On/Off Switch Box	9
6.3.3 Extension Tables.....	10
6.3.4 Dust Hood	10
6.4 Dust Collection	10
6.5 Knife Inspection.....	10
7.0 Electrical Connections.....	11
7.1 Converting from 230V to 460V	11
7.2 Extension Cords	11
8.0 Digital Readout Control	11
8.1 DRO Mode	12
8.2 Calibration Mode	12
9.0 Adjustments	12
9.1 Belt Tensioning.....	13
9.2 Pulley Alignment.....	13
9.3 Table Rollers	13
9.4 Cutterhead.....	14
9.5 Adjusting or Replacing Rotating Knife Inserts	14
9.6 Work Table Parallel to Cutterhead	15
9.7 Transmitting Rollers, Chipbreaker, and Pressure Bar.....	16
9.7.1 Anti-Kickback Fingers.....	16
9.7.2 Infeed and Outfeed Roller Spring Tension	16
9.7.3 Height of Infeed Roller, Chipbreaker, Pressure Bar, and Outfeed Roller.....	16
Infeed Roller Height Adjustment.....	17
Chipbreaker Height Adjustment	17
9.8 Feed Speed Control	18
9.9 Depth of Cut Adjustment	19
10.0 Operation	19
10.1 General Recommendations.....	19
10.2 Basic Operating Procedure	20
10.3 ON/OFF Switch	20
10.4 Before Planing a Workpiece.....	20
10.5 Planing Workpieces.....	20
10.6 Planing Warped Wood	21
10.7 Grain Direction	21
10.8 Knots and Trouble Spots.....	22
10.9 Snipe	22
10.10 Ridges	22
10.11 Planing Rough Lumber.....	22
10.12 Planing Glued-Up Boards.....	23
11.0 Maintenance.....	23
11.1 Inspection and General Cleaning	23
11.2 Lubrication.....	23
11.0 Troubleshooting	25

Operating Problems	25
Mechanical and Electrical Problems	26
12.0 Replacement Parts.....	28
12.1.1 Table Assembly – Exploded View	28
12.1.2 Table Assembly – Parts List.....	28
12.2.1 Cutterhead Assembly – Exploded View	29
12.2.2 Cutterhead Assembly – Parts List.....	30
12.3.1 Base Assembly – Exploded View.....	32
12.3.2 Base Assembly – Parts List.....	33
12.4.1 Gearbox Assembly – Exploded View	34
12.4.2 Gearbox Assembly – Parts List	35
12.5.1 Cabinet Assembly – Exploded View.....	36
12.5.2 Cabinet Assembly – Parts List	37
13.0 Electrical Connections.....	38
14.0 Warranty and Service.....	41
Preventive Maintenance Checklist.....	42

3.0 About this Manual

This manual, provided by Powermatic, covers the safe operation and maintenance procedures for Powermatic Models 209BHH, 209BHH-3, and 209BHH-4 planers. This manual contains instructions for installation, safety precautions, general operating procedures, maintenance, and a parts breakdown. This machine is designed and constructed to provide consistent, long-term operation if used in accordance with the instructions set forth in this manual. If there are any questions or comments, please contact either your local supplier or Powermatic. Powermatic can also be reached at our website: www.powermatic.com.

Register your product using the mail-in card provided or register online:

www.powermatic.com/product-registration

To quickly reach the product registration webpage, scan the QR code below.



4.0 Features

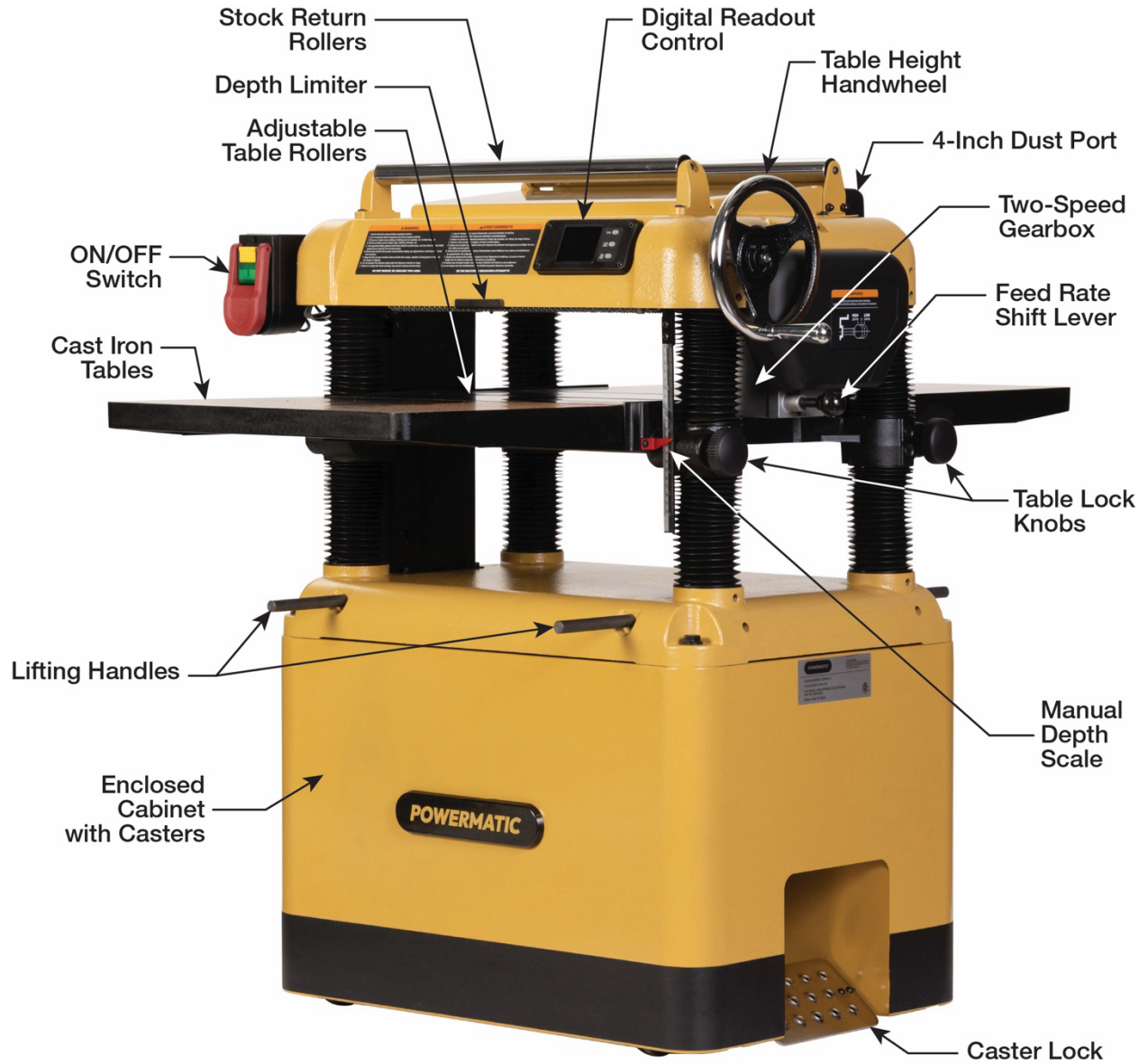

Figure 4-1

5.0 Specifications

Specifications

	209BHH	209BHH-3* / 209BHH-4**
Model Number.....	209BHH	209BHH-3* / 209BHH-4**
Stock Number	PM1-478	PM1-479 / PM1-480
Main Table Area (L x W)	21-1/2" x 20"	21-1/2" x 20"
Full Table Area (L x W)	51-1/2" x 20"	51-1/2" x 20"
Maximum Workpiece Width	20"	20"
Maximum Workpiece Thickness	8"	8"
Minimum Workpiece Thickness	1/8"	1/8"
Maximum Full Width Cutting Depth.....	3/32"	3/32"
Minimum Workpiece Length.....	8"	8"
Table Movement Per 1 Rev. of Handwheel	0.062" (1.6mm)	0.062" (1.6mm)
Helical Cutter Head	4 rows, 68 four-sided inserts	4 rows, 68 four-sided inserts
Knives Size (L x W x T).....	0.59" x 0.59" x 0.10"	0.59" x 0.59" x 0.10"
Cutterhead Speed (RPM).....	5,200	5,200
Cutterhead Diameter (in.).....	3-1/4	3-1/4
Knife Insert Screw Max. Torque (pound force–inch).....	45 to 55	45 to 55
Sound Rating @ 20" distance (dB)	80 to 84	80 to 84
Feeding Rate (2 Speeds).....	16 & 28 FPM	16 & 28 FPM
Dust Chute Diameter.....	4"	4"
Dust Collector Minimum CFM	900	900
Motor	5HP, 1Ph, 20A, 60Hz, 2P, 230V	5HP, 3Ph, 13.5/6.7A, 60Hz, 2P, 230/460V
Recommended Circuit Size (Amps.)	40	40
Internal Power Cable.....	SJT, 12AWG	SJT, 14AWG
Motor Power Cable	SJT, 12AWG	SJT, 14AWG
Overall Dimensions (LxWxH).....	51-1/2" x 37-3/8" x 43-3/8"	26 x 36-5/8 x 41-3/8
Net Weight (lbs.)	606 lbs.	606 lbs.
Shipping Weight (lbs.).....	704 lbs.	704 lbs.

* 209BHH-3 is pre-wired 230V and can be converted to 460V operation. **NOTE:** For 460V operation, magnetic switch (part no.PM1-538) must be purchased separately and installed. Also, change the transformer fuse position from "230V" to "460V". Refer to the 460V Electrical Connections diagram in this manual. A qualified electrician is recommended. See "Section 7.1 Converting from 230V to 460V."

** 209BHH-4 is pre-wired for 460V operation.

The above specifications were current at the time this manual was published, but under our policy of continuous improvement, Powermatic reserves the right to change specifications at any time and without prior notice, without incurring any obligations.

WARNING

Read and understand the entire contents of this manual before attempting assembly or operation. Failure to comply may cause serious injury.

6.0 Setup and Assembly

6.1 Shipping Contents

- 1 Planer (not shown)
- 1 Dust hood
- 2 Cast iron extension tables
- 1 Handwheel
- 1 Handle
- 4 Hex wrenches (3, 4, 5 and 6mm)*
- 2 Open-end wrenches (10-13, 12-14, 17-19mm)*
- 3 Bags of fasteners* – see below
- 1 Owner's manual (not shown)
- 1 Warranty card (not shown)
- 1 1/4" Drive Screwdriver
- 2 T25 Torx Screwdriver
- 1 Set of 10 Knife Inserts and screws

Contents of fastener bags* (Figure 3):

- A – (for installing handwheel)
 - 1 Direction label
 - 1 Hex nut
 - 1 Flat washer
 - 1 Key
- B – (for installing extension tables)
 - 6 Hex cap screws, M8x25
 - 6 Socket set screws, M8x20
 - 1 Socket set screw, M8x25
- C – (for installing dust hood)
 - 6 Hex cap screw w/flat washer, M6x1.0Px12

Tools Required for Assembly:

- Forklift or hoist with slings
- 10,13, 14, 19mm open-end wrenches
- 4mm hex wrenches (provided)



Figure 6-1

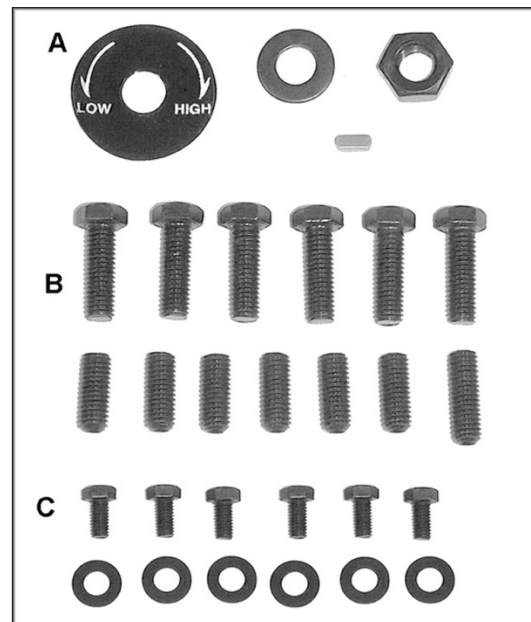

Figure 6-2

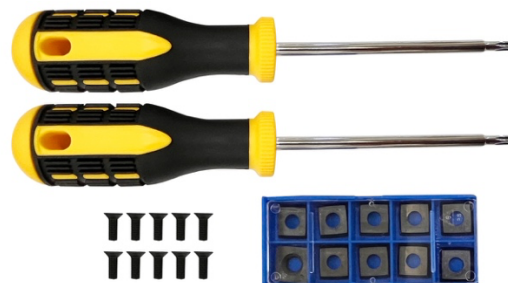

Figure 6-3

6.2 Unpacking

1. Remove all contents from shipping carton. Do not discard carton or packing material until planer is assembled and running satisfactorily.
2. Inspect the contents for shipping damage or missing parts. If either is discovered, report it immediately to your distributor.

6.3 Installing

Remove the screws holding the planer to the pallet and use a forklift or hoist to lift the planer off the pallet. Forks and straps should always be placed under the four lifting handles when lifting this machine (see Figure 6-4). The lifting handles can be pushed back in when not in use.

The planer should be operated in a well-lit area with a sturdy floor and good ventilation. It can be rolled to the desired location on its casters. Press the foot pedal down to lock and prevent movement during operation or adjustments (see Figure 6-5).

Exposed surfaces, such as tables, rollers, cutterhead, etc., have been given a protective coating at the factory. This should be removed with a soft cloth moistened with a good commercial solvent. Do not use acetone, gasoline, lacquer thinner, or other solvents with a low flash point. Do not use an abrasive pad because it may scratch the polished cast iron surfaces.

⚠ WARNING Use care when handling knife inserts and cleaning around the cutterhead area – knife inserts are extremely sharp.

Leave sufficient space around the planer for complete processing of boards through infeed and outfeed sides.

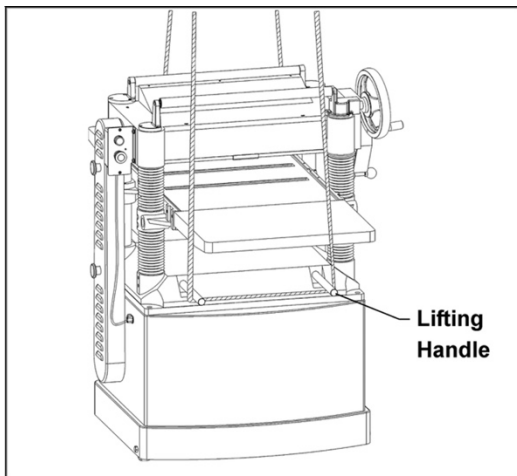

Figure 6-4



Figure 6-5: Caster Foot Pedal in Locked Position

6.3.1 Table Height Handwheel

Follow the instructions below to install the Table Height Handwheel. Refer to Figure 6-6.

1. Remove the nut and washer from the gearbox shaft and place the handwheel onto the shaft, making sure it is oriented so the handwheel slips over the key.
2. Place flat washer and hex nut on shaft and tighten with 19mm wrench.
3. Mount the handle into the threaded hole in the handwheel and tighten with a 14mm wrench placed over the flat on the handle.

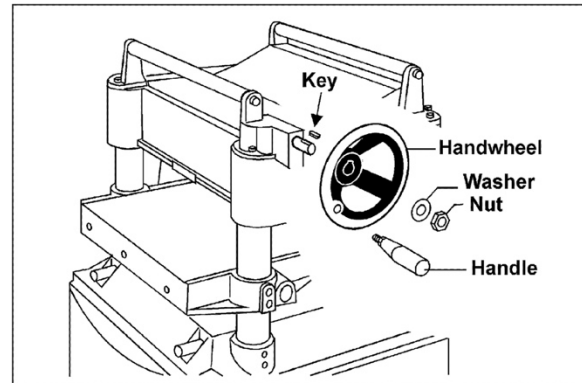

Figure 6-6

6.3.2 On/Off Switch Box

Follow the instructions below to install the On/Off Switch Box. Refer to Figure 6-7.

1. There are two hex cap screws with flat washers mounted to the head casting. Use a 10mm open-end wrench to remove these screws and washers.
2. Mount the On/Off Switch Box using the screws and washers removed in step 1.



Figure 6-7

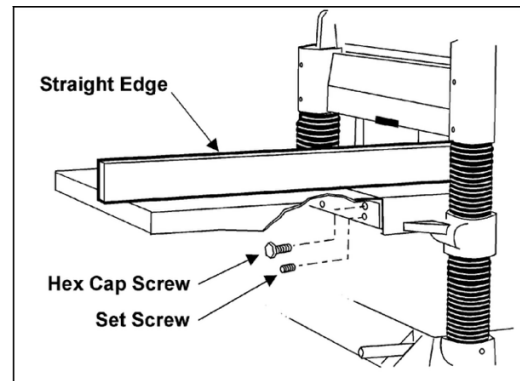

Figure 6-8

6.3.3 Extension Tables

Follow the instructions below to install the Infeed and Outfeed Tables. Refer to Figure 6-8.

1. Using a 4mm hex wrench, install the longer set screw (25mm) into the middle hole of the main table. This will serve as a locating screw.
2. Install an extension table to the edge of the main table by passing the middle mounting hole over the locating screw.
3. Using a 13mm open wrench, install 2 of 3 hex cap screws into the left and right mounting holes. Do not tighten screws.
4. Remove the center locating screw and install the third hex cap screw in the middle mounting hole. Do not tighten screw.
5. The extension table must be leveled with the main table. Place a straight edge (such as a jointed board) across the extension table and the main table.

NOTE: The straight edge should not lie over the raised table rollers, as this would distort the leveling process. Either place the straight edge just short of the table rollers or lower the table rollers completely into the table (see *Section 9.3, Table Rollers*) while mounting the extension tables.

6. Insert three socket set screws with a 4mm hex wrench and screw them in or out as needed until tables are level.
7. Securely tighten the three hex cap screws.
8. Mount and level the second extension table to the opposite side of the planer table, using the same procedure.

6.3.4 Dust Hood

Follow the instructions below to install the Dust Hood. Refer to Figure 6-9.

IMPORTANT: Powermatic recommends using a dust collection system with this planer. If you are not using a dust collection system, do not attach the dust hood to the planer. The accumulation of dust inside the hood may create a safety hazard or eventually cause the rollers to jam.

1. Mount the dust hood to the rear of the head casting with six M6 x 12 hex cap screws with flat washers. Note: The dust hood can be mounted so the dust port angles in either direction.

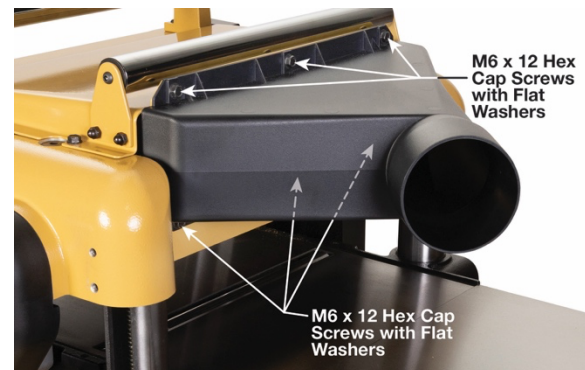

Figure 6-9

6.4 Dust Collection

It is strongly recommended that a dust collection system be used with this planer, with a minimum capacity of 900 CFM.

NOTE: A dryer vent hose is not acceptable for collecting wood dust and chips.

IMPORTANT: If you are not using a dust collection system, do not attach the dust hood to the planer. The accumulation of dust inside the hood may create a safety hazard or eventually cause the rollers to jam.

6.5 Knife Inspection

The knife inserts in the cutterhead are secured in position by the manufacturer. However, the operator should confirm that each knife insert is tight before

operating the planer. See *Section 9.5, Adjusting or Replacing Rotating Knife Inserts*.

⚠ WARNING Check the tightness of all knife inserts in the cutterhead before operating the planer. Loose knife inserts can be ejected from the cutterhead at high speed, causing serious injury.

7.0 Electrical Connections

⚠ WARNING Electrical connections must be made by a qualified electrician in compliance with all relevant codes. The machine must be properly grounded to help prevent electrical shock and possible fatal injury.

Models 209BHH and 209BHH-3 is wired for 230-volt power. Model 209BHH-4 is wired for 460V. The planer has an electrical junction box on the cabinet. Connect the planer to the power source through this junction box.

The planer should be connected to a dedicated circuit and protected by a circuit breaker or time delay fuse, with a minimum amp rating of 40A. **Local codes take precedence over recommendations.**

This machine must be grounded. Grounding provides a path of least resistance to help divert current away from the operator in case of an electrical malfunction.

⚠ WARNING Check with a qualified electrician or service personnel if the grounding instructions are not fully understood, or if you are in doubt about whether the tool is properly grounded. Failure to comply may cause serious or fatal injury.

Make sure the voltage of your power supply matches the specifications on the machine's motor plate.

7.1 Converting from 230V to 460V

Model 209BHH-3 (PM1-479) is factory wired for 230V operation but can be converted to 460V operation.

1. Change leads in motor junction box, as shown in electrical diagrams.
2. Replace 230V magnetic switch with 460V magnetic switch (part no. PM1-538; separate purchase). Also, change the transformer fuse position from "230V" to "460V". Refer to the 460V Electrical Connections diagram in this manual. A qualified electrician is recommended.

7.2 Extension Cords

Powermatic does not recommend using an extension cord for this machine. If an extension cord is necessary, make sure the cord rating is suitable for the amperage listed on the machine's motor plate. An undersized cord will cause a drop in line voltage, resulting in power loss and overheating.

Table 1 shows the recommended sizes based on cord length and nameplate amperage rating. If in doubt, use the next heavier gauge. The smaller the gauge number, the heavier the cord.

Recommended Gauges (AWG) of Extension Cords

Amps	Extension Cord Length *					
	25 feet	50 feet	75 feet	100 feet	150 feet	200 feet
< 5	16	16	16	14	12	12
5 to 8	16	16	14	12	10	NR
8 to 12	14	14	12	10	NR	NR
12 to 15	12	12	10	10	NR	NR
15 to 20	10	10	10	NR	NR	NR
21 to 30	10	NR	NR	NR	NR	NR

*based on limiting the line voltage drop to 5V at 150% of the rated amperes.

NR: Not Recommended.

Table 1: Extension Cord Recommendations

8.0 Digital Readout Control

This planer has a digital readout control (DRO) that assists with precise bed adjustments. You must first calibrate the DRO before use. See *Section 8.2 Calibration Mode* to calibrate DRO.

NOTE: The DRO enters sleep mode if inactive for 10 minutes. Touch any DRO button or turn the table height handwheel to wake-up the DRO.

The DRO has two modes:

DRO Mode (Figure 8-1): Shows the table's position relative to the calibration settings you set.

Calibration Mode (Figure 8-2): Enter "Calibration Mode" to set DRO in relation to where you have the bed position. When in Calibration Mode, the three button functions change to the orange prompts on the right side of the screen.



Figure 8-1: In DRO Mode



Figure 8-2: In Calibration Mode

8.1 DRO Mode

In DRO Mode, the screen shows the bed position.

CAL: Press and hold this button to enter “Calibration Mode”. After adjusting the DRO settings, press this button again to save your settings and return to “DRO Mode”.

Inch/mm: Press this button to toggle between Imperial and Metric measurements on the display. While in “DRO Mode”, switch between Imperial and Metric measurements.

INC/ABS: Press this button to toggle between Absolute Value (ABS) and Incremental Value (INC). The lower-left area of the display will show which one is selected. When Incremental Value (INC) is selected, you can press and release the CAL button to zero the bed height at that point. This is useful when you want to remove a specific amount of material from a workpiece.

8.2 Calibration Mode

You can enter Calibration Mode only when the display shows Absolute Value (ABS). Press the INC/ABS button until “ABS” is shown in the lower left area of the display. Next, press and hold the CAL button until the DRO enters Calibration Mode. At this point, an orange banner will be at the top of the screen and orange function markers will be on the right side of the screen. The three button functions change to what is on the orange function markers.

Starting from the bottom button, here are their functions:

NEXT: The INC/ABS button now becomes the NEXT button. Press this button to move the arrow prompt to the different numerical points to be set.

UP: The inch/mm button now becomes the UP button. Press this button to change the numerical value where the arrow prompt is set.

SET: The CAL button now becomes the SET button. After adjusting numerical value using the UP and NEXT buttons, press the SET button to save your settings and return to “DRO Mode”.

Calibration Mode is useful to set the DRO to a specific bed height. After adjusting the bed to the desired height, look at the Inch/mm scale beside the bed. Transfer that height to the DRO in Calibration Mode.

You can also raise the bed to the highest level, engaging the minimum thickness depth stop (until the bed stops and the handwheel can’t be turned anymore). At that point, press and hold the SET button again and the DRO will read “0.125 1/8” (in inch mode), showing the minimum thickness of material allowed to be used on this machine. **NOTE:** The minimum thickness depth stop is located on the right underside of the head casting on the infeed side of the planer (see Figure 8-3). Clean any debris from the depth stop screw and receiving area before raising the bed.

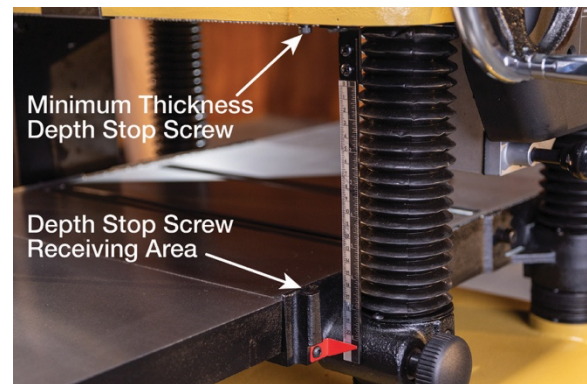

Figure 8-3: Minimum Thickness Depth Stop

9.0 Adjustments

⚠ WARNING

Always unplug the machine before making any adjustments (except feed rate). Accidental machine startup may cause serious injury from contact with the rotating cutterhead.

Tools required for adjustments:

- 3, 5, and 6mm hex wrenches
- 12, 14 and 19mm open-end wrenches
- Feeler gauges
- Straight edge
- Gauge block or dial gauge
- Cross-point (Phillips) screwdriver

9.1 Belt Tensioning

Refer to Figure 9-1.

Inspect the belt tension frequently during the first few uses of the planer. Belts often stretch during this trial period. If they require tightening, proceed as follows:

1. Remove the belt guards and the rear panel.
2. Loosen the bottom nut on the motor adjustment screw with a 19mm wrench.
3. Turn the top nut to lower the motor plate, thereby increasing the belt tension.
4. Proper tension is achieved when there is slight deflection in the belt midway between the pulleys, using moderate finger pressure.
5. Tighten the bottom nut.

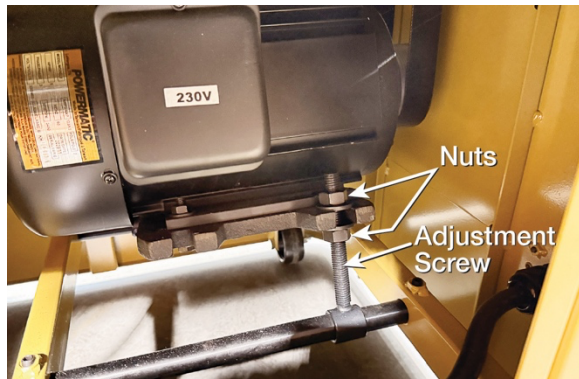

Figure 9-1: Belt Tensioning

9.2 Pulley Alignment

Refer to Figure 9-1 and 9-2.

The pulleys should be in line for proper belt operation.

1. Remove the belt guard covers, then place a straightedge against the faces of both pulleys (Figure 9-2).
2. If the straightedge does not lie flat on both pulley faces, open the rear panel, and loosen the four hex nuts on the motor plate (see Figure 9-1) with a 19mm wrench.
3. Nudge the motor left or right until the pulleys are in alignment.
4. Tighten hex nuts and replace covers.

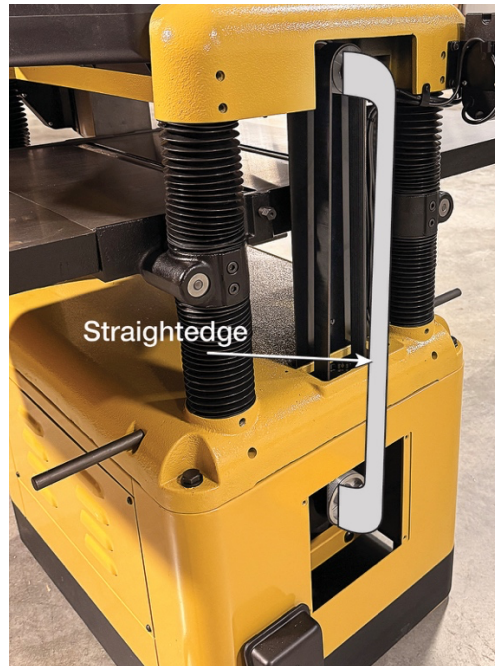

Figure 9-2: Pulley Alignment

9.3 Table Rollers

Refer to Figure 9-3, 9-4, and 9-5.

Your planer is supplied with two table rollers that rotate as the stock is fed into the machine, thereby reducing friction. It is not possible to give exact dimensions on the proper height setting of the table rollers because each type of wood behaves differently. However, when planing rough stock the table rollers should be set at a high position. When planing smooth stock, the rollers should be set at a low position.

NOTE: When raising the roller higher above the table, the range is from .003" to .006" (Figure 9-4).

The table rollers are factory set for average planing and are parallel to the table surface. If you desire to adjust the table rollers higher or lower, proceed as follows:

1. Disconnect machine from power source.
2. Lay a straight edge across both rollers.
3. On one side of the table, loosen the set screws (Figure 9-5) with a 3mm hex wrench, and turn the eccentric shafts to raise or lower the rollers.
4. When proper height is achieved, tighten set screws.
5. Adjust the rollers from the opposite side of the table in the same manner.

IMPORTANT: Be sure the heights of the front and rear rollers are the same. The table rollers must always be set parallel to the table.

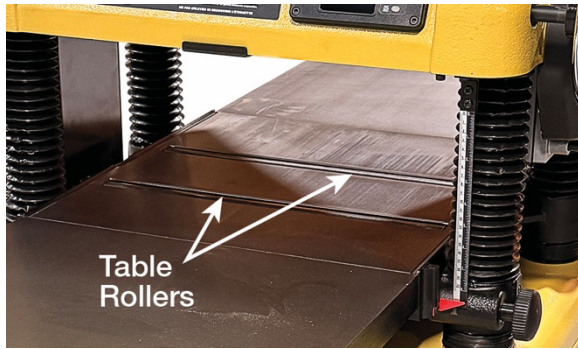

Figure 9-3

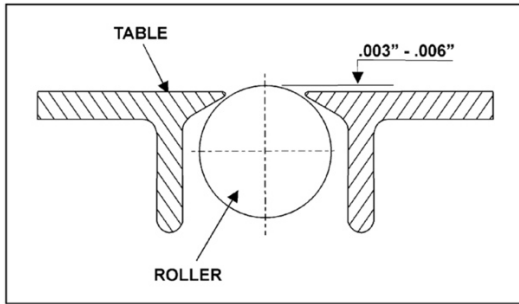

Figure 9-4

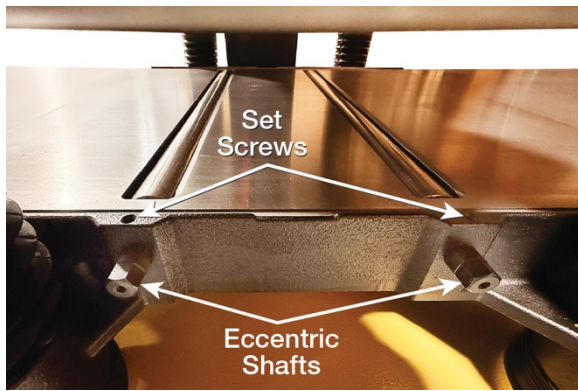

Figure 9-5

9.4 Cutterhead

Refer to Figure 9-6.

Although your planer was carefully adjusted at the factory, it should be checked before being put into operation. Any inaccuracies due to rough handling in transit can be corrected by following the directions in this manual.

To check the adjustments, you will need a knife-setting gauge (provided), feeler gauges, and either a dial gauge or a homemade hardwood gauge block. This gauge block can be made by following the dimensions shown in Figure 9-6. You will also need to remove the belt guard, so you can rotate the cutterhead using the pulley.

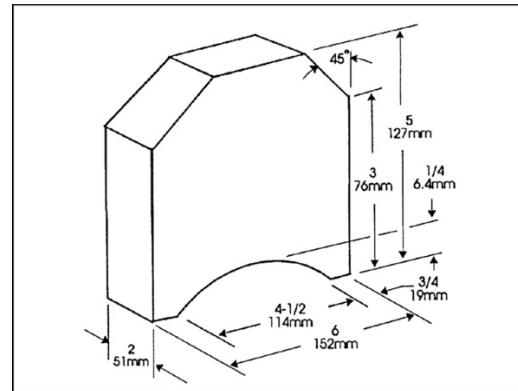

Figure 9-6

9.5 Adjusting or Replacing Rotating Knife Inserts

WARNING Always unplug the machine before making any adjustments. Accidental machine startup may cause serious injury from contact with the rotating cutterhead.

WARNING Never turn the cutterhead directly by hand. When changing the planer knives, only turn the cutterhead by the drive belt.

Refer to Figure 9-7.

To adjust knife inserts:

The knife inserts are four-sided. When dull, simply remove each insert, rotate it 90° to expose a fresh edge, and reinstall it.

Use the provided T25 screwdriver to remove the knife insert screw.

You should rotate all inserts at the same time to maintain consistent cutting. However, if one or more knife inserts develop a nick, rotate only the affected inserts.

Each knife insert has an etched reference mark to help you keep track of rotations.

IMPORTANT: When removing or rotating inserts, clean sawdust from the screw, the insert, and the cutterhead platform. Dust accumulation between these elements can prevent the insert from seating properly and may affect the quality of the cut.

WARNING Use care when handling knife inserts and cleaning around the cutterhead area – knife inserts are extremely sharp.

WARNING Make sure all knife insert screws are tightened securely. Loose inserts can be propelled at high speed from a rotating cutterhead, causing serious injury.

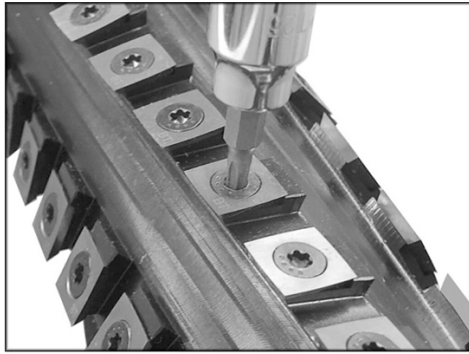

Figure 9-7

To install new knife inserts:

1. Before installing each screw, lightly coat the screw threads with machine oil and wipe off any excess.
2. Position knife insert and move it back and forth to verify there are no burrs or dirt.
3. Hold insert away from the back of the seat (pull slightly toward yourself if facing the cutting edge) and allow the screw to pull insert into position. NOTE: A slight offset between screw hole and hole in knife insert is normal. Do not position insert directly over screw hole, as it could ride up on the back of the seat and potentially cause cracking of the tip.
4. Securely tighten each screw that holds the knife inserts before operating the planer.

IMPORTANT: Maximum torque for tightening the screws is 45 to 55 inch-pounds (3.75 to 4.6 foot-pounds).

9.6 Work Table Parallel to Cutterhead

The work table is set parallel to the cutterhead at the factory and no further adjustment should be necessary. If your machine is planing a taper, first check to see if the knives are set properly in the cutterhead. Then check whether the work table is set parallel to the cutterhead. Proceed as follows:

1. Disconnect machine from power source.
2. Place the gauge block (Figure 9-8) on the work table directly under the edge of a knife or knife insert as shown. Make slight contact with the knife edge by gently raising the table.
3. Move the gauge block to the opposite end of the work table. The distance from the work table to the edge of the knife should be the same on both ends of the knife.

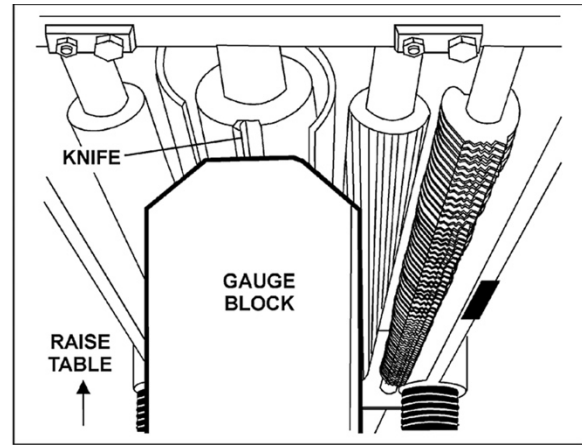

Figure 9-8

If the work table is not parallel to the cutterhead, perform the adjustment procedure as follows:

Refer to Figure 9-9.

1. Disconnect machine from power source.
2. Remove bolts holding the planer to the stand. Tilt planer on its side to expose underside of base.
3. Remove bolt (A) and loosen bolt (B) which will allow you to move the idler sprocket assembly (C) far enough to release tension on the chain.
4. Remove the chain from the sprocket at the corner of the base you need to adjust.
5. Turn the sprocket by hand to bring that corner into adjustment with the other three corners. NOTE: Turning sprocket clockwise will increase the distance between the working table and the head casting; counterclockwise will decrease the distance. This adjustment is very sensitive, and it should not be necessary to turn the sprocket more than one or two teeth.
6. When adjustments are correct, replace chain around corner sprocket, slide idler sprocket (C) back to re-tension chain, tighten bolt (B) and insert and tighten bolt (A).

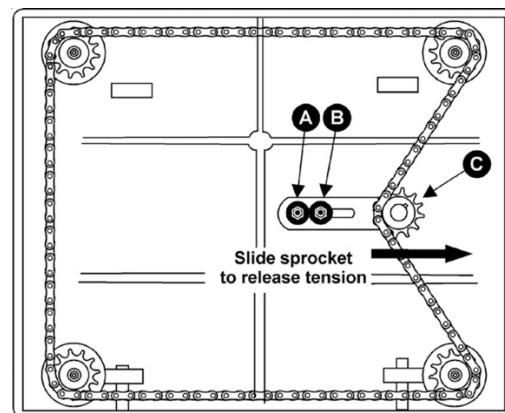

Figure 9-9

9.7 Transmitting Rollers, Chipbreaker, and Pressure Bar

Parts Identification (see Figure 9-10):

- A. Anti-Kickback Fingers
- B. Infeed Roller
- C. Chipbreaker
- D. Cutterhead
- E. Pressure Bar
- F. Outfeed Roller

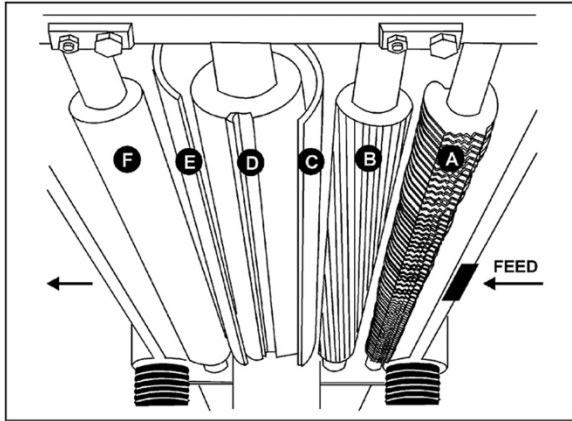

Figure 9-10

9.7.1 Anti-Kickback Fingers

The anti-kickback fingers (A, Figure 9-10) are an important safety feature. They help prevent kickback of stock. They operate by gravity and should be inspected frequently to ensure they are free of gum and pitch, so they move independently and operate correctly.

9.7.2 Infeed and Outfeed Roller Spring Tension

The infeed roller (B, Figure 9-10) and outfeed roller (F, Figure 9-10) are those parts of your planer that feed the stock while it is being planed. The infeed roller and the outfeed roller are under spring tension and this tension must be sufficient to feed the stock uniformly through the planer without slipping but should not be so tight that it causes damage to the board. The tension should be equal at both ends of each roller. Roller tension screws are located on top of the machine (Figure 9-11). NOTE: Contact Powermatic Technical Service before attempting any adjustments to spring tension.

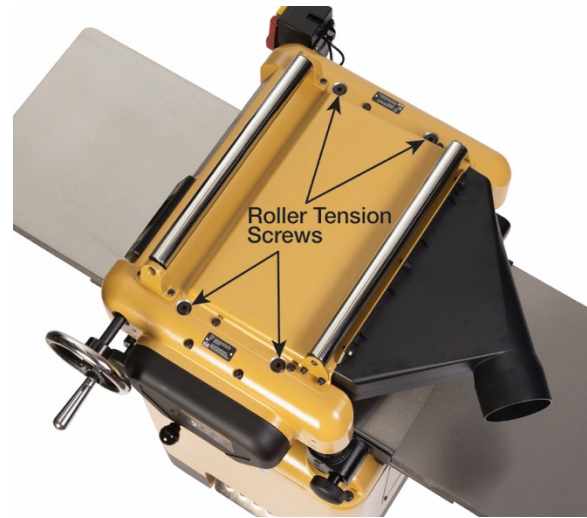

Figure 9-11

9.7.3 Height of Infeed Roller, Chipbreaker, Pressure Bar, and Outfeed Roller

The infeed roller, chipbreaker, pressure bar, and outfeed roller are adjusted at the factory. The height relationship between these items and the cutterhead is crucial for accurate and safe planing. The infeed roller should each be set at 0.024" (0.6mm) below the arc of the knives. The outfeed roller should each be set at 0.028" (0.7mm) below the arc of the knives. The pressure bar is set 0.02" (0.5mm) above the arc of the knives. The chipbreaker is set even with the knife arc. See Figure 9-12.

If any adjustments are necessary for the infeed roller, chipbreaker, or outfeed roller, they should be done carefully. Use the following steps as an example of procedure.

NOTE: This procedure uses a homemade gauge block (Figure 9-6) and feeler gauges, which should be sufficient for most planer operations. If extra-precise measurements are desired, use a dial indicator.

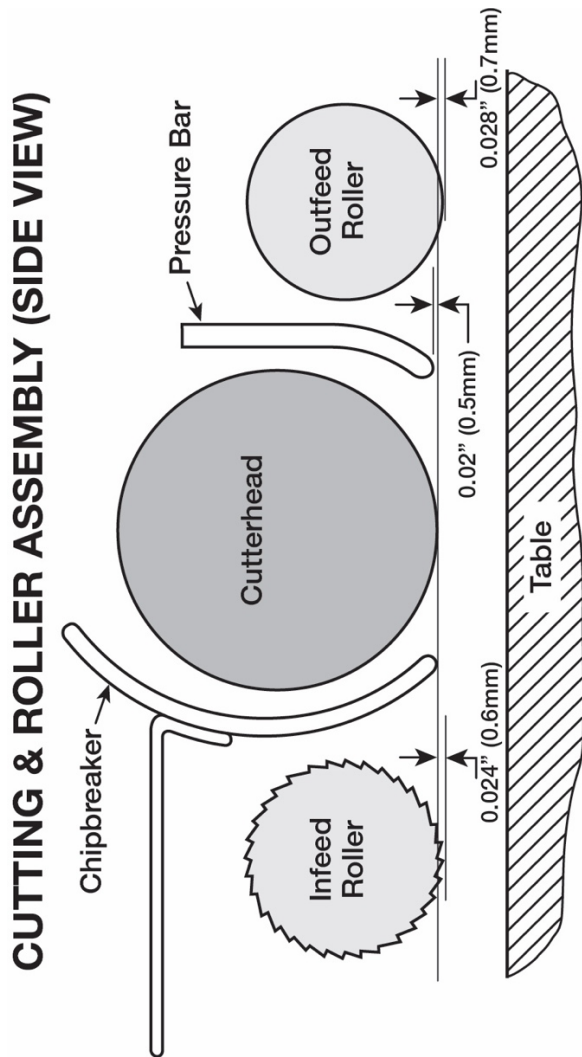

Figure 9-12

Outfeed Roller Height Adjustment

Refer to Figures 9-13 and 9-14.

1. Disconnect machine from power source.
2. Make sure the knife inserts are set properly. See *Section 9.5, Adjusting or Replacing Rotating Knife Inserts*.
3. Place the gauge block (J) on the table directly beneath the cutterhead (D).
4. Using a 0.028" (0.7mm) feeler gauge (K) placed on top of the gauge block, raise the worktable until the knife just touches the feeler gauge when the knife is at its lowest point. Do not move the worktable any further until the outfeed roller is adjusted.
5. Remove the feeler gauge and move the gauge block (J) under one end of the outfeed roller. The bottom of the outfeed roller should just touch the top of the gauge block. If an adjustment to the outfeed roller is necessary, loosen the lock nut (L) and turn screw (M) until the outfeed roller just touches the gauge block. Then tighten lock nut (L).

6. Check and adjust the opposite end of the outfeed roller in the same manner.

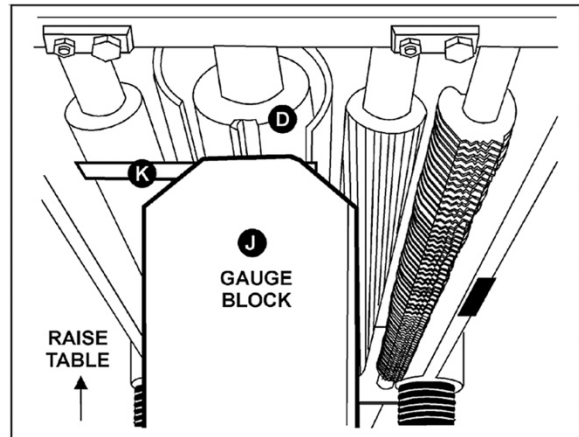

Figure 9-13

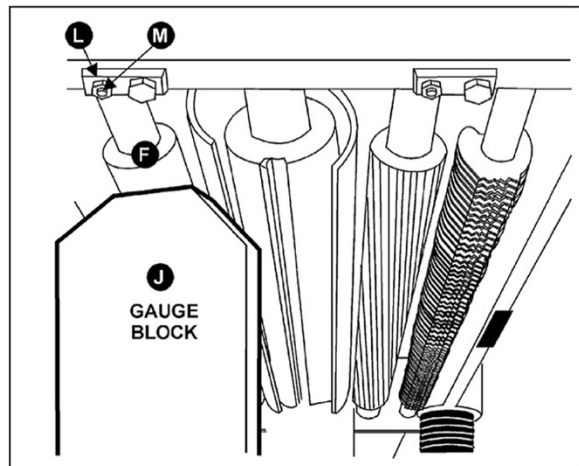

Figure 9-14

Infeed Roller Height Adjustment

Use the exact same procedure for checking the infeed roller (B) as you did for the outfeed roller (F), using a 0.024" (0.6mm) feeler gauge atop the gauge block. If adjustment is necessary, use the lock nut and screw on each end of the infeed roller.

Chipbreaker Height Adjustment

The chipbreaker (C) breaks off the larger chips before the stock reaches the cutterhead. Use the gauge block to set the chipbreaker even with the knives' arc, following the same procedure as above. If adjustment is needed:

1. Remove top cover.
2. Loosen the lock nuts (A, Figure 9-15) at both ends of the chipbreaker and turn the set screws to raise or lower the chipbreaker as needed. The set screws should be turned the same amount.
3. When the chipbreaker contacts the gauge block, tighten both lock nuts (A, Figure 9-15).

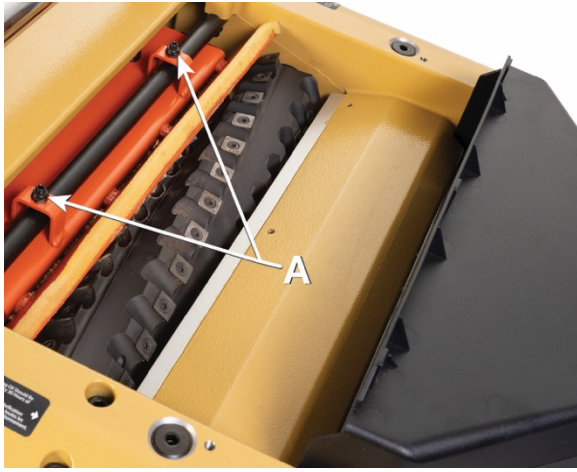

Figure 9-15

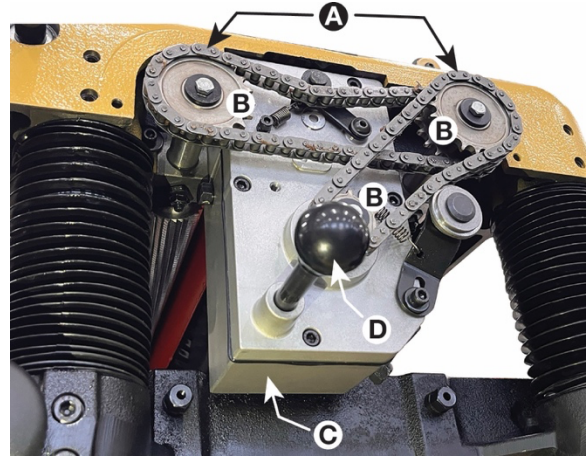

Figure 9-16

9.8 Feed Speed Control

CAUTION Do not attempt to change feed speed while stock is passing through the machine. Damage to the gearbox may result.

Refer to Figures 9-16 through 9-19.

Your machine is equipped with a spiral, serrated infeed roller and a solid steel rubber-coated outfeed roller. When the feed rollers are engaged, they turn to feed the stock. The feed rollers slow automatically when the machine is under heavy load for best planing in all conditions. The feed rollers are driven by chains (A, Figure 9-16) and sprockets (B, Figure 9-16), which receive power directly from the cutterhead via the oil-bath gearbox (C, Figure 9-16). The drive chain does not need tensioning, as a tension device maintains proper tension at all times.

To gain access to the chain and sprockets:

1. Remove the socket head cap screw from the center of the cover (see Figure 9-17).
2. Pull the cover off the machine.

WARNING Always reinstall the cover over the chain and sprockets before operating the planer.

The gearbox has two feed speeds. These are set by pulling out or pushing in the feed rate shift lever (D, Figure 9-16). Always change feed speed while the machine is running. A label showing the lever positions is affixed just above the lever. It is also shown in Figure 9-19.



Figure 9-17



Figure 9-18

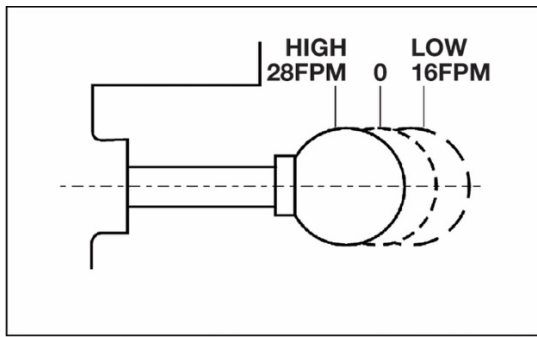

Figure 9-19

9.9 Depth of Cut Adjustment

Refer to Figure 9-20.

The depth of cut is measured using either the digital readout control (DRO) or the manual depth scale. The maximum workpiece thickness is 8 inches. The minimum workpiece thickness is 1/8 inch.

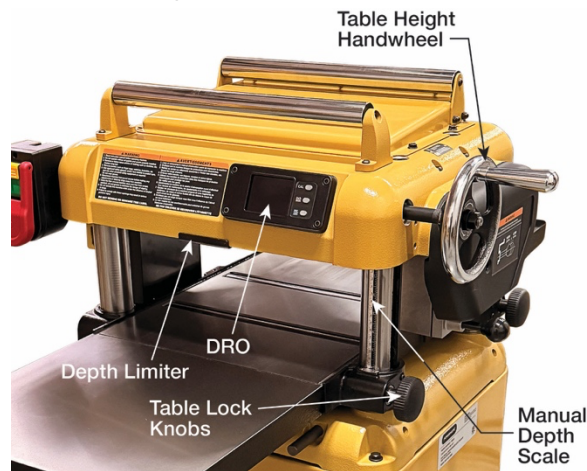

Figure 9-20

The distance of upward or downward movement is controlled by the table height handwheel. Before moving the table up or down, loosen the table lock knobs. After obtaining proper table position, tighten the table lock knobs.

The maximum depth of cut is 3/32". A depth limiter on the front of the head casting limits the workpiece thickness on full-width planing to 1/8".

The DRO should be calibrated before operating the planer. See, Section 8.0, *Digital Readout Control*, for instructions.

10.0 Operation

Thickness planing is the process of sizing lumber to a desired thickness while creating a level surface parallel to the opposite side of the board.

Note: The cutterhead may throw off a slight spray of lubricant when the machine is first turned on. Allow it to run for a few moments, then shut it off and wipe any oil off the tables before proceeding.

WARNING To avoid the risk of injury from kickbacks, do not stand directly in line with the front or rear of the planer.

10.1 General Recommendations

1. Many factors determine the appropriate depth of cut, such as wood width, density, grain structure, and moisture content. For best results, use shallow cuts and multiple passes. Excessive depth of cut can place additional strain upon the motor.
2. Use shallower cuts on wider workpieces.
3. A thickness planer works best when the lumber has at least one flat surface. Use a jointer to create a flat surface. If this is not possible, make several passes of the same surface through the planer until it is flat. Then flip the material over to plane the opposite surface.
4. Plane alternate sides until desired thickness is obtained. When half of the total cut has been taken from each side, the board will have a uniform moisture content and additional drying will not cause it to warp.
5. Make a test cut on scrap wood to verify thickness; check its accuracy before working on the finished product.
6. Avoid knots. Heavily cross-grained wood makes knots hard. Knots can come loose and jam the knives.
7. Do not plane dirty boards; dirt and small stones are abrasive and will wear out the knife inserts.
8. Do not plane boards less than 8 inches long. When planing short boards, butt them end-to-end to avoid kickback and reduce snipe.
9. For optimal planing performance, the depth of cut should be less than 1/16 inch.
10. Recommended *maximum* depth of cut:
 - Hard/Softwood up to 6" wide.....1/8"
 - Hard/Softwood 6" to 20" wide.....1/16"
11. Before starting work, check to see that the following are in proper working order:
 - Power cable and plug
 - ON/OFF switch
 - Cutterhead cover in place
 - Push stick
12. Assume proper operating position when planing:
 - Stand to the side of the infeed table.
 - When working with two people, the second person must stay a sufficient distance from the planing machine and stand to the side of the infeed or outfeed table, respectively.
13. If the type of work requires, use the following:

- Workpiece support (e.g. roller support) – to keep the machine from tipping over when working long workpieces.
- Push stick (feeding aid) – for short workpieces.
- Dust collector
- Sliding wax – to enhance the gliding of the workpieces through the machine, apply a light coat of sliding wax to the surfaces of the infeed and outfeed tables.

14. Avoid typical operator mistakes:

- Do not exceed the specified workpiece dimensions.
- To reduce the risk of kickback, do not force the workpiece.

10.2 Basic Operating Procedure

1. Turn table height handwheel to desired setting. Use DRO or manual depth scale to determine desired position.
2. Start planer by pressing green ON switch.
3. Turn on dust collection system.
4. Place material flat-side down on infeed table and slide it straight into machine until it is engaged by infeed roller. Do not push or pull on the workpiece as it is being planed.
5. Move to rear of planer, out of the line of feed, and grasp the workpiece after it exits the machine.
6. Lower cutterhead to desired cut depth for next pass. Flip the material over and re-feed it through machine.
7. Repeat procedure as necessary. If a jam occurs, turn planer OFF and raise head to withdraw the workpiece.

10.3 ON/OFF Switch

Refer to Figure 10-1.

- ON Switch (A)
- Lockout Key (B)
- Stop Paddle (C)

Press the ON switch to start the planer. Press the stop paddle to turn planer off. Remove the lockout key to prevent unauthorized operation or accidental starting.

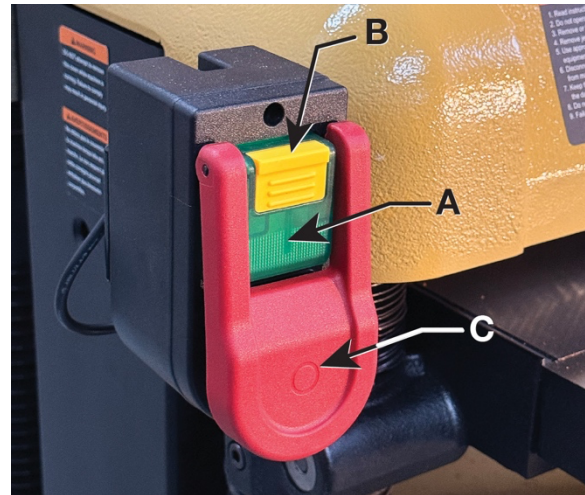

Figure 10-1

10.4 Before Planing a Workpiece

Test the Machine When Idling:

1. Make sure there are no obstructions preventing the cutterhead from rotating freely.
2. Move cutterhead to desired planing thickness.
3. Start the motor by pressing the green ON switch (A, Figure 10-1).
4. Once the machine has reached full speed, pay attention to noise and vibrations.

CAUTION If noise and/or vibration appear unusually high, turn OFF the machine immediately and unplug it. Check machine for parts that may have worked loose. Tighten any loose parts as needed.

10.5 Planing Workpieces

The thickness planer can remove up to 3/32" (2.37mm) of a full-width workpiece in a single pass.

However, this maximum depth of cut may be used only:

- With very sharp planer knife inserts
- When planing soft wood

Otherwise, there is a risk of overloading the machine.

For best results, you should make several passes at a shallower depth of cut to achieve the desired workpiece thickness.

Note: The ideal depth of cut depends on several factors, such as the type of wood, the workpiece width, and the wood's dryness.

If you are planing mainly very wide (20-inch (508mm) workpieces, the motor is subjected to heavy loads. Plane narrow workpieces in between or take a break to let the motor rest.

Workpiece Dimensions

- Do not use workpieces shorter than 8 inches. (203mm). With shorter workpieces, there is a risk of kickback.
 - Do not use workpieces that are thinner than 1/8 in. (3.18 mm). The cutterhead cannot be set lower.
 - Use only workpieces wider than 3/4 inch (19 mm).
 - Use additional workpiece supports for workpieces longer than 59 in. (1500 mm).
 - Never thickness several workpieces side-by-side at the same time. Risk of personal injury if individual pieces are uncontrolled and caught by the cutterhead.
1. Set the planing thickness using the table height handwheel. The planing thickness is indicated by the manual depth scale or the DRO. See Figure 10-2.
 2. Start the motor by pressing the green ON switch (A, Figure 10-1).

⚠ WARNING To avoid the risk of injury from kickbacks, do not stand directly in line with the front or rear of the planer.

⚠ WARNING Adjust the planing thickness only when the cutterhead is stopped.

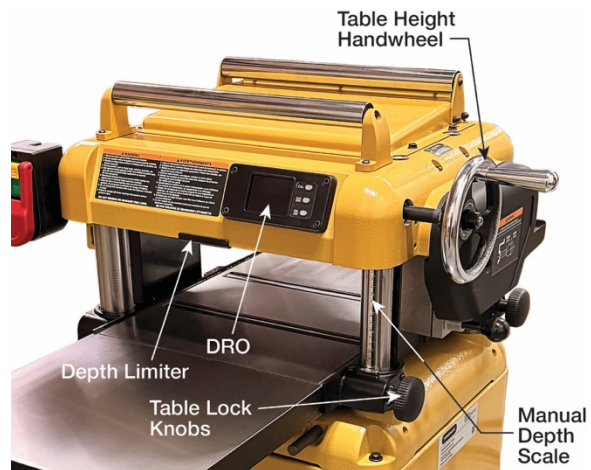

Figure 10-2

⚠ WARNING Never reach into the machine with your hands when guiding the workpiece.

⚠ WARNING Never force the workpiece into the machine by pushing or shoving. The machine will automatically draw the workpiece in using the infeed roller.

3. Slide workpiece slowly over the infeed table. It will then be automatically fed through the planer.

4. Release workpiece when the infeed roller starts automatically moving it through the planer.
5. Remove workpiece from outfeed side of planer after the outfeed rollers stop automatically moving it. For longer workpieces, be sure to support them as they exit the planer and the outfeed table.
6. Switch machine off if no further planing is to be done immediately afterwards.

10.6 Planing Warped Wood

⚠ WARNING Do not attempt to plane a board that is warped along its length. A warped board can jam itself against the cutterhead knives, resulting in kickback and/or damage to the planer.

Note that if a significantly cupped board is fed into the planer, the feed rollers will press it flat for the pass, but the wood will spring back into cupped form when it has cleared the rollers. For best results, one side of the material should be run through a jointer to achieve a flat surface for planing. However, if a board is only moderately cupped, you may attempt to plane it.

If the board is narrow enough, consider using a table saw or band saw to rip the top of the warp before planing. If this is not practical, feed the board into the planer concave-side down, and plane the top until it presents a flat surface.

Turn the board over and plane the bottom edges until they are flush with the middle. After planing the board, use a table saw or band saw to square the board's edges with the top and bottom surfaces.

Cupping can often be diminished by ripping the board into narrower pieces on a table saw or band saw. See Figure 10-3.

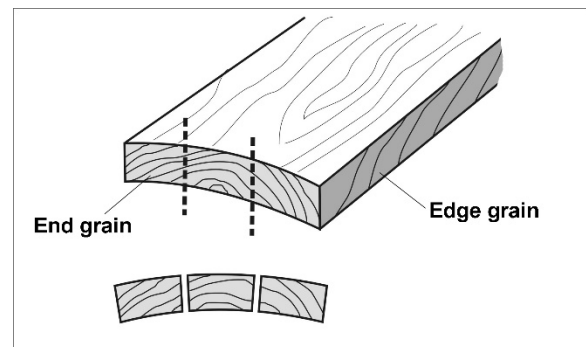

Figure 10-3: Cupping Reduction

10.7 Grain Direction

Always feed the board so the knives are cutting in the same direction as the wood grain, as shown in Figure 10-4. If you cut against the grain, the wood can “chip out” leaving an undesirable finish. See Figure 10-5.

TIP: On rough lumber, you may need to rip one edge on a table saw or band saw to more easily observe a board's grain direction. Also, the grain in some wood species may change direction in the middle of the board – if possible, cut the board in the middle so the grain direction is consistent on both pieces. Otherwise, use personal judgment as to which direction is more favorable and safer for feeding.

Edge grain (see Figure 10-3) may be planed if the stock is wide enough to rest firmly upon the table.

Do not attempt to plane end-grain (see Figure 10-3) as this can result in splintering of the stock and potential kickback.

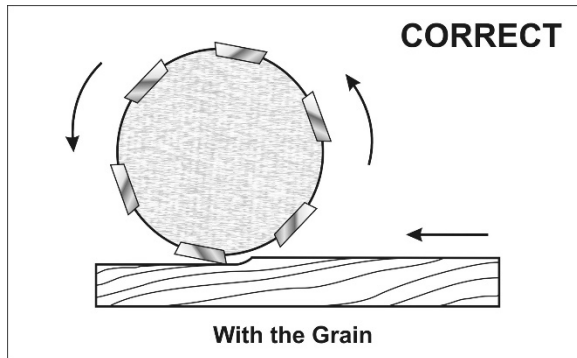

Figure 10-4

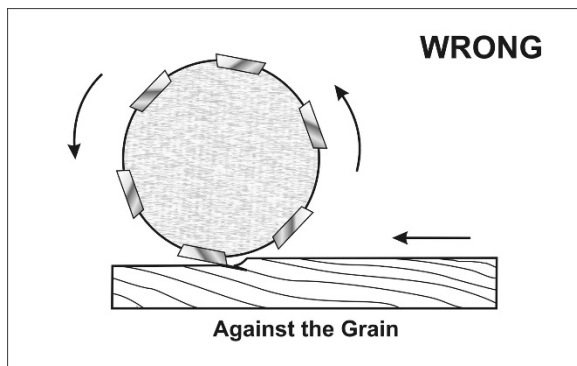

Figure 10-5

10.8 Knots and Trouble Spots

Wood with knots, “wild” grain, or extensive figuring is always difficult to surface and requires extra care. Check that any knots are solid. Do not plane stock with loose knots. Take light cuts. Be especially cautious of kickbacks and stop cutting immediately if the board will not feed smoothly.

10.9 Snipe

Snipe refers to a depression at either end of the board caused by an uneven force on the cutterhead when the work is entering or leaving the planer. Snipe may occur when the board is not supported properly or when only one feed roller is in contact with the board at the beginning or end of the cut.

If the snipe is deep, be more careful how the board is supported. Keep it parallel to and flat on the table at all times. Use an extra support, such as a roller

stand, at both the infeed and outfeed ends of the planer.

Other methods to prevent snipe are reducing the depth of cut, and feeding additional boards butted closely to leading and trailing ends of the workpiece.

If snipe cannot be avoided, cut the material longer than needed and trim the ends after planing.

10.10 Ridges

Damaged knife inserts can leave ridges along the length of a board.

Always inspect each board carefully before attempting to plane it. Do not attempt to plane second-hand lumber with nails below the surface, painted wood, plywood, hardboard, wood with a glue bead, or any material other than solid wood.

⚠ WARNING

Do not attempt to plane second-hand lumber, painted or varnished wood, plywood, or particle board. These materials can damage planer knives. Failure to comply may cause serious injury.

10.11 Planing Rough Lumber

⚠ CAUTION

Make sure wood is properly dried before planing. Wet or “green” lumber may clog the machine and lead to damage.

Air-dried wood should stand for at least a year per inch of thickness of the rough-cut stock. The moisture content of air-dried wood should be about 12% to 15%. Kiln-dried woods should have a moisture content of approximately 10%. Wood used for fine furniture should have a moisture content of 7% to 8%.

Joint one edge of the rough-cut lumber before planing. This will help you determine the direction of grain travel. Feed the board into the planer so the knives cut with the grain, see Figure 10-4.

Measure the rough lumber at several locations to find the thickest part. As wood dries, its dimensions vary, including its thickness. Set the planer to take a very shallow cut on the highest, thickest part of the board. Continue to take very shallow cuts until you can determine whether there are any knots or unusual grain patterns.

After completing one side, inspect the opposite side for irregularities, then process it using the same procedure as for the first side.

10.12 Planing Glued-Up Boards

⚠ WARNING Glued-up stock must dry at least 24 hours before being planed. Failure to comply may cause the stock to separate in the planer, leading to kickback and serious injury.

This planer is designed for planing solid wood. Other material, including glue, will dull or damage the knives. However, when you need to “true-up” glued-together stock, follow these suggestions.

As you glue the stock, scrub off any excess glue from the surface with a wet rag. This prevents glue beads from forming on the wood surface. Allow the glue to dry at least 24 hours. Check the surface for any glue that you missed and remove with a scraper, chisel, or sander.

Set the cutterhead for a shallow depth of cut. When you are finished planing the glued-up board, unplug the planer and check planer knives for built-up pitch or other signs of wear.

11.0 Maintenance

⚠ WARNING Disconnect power to planer (unplug) before performing any maintenance. Failure to comply may result in serious personal injury.

⚠ WARNING Burning hazard! Right after planing the planer knives may be hot – let the machine cool down before servicing.

11.1 Inspection and General Cleaning

Periodic inspections are required to ensure that the machine is properly adjusted, that all screws are tight, that belts are in good condition, that no dust has accumulated in the electrical enclosures, and that there are no worn or loose electrical connections.

Buildup of sawdust and other debris can cause your machine to plane inaccurately. Periodic cleaning is not only recommended but mandatory for accurate planing.

Close-fitting parts, such as the cutterhead slot and gibs, should be cleaned with a cloth or brush and non-flammable solvent, and freed from clinging foreign matter.

Remove resin and other buildup from the feed rollers and table using a soft rag and a non-flammable solvent.

Periodically check all chains for proper tension and adjust as needed.

The table should be kept clean and free of rust. Some users prefer a paste wax on exposed steel and cast iron surfaces. The wax provides a layer of protection and reduces friction between the lumber

and the table, making cuts faster and smoother. Avoid any wax that contains silicone or other synthetic ingredients. These materials can find their way into lumber and can make staining and finishing difficult.

Another option is to apply talcum powder with a blackboard eraser, rubbed in vigorously once a week; this will fill casting pores and form a moisture barrier. This method provides a slick tabletop that allows rust rings to be easily wiped from the surface. Also important is that talcum powder will not stain wood or mar finishes, as some wax pickup can.

11.2 Lubrication

The bearings on the cutterhead are factory lubricated and sealed for life – no lubrication is required.

Gearbox Lubricant

The lubricant in the gearbox must be replaced every 2,500 hours. A multi-purpose gearbox lubricant will be suitable.

To replace the lubricant:

Refer to Figure 11-1.

1. Remove the drain plug (A) with a 14mm wrench and remove filler cap (B). Drain dirty oil thoroughly.
2. Insert and tighten the drain plug (A).
3. Fill with clean lubricant through filler hole (B).
4. Install and tighten filler cap (B).

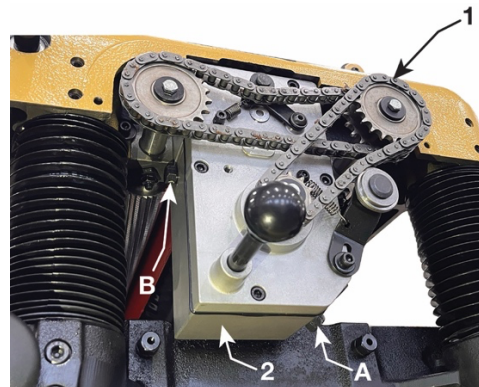

Figure 11-1

Lubrication Chart

Refer to Figures 11-2 through 11-4

No.	Position	Interval	Type
1	Drive Chain	Frequently	Grease
2	Gearbox	Every 2500 hrs.	Standard gear oil, 70-90 wt.
3	Return Rollers	Frequently	SAE 30
4	Worm Gear	Frequently	Grease
5	Lead Screw	Frequently	Grease
6	Column	Frequently	SAE 30
7	Table Chain	Frequently	Grease
8	Feed Rollers	Frequently	SAE 30



Figure 11-3

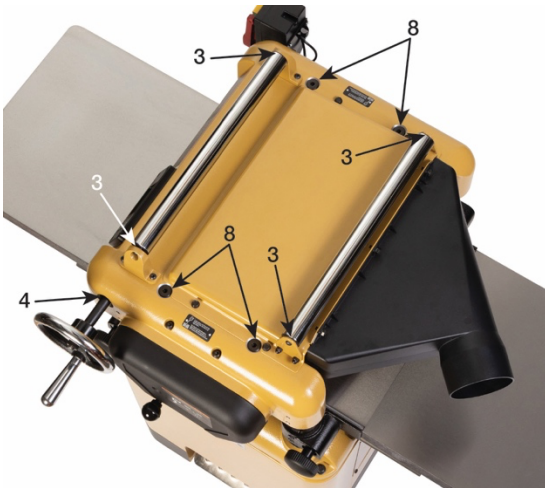

Figure 11-2

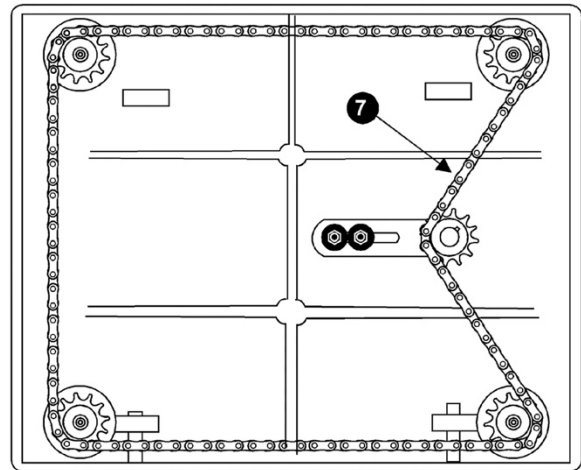

Figure 11-4

11.0 Troubleshooting

Operating Problems

Trouble	Probable Cause	Remedy
Snipe. <i>(NOTE: Snipe cannot be eliminated but can be so minimized as to be negligible.)</i>	Table rollers not set properly.	Adjust rollers to proper height.
	Inadequate support of long boards.	Support long boards with extension rollers.
	Uneven feed roller pressure front to back.	Adjust feed roller pressure.
	Dull knife inserts.	Rotate or replace knife inserts.
	Lumber not butted properly.	Butt end to end each piece of stock as they pass through.
Fuzzy grain.	Planing wood with high moisture content.	Remove moisture by drying or use different stock.
	Dull knife inserts.	Rotate or replace knife inserts.
Torn grain.	Too heavy a cut.	Adjust proper depth of cut.
	Knife inserts cutting against the grain.	Cut along the grain where possible.
	Dull knife inserts.	Rotate or replace knife inserts.
Rough/raised grain.	Dull knife inserts.	Rotate or replace knife inserts.
	Too heavy a cut.	Adjust proper depth of cut.
	Planing wood with high moisture content.	Remove moisture by drying or use different stock.
Rounded, glossy surface.	Dull knife inserts.	Rotate or replace knife inserts.
	Feed rate too slow.	Increase feed rate.
	Cutting depth too shallow.	Increase cutting depth.
Poor feeding of lumber.	Inadequate feed roller pressure.	Adjust feed roller tension. If proper tension cannot be achieved, replace feed rollers.
	Planer table rough or dirty.	Clean pitch and residue from table and apply paste wax.
	Belt slipping on pulleys.	Tighten belt.
	Surface of feed rollers too smooth.	Lightly roughen the feed roller surface with sandpaper.

Mechanical and Electrical Problems

Trouble	Probable Cause	Remedy
Uneven depth of cut side to side.	Table not parallel to cutterhead.	Adjust table/cutterhead parallelism.
Board thickness does not match depth of cut scale.	Depth of cut scale is incorrect.	Adjust depth of cut scale.
Chain is jumping.	Inadequate tension.	Adjust chain tension.
	Sprockets misaligned.	Align sprockets.
	Sprockets are worn.	Replace sprockets.
Machine will not start/restart or repeatedly trips circuit breaker or blows fuses.	No incoming power.	Verify power connections to planer.
	Overload automatic reset has not reset.	When planer overloads on the circuit breaker built into the motor starter, it takes time for the machine to cool down before restart. Allow unit to adequately cool before attempting restart. If problem persists, check amp setting on the motor starter inside the electrical box.
	Planer frequently trips.	One cause of overloading trips which is not electrical in nature is too heavy a cut. The solution is to take a lighter cut. If too deep a cut is not the problem, then check the amp setting on the overload relay. Match the full load amps on the motor as noted on the motor plate. If amp setting is correct, then there is probably a loose electrical lead. Check amp setting on motor starter.
	Building circuit breaker trips or fuse blows.	Verify that planer is on a circuit of correct size. If circuit size is correct, there is probably a loose electrical lead. Check amp setting on motor starter.
	Loose electrical connections.	Go through all the electrical connections on the planer including motor connections, verifying the tightness of each. Look for any signs of electrical arcing which is a sure indicator of loose connections or circuit overload.

Trouble	Probable Cause	Remedy
Machine will not start/restart or repeatedly trips circuit breaker or blows fuses. (cont.)	Motor starter failure.	<p>Examine motor starter for burned or failed components. If damage is found, replace motor starter. If motor starter looks okay but is still suspect, you have two options: have a qualified electrician test the motor starter for function or purchase a new starter and establish if that was the problem on changeout.</p> <p>If you have access to a voltmeter, you can separate a starter failure from a motor failure by first, verifying incoming voltage at 230+/-10 and second, checking the voltage between starter and motor at 230+/-10.</p> <p>If incoming voltage is incorrect, you have a power supply problem.</p> <p>If voltage between starter and motor is incorrect, you have a starter problem.</p> <p>If voltage between starter and motor is correct, you have a motor problem.</p>
	Motor failure.	If electric motor is suspect, you have two options: Have a qualified electrician test the motor for function or remove the motor and take it to a quality electric motor repair shop and have it tested.
	Miswiring of the unit.	Check to confirm all electrical connections are correct and properly tight. Make any needed corrections.
	On/off switch failure.	If the on/off switch is suspect, you have two options: Have a qualified electrician test the switch for function or purchase a new on/off switch and establish if that was the problem on changeout.



* Some corrections may require a qualified electrician.

12.0 Replacement Parts

Replacement parts are listed on the following pages. To order parts or reach our service department, call 1-800-274-6848 Monday through Friday, 8:00 a.m. to 5:00 p.m. CST. Having the Model Number and Serial Number of your machine available when you call will allow us to serve you quickly and accurately.

Non-proprietary parts, such as fasteners, can be found at local hardware stores or may be ordered from JET. Some parts are shown for reference only and may not be available individually.

12.1.1 Table Assembly – Exploded View

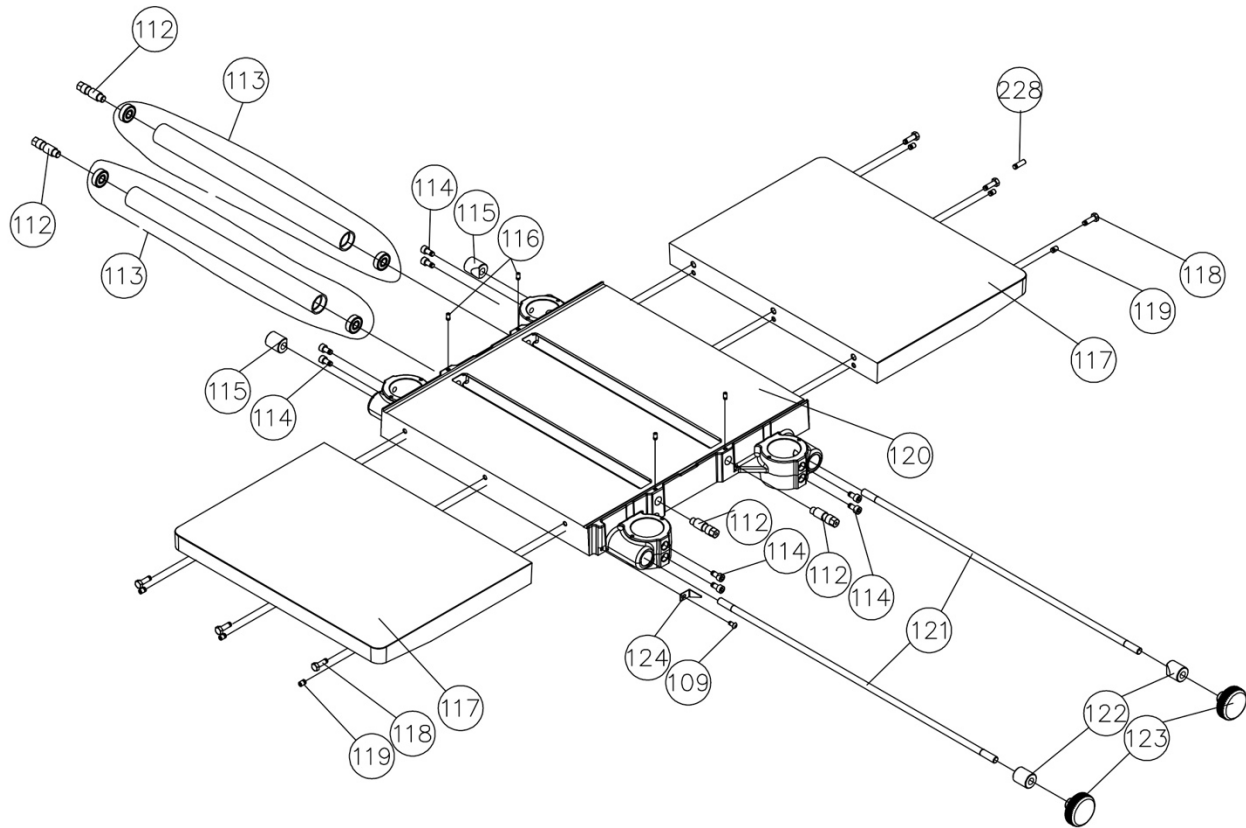

12.1.2 Table Assembly – Parts List

Index No.	Part No.	Description	Size	Qty
109	**	Socket Head Button Screw	M6 x 1.0P x 12	1
112	**	Eccentric Shaft		4
113	PM1-543	Table Roller Assembly		2
114	**	Socket Head Cap Screw	M8 x 1.25P x 16	8
115	**	Left Table Lock Block		2
116	**	Socket Head Set Screw	M6 x 1.0P x 12	4
117	PM1-544	Extension Table		2
118	**	Hex Head Screw	M8 x 1.25P x 25	6
119	**	Socket Head Set Screw	M8 x 1.25P x 12	14
120	**	Main Table		1
121	**	Table Lock Shaft		2
122	PM1-522	Right Table Lock Block		2
123	PM1-545	Table Lock Knob		2
124	**	Pointer		1

** These parts are shown for reference only and are not available for order individually. Non-proprietary parts, such as fasteners, can usually be found at local hardware stores.

12.2.1 Cutterhead Assembly – Exploded View

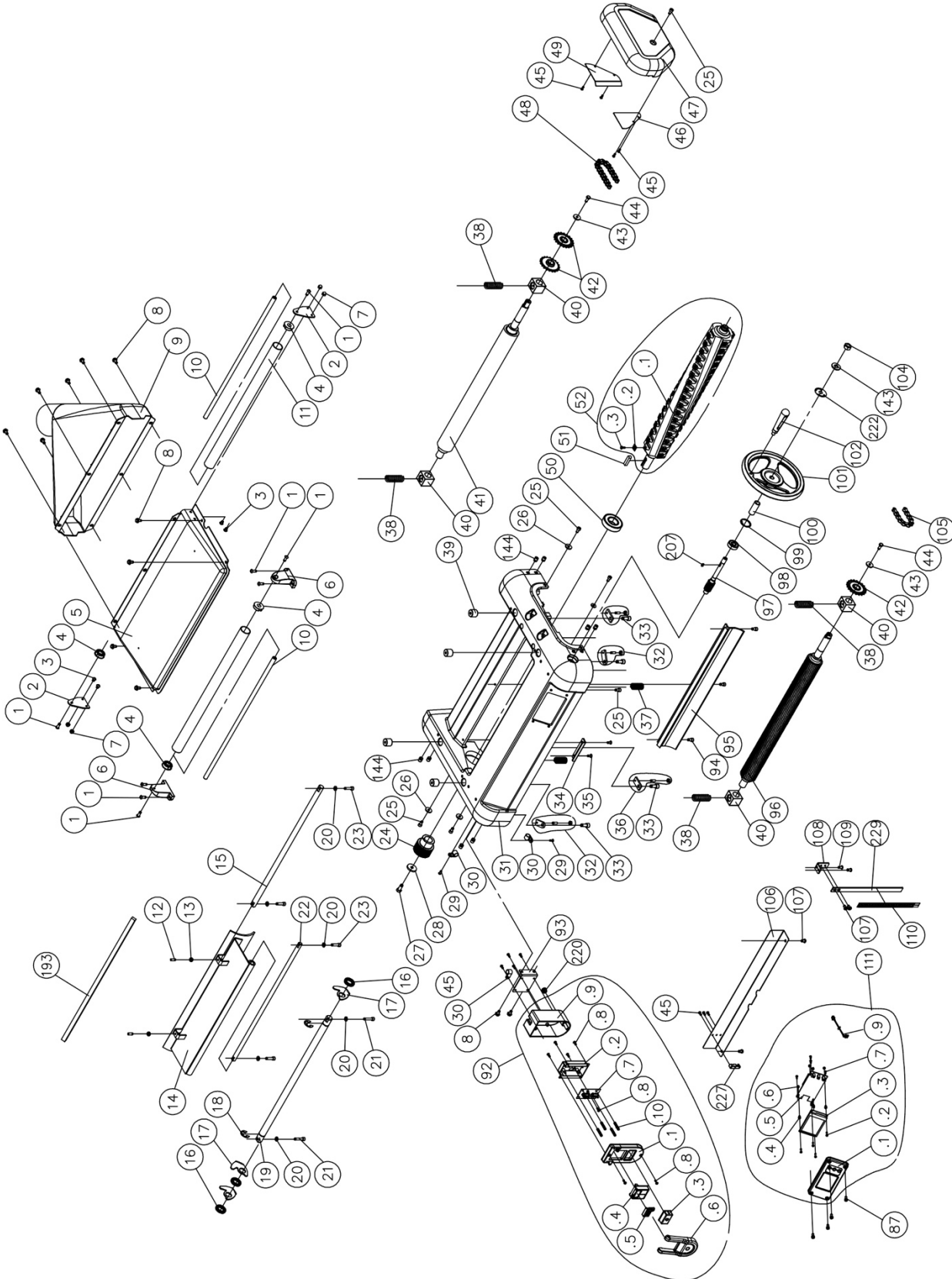

12.2.2 Cutterhead Assembly – Parts List

Index No.	Part No.	Description	Size	Qty
1	**	Socket Head Button Screw	M6 x 1.0P x 16	8
2	PM1-493	Return Roller Rear Bracket		2
3	**	Socket Head Button Screw	M6 x 1.0P x 8	4
4	**	Bushing		4
5	PM1-523	Top Cover		1
6	PM1-495	Return Roller Front Bracket		2
7	**	Cap Nut	M6 x 1.0P	4
8	**	Hex Head Cap Screw w/Flat Washer	M6 x 1.0P x 12	12
9	PM1-524	Dust Chute		1
10	**	Return Roller Shaft		2
11	PM1-525	Return Roller		2
12	**	Socket Head Set Screw	M6 x 1.0P x 16	3
13	**	Nylon Lock Hex Nut	M6 x 1.0P	2
14	**	Chip Breaker		1
15	**	Chip Breaker Support Shaft		1
16	**	Spacer		53
17	**	Anti-kickback Pawl		52
18	**	Retaining Ring	ETW-15	2
19	**	Stop Shaft		1
20	**	Flat Washer	6.3 x 13 x 2.0T	10
21	**	Socket Head Cap Screw w/thread locker	M6 x 1.0P x 30	2
22	**	Chip Breaker Pivot Shaft		1
23	**	Socket Head Cap Screw w/thread locker	M6 x 1.0P x 25	4
24	**	Cutter Head Pulley		1
25	**	Socket Head Cap Screw	M6 x 1.0P x 12	5
26	**	Flat Washer	6.2 x 20 x 3.0T	4
27	**	Hex Head Screw w/thread locker	M8 x 1.25P x 20	1
28	**	Flat Washer	8.2 x 30 x 4.0T	1
29	**	Phillips Pan Hd. Machine Screw	M4 x 0.7P x 10	7
30	**	Cable Clamp	ACC-4-B	4
31	**	Head		1
32	**	Bracket Set		2
33	**	Socket Head Cap Screw	M8 x 1.25P x 20	4
34	**	Cut Limit Plate		1
35	**	Flat Head Machine Screw	M5 x 0.8P x 12	2
36	**	Bracket Set	3/8" x 1/2" x 390mm L	4
37	PM1-498	Compression Spring		3
38	PM1-499	Compression Spring		4
39	**	Tension Adjustment Screw		4
40	PM1-500	Roller Support Bracket		4
41	PM1-526	Rubber Coated Outfeed Roller		1
42	PM1-502	Chain		3
43	**	Flat Washer	6.2 x 22 x 3T	4
44	**	Hex Head Screw	M6 x 1.0P x 16	3
45	**	Self-Tapping Screw	M4 x 1.41P x 10	11
46	**	Left Safety Cover		1
47	PM1-503	Gearbox Chain Cover		1
48	PM1-527	Chain	#06B-44P	1
49	**	Right Safety Cover		1
50	**	Ball Bearing	6205VV	1
51	**	Single Round Key	8 x 8 x 36	1
52	PM1-528	Cutter Head Assembly		1
52.1	**	Cutter Head		1
52.2	PM1-506	Knife Insert (set of 10)	15 x 15 x 2.5	68
52.3	PM1-507	Knife Insert Screw		68

Index No.	Part No.	Description	Size	Qty
92	PM1-508	Signal Control Switch Assy		1
92.1	**	Switch Box Cover		1
92.2	**	PCB Bracket		1
92.3	**	OFF Button		1
92.4	**	ON Button		1
92.5	**	Safety Key		1
92.6	**	E-Stop Paddle		1
92.7	**	PCB		1
92.8	**	Self-Tapping Screw	M4 x 1.41P x 10	7
92.9	**	Switch Box		1
92.10	**	Compression Spring		4
93	**	Switch Plate		1
94	**	Socket Head Button Screw w/Thread Locker	M6 x 1.0P x 12	3
95	**	Press Plate		1
96	**	Infeed Roller		1
97	**	Worm Shaft		1
98	**	Ball Bearing	6200Z	1
99	**	Retaining Ring	RTW-30	1
100	**	Spacer		1
101	PM1-556	Handwheel		1
102	PM1-557	Handwheel Handle		1
104	**	Hex Nut	M12 x 1.75P	4
105	PM1-530	Chain	#06B-57P	1
106	**	DRO Support Bracket		1
107	**	Phillips Pan Head Machine Screw	M6 x 1.0P x 10	4
108	**	Depth Scale Holder		1
109	**	Socket Head Button Screw	M6 x 1.0P x 12	11
110	PM1-531	Depth Scale		1
111	PM1-510	DRO Assy		1
111.1	**	DRO Box		1
111.2	**	Phillips Pan Head Machine Screw	M3 x 0.5P x 15	4
111.3	**	Screen	3.2" TFT	1
111.4	**	Standoff		4
111.5	**	PCB		1
111.6	**	Plastic Nut	PN3 (M3)	4
111.7	**	Self-Tapping Screw	M3 x 1.06P x 8	4
111.9	**	Connection Cable	24AWG x 4C x 100mm	1
143	**	Flat Washer	12.1 x 24 x 4T	4
193	**	Foam Pad	3/8" x 1/2" x 520mm L	1
207	**	Double Round Key	4 x 4 x 15	1
220	**	Strain Relief	SB5M-2	1
222	**	Direction Indication Label		1
227	**	Cable Clip		1
229	**	Depth Scale Plate		1

** These parts are shown for reference only and are not available for order individually. Non-proprietary parts, such as fasteners, can usually be found at local hardware stores.

12.3.1 Base Assembly – Exploded View

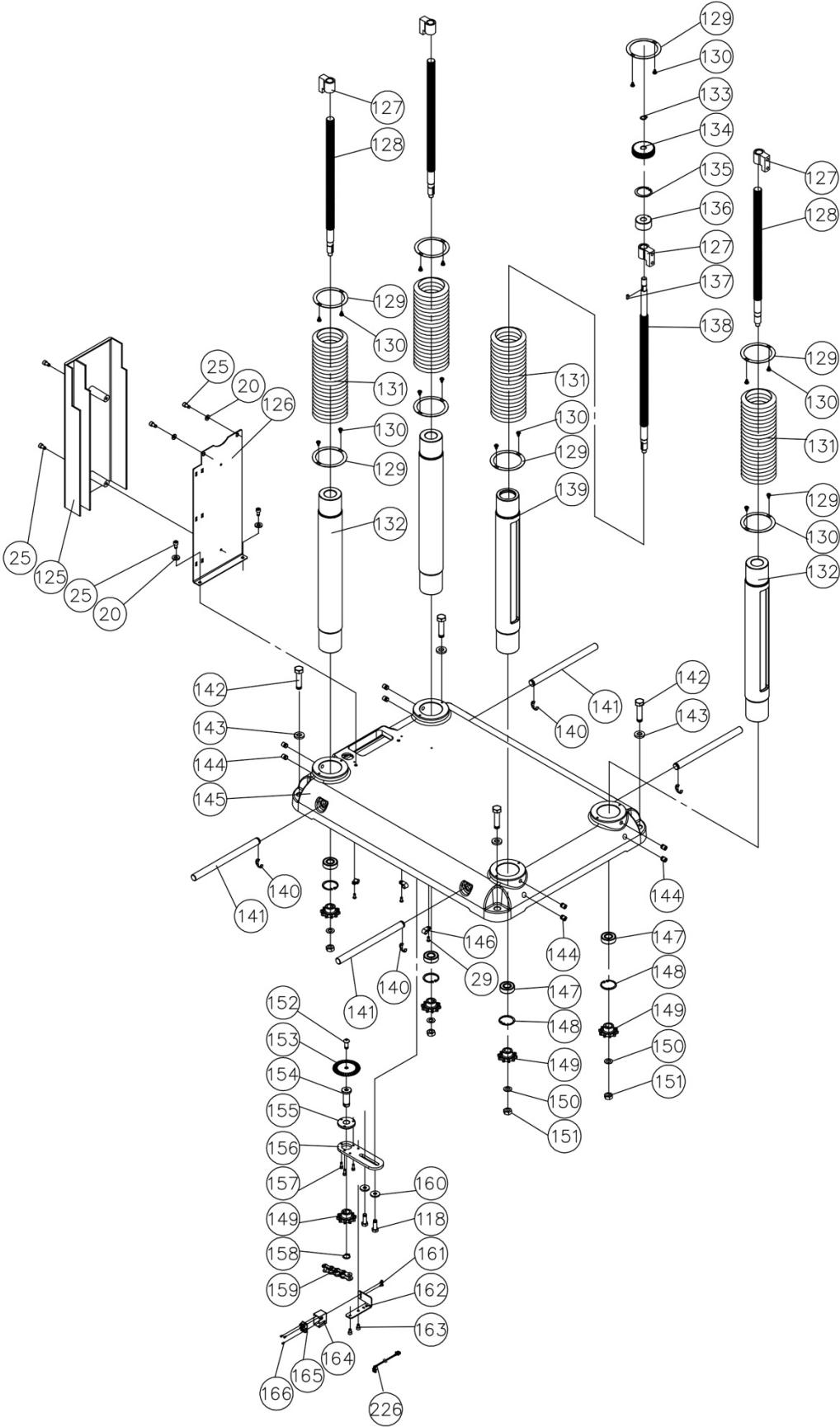

12.3.2 Base Assembly – Parts List

Index No.	Part No.	Description	Size	Qty
20	**	Flat Washer	6.3 x 13 x 2.0T	2
25	**	Socket Head Cap Screw	M6 x 1.0P x 12	6
29	**	Phillips Pan Hd. Machine Screw	M4 x 0.7P x 10	1
125	PM1-532	Drive Belt Cover		1
126	**	Drive Belt Cover Bracket		1
127	**	Lead Screw Nut		4
128	**	Driven Lead Screw		3
129	**	Dust Proof Cover Fixed Ring		16
130	**	Self-Tapping Screw	M5 x 2.12P x 10	32
131	**	Dust Proof Cover		8
132	**	Driven Lead Screw Column		3
133	**	Retaining Ring	STW-12	1
134	**	Worm		1
135	**	Retaining Ring	RTW-38	1
136	**	Collar		1
137	**	Double Round Key	4 x 4 x 12	1
138	**	Drive Lead Screw		1
139	**	Drive Lead Screw Column		1
140	**	Retaining Ring	ETW-12	4
141	**	Lift Rod		4
142	**	Hex Head Screw	M12 x 1.75P x 50	4
143	**	Flat Washer	12.1 x 24 x 4T	4
144	**	Socket Head Set Screw	M10 x 1.5P x 12	8
145	**	Base		1
146	**	Cable Clamp	ACC-2.5	3
147	**	Ball Bearing	6202Z	4
148	**	Retaining Ring	RTW-35	4
149	**	Sprocket		5
150	**	Flat Washer	10.5 x 19 x 1.5T	4
151	**	Hex Head Screw	M10 x 1.25P	4
152	**	Socket Head Button Screw w/thread locker	M8 x 1.25P x 20	1
153	**	Sensing Disc		1
154	**	Sprocket Shaft		1
155	**	Hub		1
156	**	Bracket		1
157	**	Socket Head Cap Screw	M4 x 0.7P x 12	3
158	**	Retaining Ring	STW-15	1
159	**	Chain	#40 x 166P	1
160	**	Flat Washer	8.2 x 22 x 3.0T	2
161	**	Self-tapping Screw	M3 x 1.06P x 8	2
162	**	Sensor Support Bracket		1
163	**	Socket Head Cap Screw	M5 x 0.8P x 8	2
164	PM1-513	Sensor Cover		1
165	PM1-533	Sensor		1
166	**	Self-tapping Screw	M2 x 0.63P x 6	3
226	**	Connection Cable	24AWG x 4C x 1600mm	1

** These parts are shown for reference only and are not available for order individually. Non-proprietary parts, such as fasteners, can usually be found at local hardware stores.

12.4.1 Gearbox Assembly – Exploded View

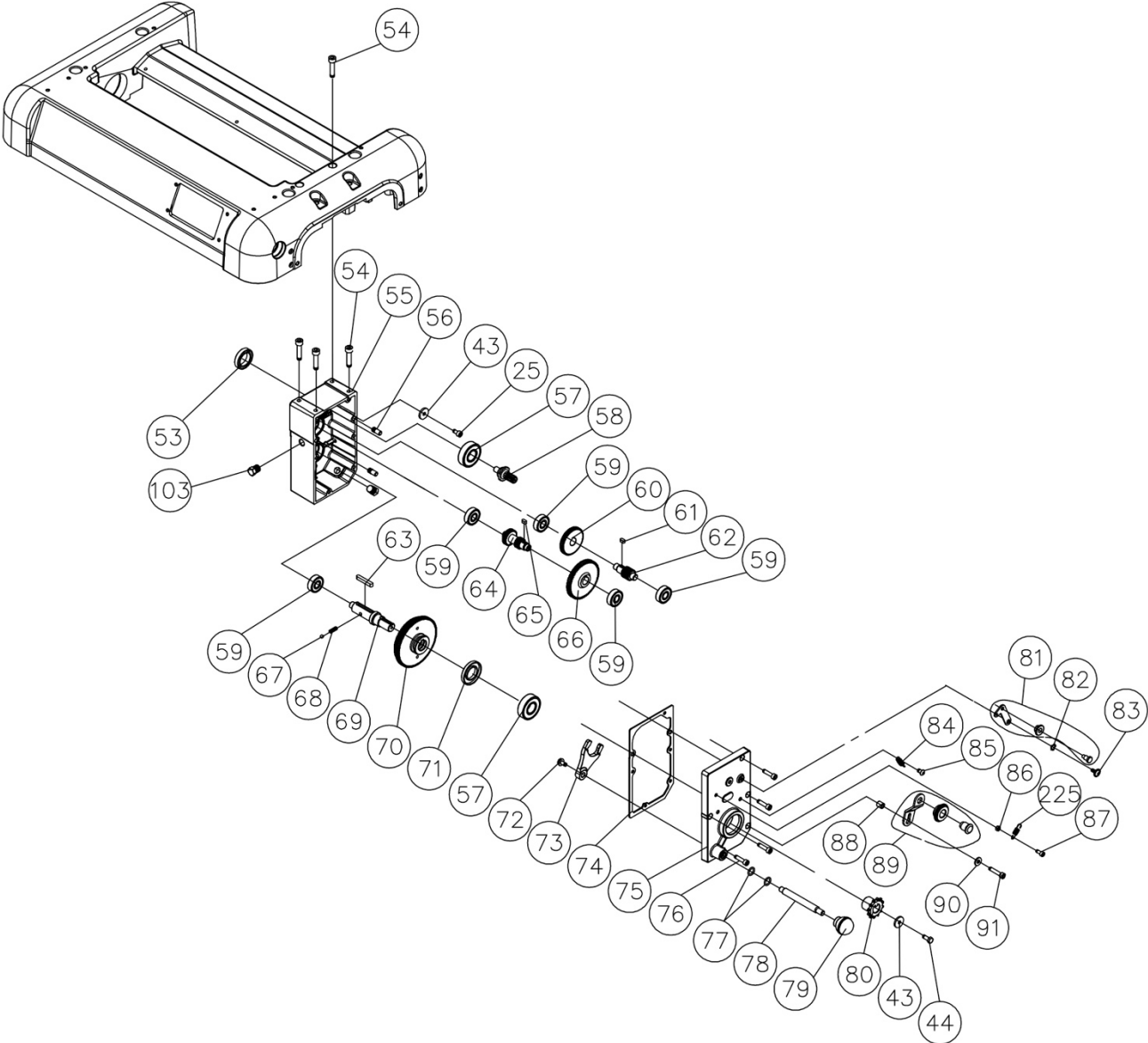

12.4.2 Gearbox Assembly – Parts List

Index No.	Part No.	Description	Size	Qty
25	**	Socket Head Cap Screw	M6 x 1.0P x 12	1
43	**	Flat Washer	6.2 x 22 x 3T	2
44	**	Hex Head Screw	M6 x 1.0P x 16	1
53	**	Oil Seal	TCX4 28 x 40 x 8	1
54	**	Socket Head Cap Screw w/thread locker	M8 x 1.25P x 35	4
55	**	Gearbox		1
56	**	Pin		2
57	**	Ball Bearing	6204VV	2
58	**	Drive Gear		1
59	**	Ball Bearing	6201ZZ	5
60	**	Gear	52T	1
61	**	Double Round Key	5 x 5 x 12	1
62	**	Shaft		1
63	**	Double Round Key	6 x 6 x 40	1
64	**	Shaft		1
65	**	Double Round Key	5 x 5 x 10	1
66	**	Gear		1
67	**	Steel Ball	dia. 6mm	1
68	**	Compression		1
69	**	Shaft		1
70	**	Double Gear Assembly		1
71	**	Oil Seal	SC25 x 47 x 6	1
72	**	Hex Head Screw w/Thread Locker & Flat Washer	M6 x 1.0P x 12	1
73	**	Clutch		1
74	PM1-514	Gasket		1
75	**	Gearbox Cover		1
76	**	Socket Head Cap Screw	M6 x 1.0P x 25	4
77	**	O-ring	P12	2
78	**	Clutch Shaft		1
79	**	Ball Knob		1
80	**	Chain	12T	1
81	**	Upper Idler Assembly		1
82	**	Wave Washer	WW-8	1
83	**	Shoulder Screw		1
84	PM1-515	Tension Spring		1
85	**	Socket Head Button Screw	M6 x 1.0P x 10	1
86	**	Hex Nut	M5 x 0.8P	1
87	**	Socket Head Cap Screw	M5 x 0.8P x 12	5
88	**	Bushing		1
89	**	Lower Idler Assembly		1
90	**	Flat Washer	6.7 x 16 x 2.0T	1
91	**	Socket Head Cap Screw	M6 x 1.0P x 30	1
103	**	Oil Plug	PT1/4"-19	2
225	**	Compression Spring		1

** These parts are shown for reference only and are not available for order individually. Non-proprietary parts, such as fasteners, can usually be found at local hardware stores.

12.5.1 Cabinet Assembly – Exploded View

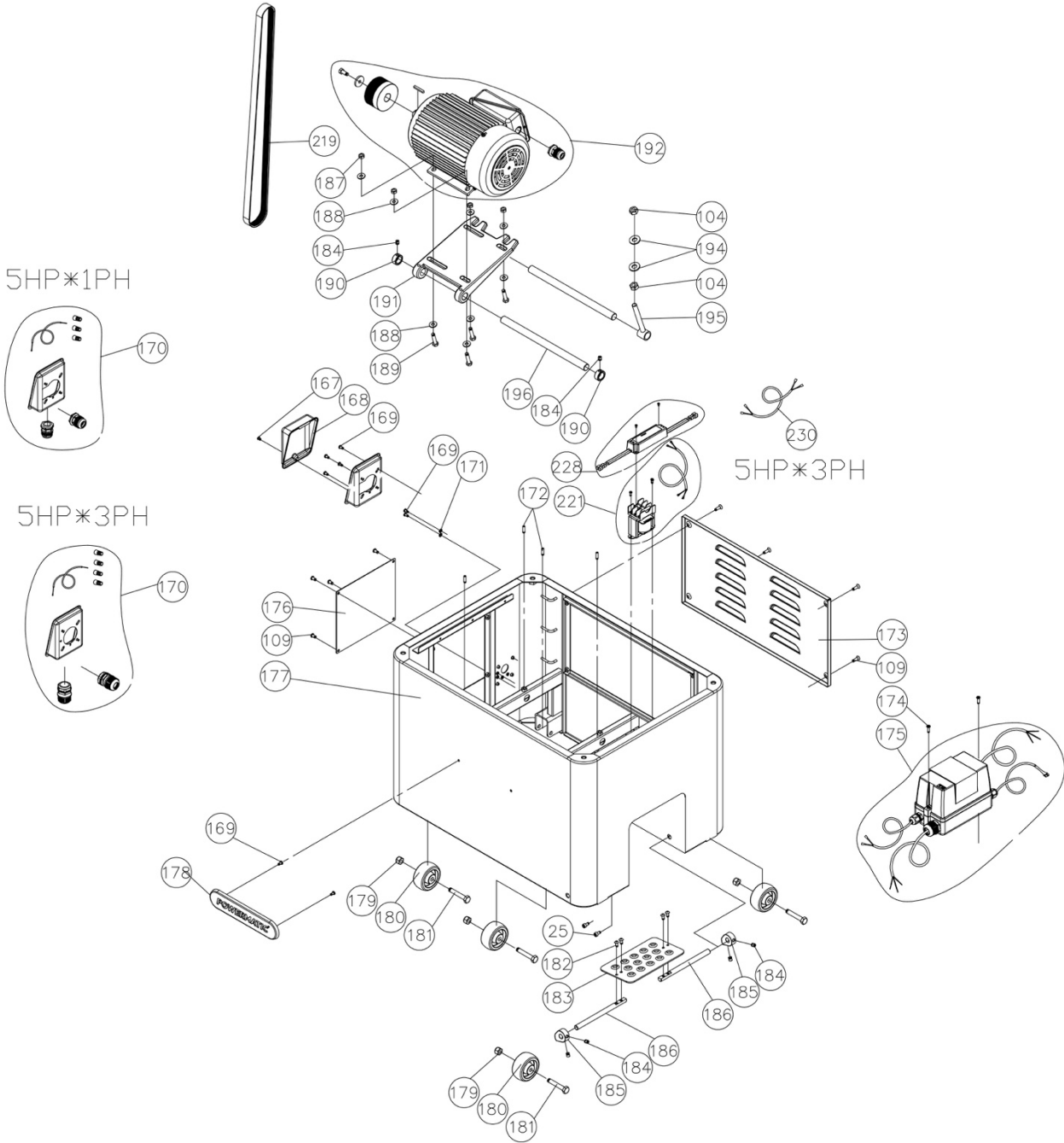

12.5.2 Cabinet Assembly – Parts List

Index No.	Part No.	Description	Size	Qty
25	**	Socket Head Cap Screw	M6 x 1.0P x 12	2
167	**	Phillips Pan Head Machine Screw	3/16 - 24UNC x 1/4	1
168	**	Wiring Box Cover	SB8R-3	1
169	**	Phillips Pan Head Machine Screw	M5 x 0.8P x 10	8
170	PM1-534	Wiring Box & Leads Set for 209BHH		1
	PM1-535	Wiring Box & Leads Set for 209BHH-3		1
171	**	External-Tooth Star Lock Washer	5 x 10 x 0.6T	2
172	**	Socket Head Set Screw	M6 x 1.0P x 20	2
173	**	Cabinet Rear Cover		1
174	**	Phillips Pan Head Machine Screw	M5 x 0.8P x 18	2
175	PM1-536	Magnetic Switch Assembly	5HP x 230V x 1PH	1
	PM1-537	Magnetic Switch Assembly	5HP x 230V x 3PH	1
	PM1-538	Magnetic Switch Assembly	5HP x 460V x 3PH	1
176	**	Cabinet Side Cover		1
177	**	Cabinet		1
178	**	Logo Badge		1
179	**	Nylon Lock Hex Nut	M10 x 1.5P	4
180	PM1-517	Wheel		4
181	**	Hex Head Screw	M10 x 1.5P x 65	4
182	**	Socket Head Button Screw w/thread locker	M6 x 1.0P x 12	4
183	**	Brake Pedal		1
184	**	Socket Head Set Screw	M8 x 1.25P x 10	6
185	**	Cam Lock		2
186	**	Brake Pedal Pivot		2
187	**	Hex Nut	M8 x 1.25P	4
188	**	Flat Washer	8.5 x 20 x 2.0T	8
189	**	Hex Head Screw	M8 x 1.25P x 35	4
190	**	Spacer		2
191	**	Motor Plate		1
192	PM1-539	Motor	5HP x 230V x 60HZ x 1PH	1
	PM1-540	Motor	5HP x 230V x 60HZ x 3PH	1
194	**	Flat Washer	13 x 28 x 3.0T	2
195	**	Belt Tension Adjustment Rod		1
196	**	Motor Plate Shaft		2
219	PM1-541	Poly-V Belt	560J-12	1
221	PM1-524	Transformer Set for 209BHH-3		1
223	**	Rubber Pad		2
224	**	Cable Tie	ALT-102S-B	9
228	**	Power Module Assembly		1
230	**	Connection Cable	SJT18AWG*2C*300mm	1

** These parts are shown for reference only and are not available for order individually. Non-proprietary parts, such as fasteners, can usually be found at local hardware stores.

13.0 Electrical Connections

Single Phase, 230 Volt Only

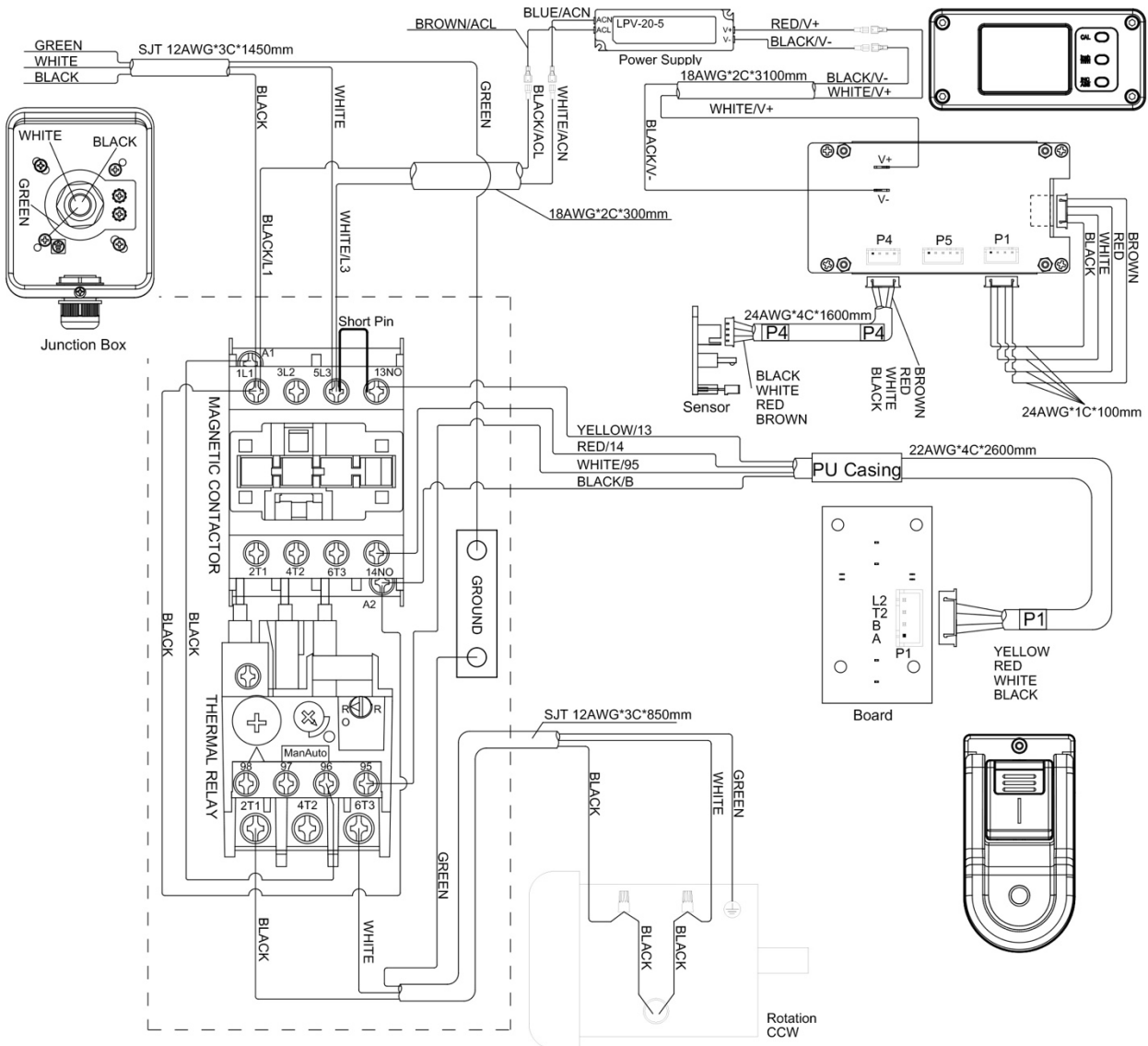

Three Phase, 230 Volt Only

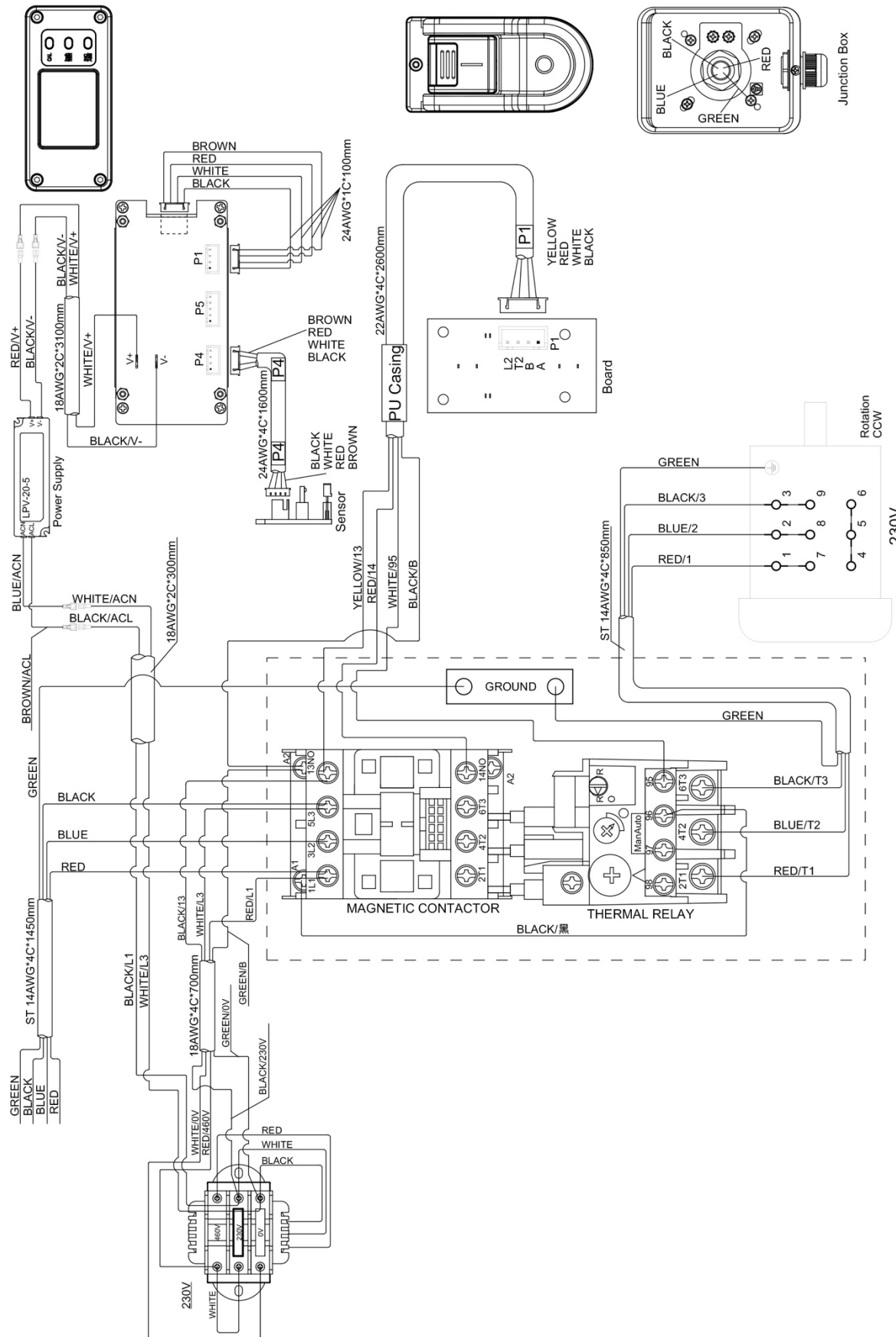

Three Phase, 460 Volt Only

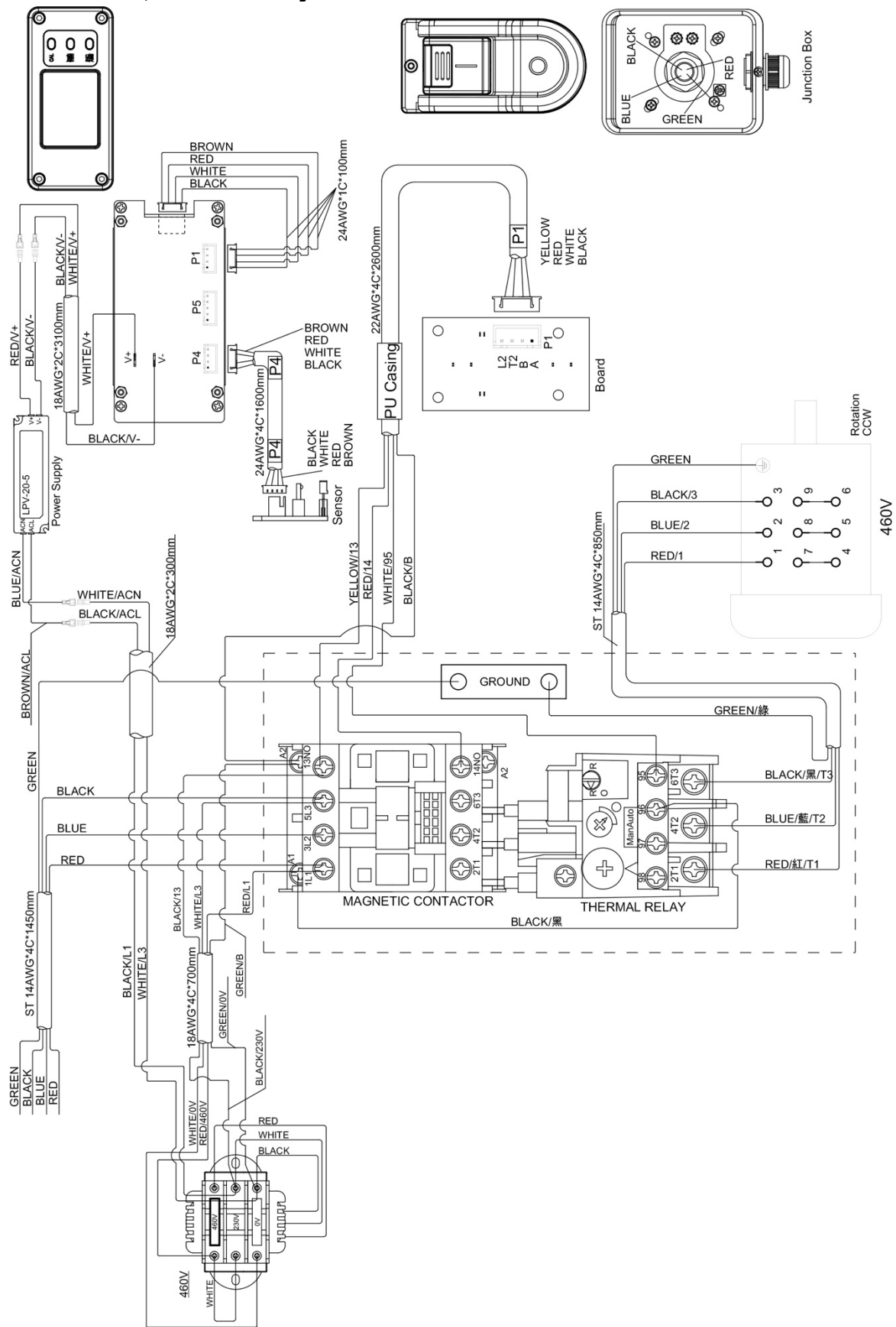

14.0 Warranty and Service

Powermatic warrants every product it sells against manufacturers' defects. If one of our tools needs service or repair, please contact Technical Service by calling 1-800-274-6846, 8AM to 5PM CST, Monday through Friday.

Warranty Period

The general warranty lasts for the time period specified in the literature included with your product or on the official Powermatic branded website.

- Powermatic products carry a limited warranty which varies in duration based upon the product. (See chart below)
- Accessories carry a limited warranty of one year from the date of receipt.
- Consumable items are defined as expendable parts or accessories expected to become inoperable within a reasonable amount of use and are covered by a 90 day limited warranty against manufacturer's defects.

Who is Covered

This warranty covers only the initial purchaser of the product from the date of delivery.

What is Covered

This warranty covers any defects in workmanship or materials subject to the limitations stated below. This warranty does not cover failures due directly or indirectly to misuse, abuse, negligence or accidents, normal wear-and-tear, improper repair, alterations or lack of maintenance. Powermatic woodworking machinery is designed to be used with Wood. Use of these machines in the processing of metal, plastics, or other materials outside recommended guidelines may void the warranty. The exceptions are acrylics and other natural items that are made specifically for wood turning.

Warranty Limitations

Woodworking products with a Five Year Warranty that are used for commercial or industrial purposes default to a Two Year Warranty. Please contact Technical Service at 1-800-274-6846 for further clarification.

How to Get Technical Support

Please contact Technical Service by calling 1-800-274-6846. **Please note that you will be asked to provide proof of initial purchase when calling.** If a product requires further inspection, the Technical Service representative will explain and assist with any additional action needed. Powermatic has Authorized Service Centers located throughout the United States. For the name of an Authorized Service Center in your area call 1-800-274-6846 or use the Service Center Locator on the Powermatic website.

More Information

Powermatic is constantly adding new products. For complete, up-to-date product information, check with your local distributor or visit the Powermatic website.

How State Law Applies

This warranty gives you specific legal rights, subject to applicable state law.

Limitations on This Warranty

POWERMATIC LIMITS ALL IMPLIED WARRANTIES TO THE PERIOD OF THE LIMITED WARRANTY FOR EACH PRODUCT. EXCEPT AS STATED HEREIN, ANY IMPLIED WARRANTIES OF MERCHANTABILITY AND FITNESS FOR A PARTICULAR PURPOSE ARE EXCLUDED. SOME STATES DO NOT ALLOW LIMITATIONS ON HOW LONG AN IMPLIED WARRANTY LASTS, SO THE ABOVE LIMITATION MAY NOT APPLY TO YOU. POWERMATIC SHALL IN NO EVENT BE LIABLE FOR DEATH, INJURIES TO PERSONS OR PROPERTY, OR FOR INCIDENTAL, CONTINGENT, SPECIAL, OR CONSEQUENTIAL DAMAGES ARISING FROM THE USE OF OUR PRODUCTS. SOME STATES DO NOT ALLOW THE EXCLUSION OR LIMITATION OF INCIDENTAL OR CONSEQUENTIAL DAMAGES, SO THE ABOVE LIMITATION OR EXCLUSION MAY NOT APPLY TO YOU.

Powermatic sells through distributors only. The specifications listed in Powermatic printed materials and on the official Powermatic website are given as general information and are not binding. Powermatic reserves the right to effect at any time, without prior notice, those alterations to parts, fittings, and accessory equipment which they may deem necessary for any reason whatsoever.

Product Listing with Warranty Period

90 Days – Parts; Consumable items
1 Year – Motors, Machine Accessories
2 Year – Woodworking Machinery used for industrial or commercial purposes
5 Year – Woodworking Machinery

NOTE: Powermatic is a division of JPW Industries, Inc. References in this document to Powermatic also apply to JPW Industries, Inc., or any of its successors in interest to the Powermatic brand.

Preventive Maintenance Checklist

- [] Work area around machine marked off clearly.
- [] Non-skid floor strips in area where operator normally stands.
- [] Inspect entire machine for loose bolts, nuts, screws. Tighten and replace as necessary.
- [] Clean table and cutterhead area, removing sawdust and chips with a soft-bristle brush. Remove gum and pitch with oven cleaner.
- [] Lubricate appropriate places with a good grade non-hardening grease.
- [] Clean table surface. If rusted, use paste mixture of household ammonia, a good commercial detergent and 000 steel wool. Wash surface down with hot, soapy water, rinse and dry thoroughly. Coat surface with talcum powder, rubbing briskly into surface with a clean blackboard eraser.
- [] Check blade condition; should be sharp and free of nicks or grooves.
- [] Check belt condition. Replace as needed. Dress with belt dressing. Check belt tension.
- [] Check motor for loose wiring and sawdust congestion, pulleys tight and in line.
- [] Check bearings. Replace any bad or suspect bearings immediately.
- [] Check leveling of extension tables with main table.



427 New Sanford Rd.
La Vergne, TN 37086
Phone: 855-657-GOLD
www.powermatic.com