

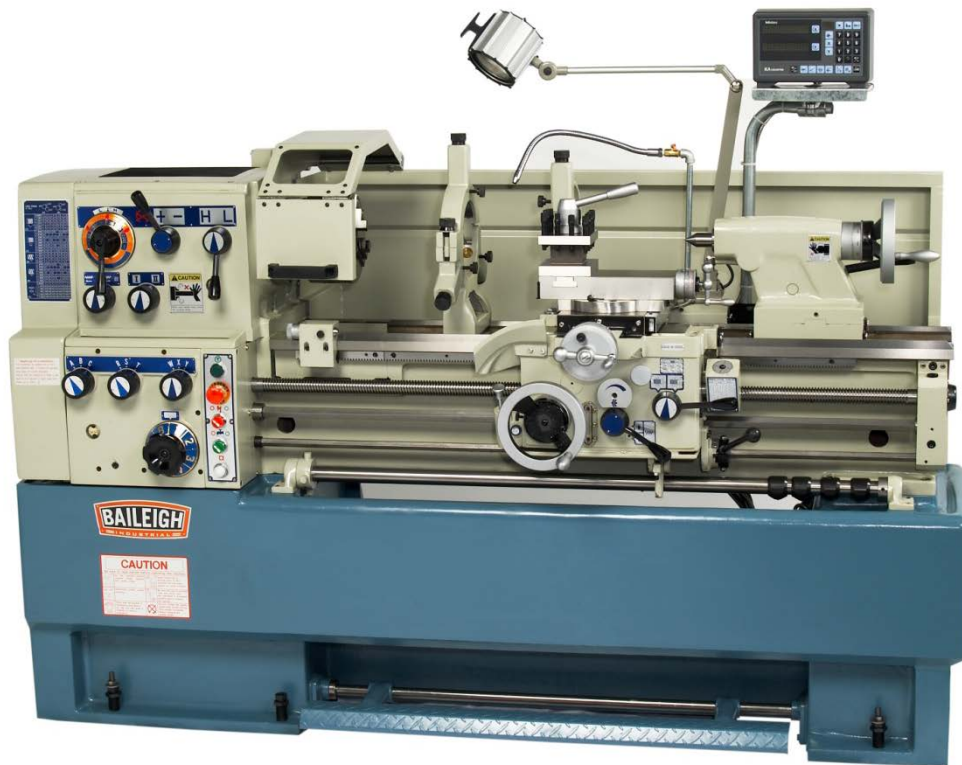

# OPERATOR'S MANUAL



## METAL LATHE MODEL: PL-1640

Baileigh Industrial, Inc.  
P.O. Box 531  
Manitowoc, WI 54221-0531  
Phone: 920.684.4990  
Fax: 920.684.3944  
[sales@baileighindustrial.com](mailto:sales@baileighindustrial.com)

Book 1 of 3

REPRODUCTION OF THIS MANUAL IN ANY FORM WITHOUT WRITTEN APPROVAL OF BAILEIGH INDUSTRIAL, INC. IS PROHIBITED. Baileigh Industrial, Inc. does not assume and hereby disclaims any liability for any damage or loss caused by an omission or error in this Operator's Manual, resulting from accident, negligence, or other occurrence.

Rev. 10/2013



## Table of Contents

THANK YOU & WARRANTY .....	4
INTRODUCTION.....	6
DESCRIPTION.....	6
GENERAL NOTES.....	6
SAFETY INSTRUCTIONS .....	7
WARNING - Operator Safety Precautions .....	9
TECHNICAL SPECIFICATIONS.....	11
Machine Features .....	11
OVERALL DIMENSIONS.....	12
TRANSPORTING THE MACHINE .....	13
UNPACKING AND CHECKING CONTENTS.....	13
CLEANING.....	16
MACHINE LOCATION .....	16
LIFTING AND MOVING THE LATHE.....	17
Level Adjustment.....	19
ELECTRICAL.....	20
Power cord connection:.....	21
SAFETY FEATURES .....	22
GETTING TO KNOW YOUR MACHINE .....	23
Steady Rest.....	25
Follow Rest .....	25
Dead Center.....	26
Tailstock.....	26
Quick Change Tool Posts.....	27
LATHE SETUP.....	28
Chuck.....	28
To Remove a Chuck .....	29
To Install a Chuck .....	30
To Install Cam lock Studs.....	30
Symbols for Operation .....	31
Coolant System.....	33
OPERATING CONTROLS .....	33
Spindle Speeds .....	34
Feed Direction.....	35
Feed Selector Knobs.....	36
Thread Cutting and Feed Chart.....	37
Thread Cutting Operation.....	39
APRON .....	39
Feeds – manual .....	39
Feeds – power: .....	39
Feed Disengagement.....	40
Threading.....	41
Thread Dial Indicator.....	41
Spindle Rotation Control .....	42
Micrometer Saddle Stop.....	42



Saddle – cross slide and compound rest .....	43
Cross Traverse Slide.....	43
Compound Rest .....	44
Half Nut .....	44
Lead Screw .....	45
Changing Gears for Thread Selection.....	45
TEST RUN .....	46
MACHINE ADJUSTMENTS .....	47
Spindle Bearing Adjustment .....	47
Tapered Gib Adjustment .....	48
Lathe Alignment .....	48
Half Nut Adjustment .....	49
Lead Screw Adjustment .....	49
V-Belt Removal and Adjustment .....	50
Cross feed Screw / Nut Backlash Adjustment .....	52
Feed Rod Adjustment .....	53
LUBRICATION AND MAINTENANCE .....	54
Headstock .....	54
Quick Change Gear Box .....	55
Apron .....	55
Lead screw, Feed Rod, and Half Nut .....	55
Bed Ways, Saddle, and Cross Slide .....	56
Tail Stock .....	56
Daily Maintenance.....	58
Weekly Maintenance .....	58
3 Month Maintenance.....	58
Oil Disposal.....	58
Accessing and Cleaning the Coolant System.....	58
Oils for Lubricating Coolant.....	58
Storing Machine for Extended Period of Time.....	59



## **THANK YOU & WARRANTY**

Thank you for your purchase of a machine from Baileigh Industrial. We hope that you find it productive and useful to you for a long time to come.

**Inspection & Acceptance.** Buyer shall inspect all Goods within ten (10) days after receipt thereof. Buyer's payment shall constitute final acceptance of the Goods and shall act as a waiver of the Buyer's rights to inspect or reject the goods unless otherwise agreed. If Buyer rejects any merchandise, Buyer must first obtain a Returned Goods Authorization ("RGA") number before returning any goods to Seller. Goods returned without a RGA will be refused. Seller will not be responsible for any freight costs, damages to goods, or any other costs or liabilities pertaining to goods returned without a RGA. Seller shall have the right to substitute a conforming tender. Buyer will be responsible for all freight costs to and from Buyer and repackaging costs, if any, if Buyer refuses to accept shipment. If Goods are returned in unsalable condition, Buyer shall be responsible for full value of the Goods. Buyer may not return any special order Goods. Any Goods returned hereunder shall be subject to a restocking fee equal to 30% of the invoice price.

**Specifications.** Seller may, at its option, make changes in the designs, specifications or components of the Goods to improve the safety of such Goods, or if in Seller's judgment, such changes will be beneficial to their operation or use. Buyer may not make any changes in the specifications for the Goods unless Seller approves of such changes in writing, in which event Seller may impose additional charges to implement such changes.

**Limited Warranty.** Seller warrants to the original end-user that the Goods manufactured or provided by Seller under this Agreement shall be free of defects in material or workmanship for a period of twelve (12) months from the date of purchase, provided that the Goods are installed, used, and maintained in accordance with any instruction manual or technical guidelines provided by the Seller or supplied with the Goods, if applicable. The original end-user must give written notice to Seller of any suspected defect in the Goods prior to the expiration of the warranty period. The original end-user must also obtain a RGA from Seller prior to returning any Goods to Seller for warranty service under this paragraph. Seller will not accept any responsibility for Goods returned without a RGA. The original end-user shall be responsible for all costs and expenses associated with returning the Goods to Seller for warranty service. In the event of a defect, Seller, at its sole option, shall repair or replace the defective Goods or refund to the original end-user the purchase price for such defective Goods. Goods are not eligible for replacement or return after a period of 30 days from date of receipt. The foregoing warranty is Seller's sole obligation, and the original end-user's exclusive remedy, with regard to any defective Goods. This limited warranty does not apply to: (a) die sets, tooling, and saw blades; (b) periodic or routine maintenance and setup, (c) repair or replacement of the Goods due to normal wear and tear, (d) defects or damage to the Goods resulting from misuse, abuse, neglect, or accidents, (e) defects or damage to the Goods resulting from improper or unauthorized alterations, modifications, or changes; and (f) any Goods that has not been installed and/or maintained in accordance with the instruction manual or technical guidelines provided by Seller.

**EXCLUSION OF OTHER WARRANTIES.** THE FOREGOING LIMITED WARRANTY IS IN LIEU OF ALL OTHER WARRANTIES, EXPRESS OR IMPLIED. ANY AND ALL OTHER EXPRESS, STATUTORY OR IMPLIED WARRANTIES, INCLUDING BUT NOT LIMITED TO, ANY WARRANTY OF MERCHANTABILITY OR FITNESS FOR ANY PARTICULAR PURPOSE ARE EXPRESSLY DISCLAIMED. NO WARRANTY IS MADE WHICH EXTENDS BEYOND THAT WHICH IS EXPRESSLY CONTAINED HEREIN.

**Limitation of Liability.** IN NO EVENT SHALL SELLER BE LIABLE TO BUYER OR ANY OTHER PARTY FOR ANY INCIDENTAL, CONSEQUENTIAL OR SPECIAL DAMAGES (INCLUDING, WITHOUT LIMITATION, LOST PROFITS OR DOWN TIME) ARISING FROM OR IN MANNER CONNECTED WITH THE GOODS, ANY BREACH BY SELLER OR ITS AGENTS OF THIS AGREEMENT, OR ANY OTHER CAUSE WHATSOEVER, WHETHER BASED ON CONTRACT, TORT OR ANY OTHER THEORY OF LIABILITY. BUYER'S REMEDY WITH RESPECT TO ANY CLAIM ARISING UNDER THIS AGREEMENT IS STRICTLY LIMITED TO NO MORE THAN THE AMOUNT PAID BY THE BUYER FOR THE GOODS.



Force Majeure. Seller shall not be responsible for any delay in the delivery of, or failure to deliver, Goods due to causes beyond Seller's reasonable control including, without limitation, acts of God, acts of war or terrorism, enemy actions, hostilities, strikes, labor difficulties, embargoes, non-delivery or late delivery of materials, parts and equipment or transportation delays not caused by the fault of Seller, delays caused by civil authorities, governmental regulations or orders, fire, lightening, natural disasters or any other cause beyond Seller's reasonable control. In the event of any such delay, performance will be postponed by such length of time as may be reasonably necessary to compensate for the delay.

Installation. If Buyer purchases any Goods that require installation, Buyer shall, at its expense, make all arrangements and connections necessary to install and operate the Goods. Buyer shall install the Goods in accordance with any Seller instructions and shall indemnify Seller against any and all damages, demands, suits, causes of action, claims and expenses (including actual attorneys' fees and costs) arising directly or indirectly out of Buyer's failure to properly install the Goods.

Work By Others; Safety Devices. Unless agreed to in writing by Seller, Seller has no responsibility for labor or work performed by Buyer or others, of any nature, relating to design, manufacture, fabrication, use, installation or provision of Goods. Buyer is solely responsible for furnishing, and requiring its employees and customers to use all safety devices, guards and safe operating procedures required by law and/or as set forth in manuals and instruction sheets furnished by Seller. Buyer is responsible for consulting all operator's manuals, ANSI or comparable safety standards, OSHA regulations and other sources of safety standards and regulations applicable to the use and operation of the Goods.

Remedies. Each of the rights and remedies of Seller under this Agreement is cumulative and in addition to any other or further remedies provided under this Agreement or at law or equity.

Attorney's Fees. In the event legal action is necessary to recover monies due from Buyer or to enforce any provision of this Agreement, Buyer shall be liable to Seller for all costs and expenses associated therewith, including Seller's actual attorneys' fees and costs.

Governing Law/Venue. This Agreement shall be construed and governed under the laws of the State of Wisconsin, without application of conflict of law principles. Each party agrees that all actions or proceedings arising out of or in connection with this Agreement shall be commenced, tried, and litigated only in the state courts sitting in Manitowoc County, Wisconsin or the u.s. Federal Court for the Eastern District of Wisconsin. Each party waives any right it may have to assert the doctrine of "forum non conveniens" or to object to venue to the extent that any proceeding is brought in accordance with this section. Each party consents to and waives any objection to the exercise of personal jurisdiction over it by courts described in this section. Each party waives to the fullest extent permitted by applicable law the right to a trial by jury.

#### Summary of Return Policy.

10 Day acceptance period from date of delivery. Damage claims and order discrepancies will not be accepted after this time.

You must obtain a Baileigh issued RGA number PRIOR to returning any materials.

Returned materials must be received at Baileigh in new condition and in original packaging.

Altered items are not eligible for return.

Buyer is responsible for all shipping charges.

A 30% re-stocking fee applies to all returns.

Baileigh Industrial makes every effort to ensure that our posted specifications, images, pricing and product availability are as correct and timely as possible. We apologize for any discrepancies that may occur. Baileigh Industrial reserves the right to make any and all changes deemed necessary in the course of business including but not limited to pricing, product specifications, quantities, and product availability.

#### For Customer Service & Technical Support:

Please contact one of our knowledgeable Sales and Service team members at:

(920) 684-4990 or e-mail us at [sales@baileighindustrial.com](mailto:sales@baileighindustrial.com)



## **INTRODUCTION**

*The quality and reliability of the components assembled on a Baileigh Industrial machine guarantee near perfect functioning, free from problems, even under the most demanding working conditions. However if a situation arises, refer to the manual first. If a solution cannot be found, contact the distributor where you purchased our product. Make sure you have the serial number and production year of the machine. (stamped on the nameplate). For replacement parts refer to the assembly numbers on the parts list drawings.*

*Our technical staff will do their best to help you get your machine back in working order.*

## **DESCRIPTION**

The Baileigh **PL-1640** is a precision gear head lathe that is capable of producing extremely accurate parts in less time. The large gearbox allows for large threading and feed capabilities. Ground and hardened gears are standard in the gearbox and headstock. The **PL-1640** comes standard with a 2 axis DRO (digital read out), a three jaw chuck, a steady rest, a follow rest, and a halogen work light. Each lathe has Meehanite® castings with hardened and ground ways coated with Turcite-B® for longer wear and tight tolerances.

### **In this manual you will find:**

- Safety procedures
- Correct installation guidelines
- Description of the functional parts of the machine
- Capacity charts
- Set-up and start-up instructions
- Machine operation
- Scheduled maintenance
- Parts lists

## **GENERAL NOTES**

- After receiving your equipment remove the protective crating. Do a complete visual inspection, and if damage is noted, **photograph it for insurance claims** and contact your carrier at once, requesting inspection. Also contact Baileigh Industrial and inform them of the unexpected occurrence. Temporarily suspend installation.
- Take necessary precautions while loading / unloading or moving the machine to avoid any injuries. Refer to the related chapter of this Manual for the best way of handling the machine.



## PLEASE READ THIS OPERATORS MANUAL CAREFULLY

It contains important safety information, instructions, and necessary operating procedures. The continual observance of these procedures will help increase your production and extend the life of the equipment.

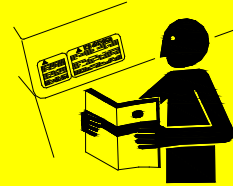

## SAFETY INSTRUCTIONS

### LEARN TO RECOGNIZE SAFETY INFORMATION

This is the safety alert symbol. When you see this symbol on your machine or in this manual, **BE ALERT TO THE POTENTIAL FOR PERSONAL INJURY!**

Follow recommended precautions and safe operating practices.



### UNDERSTAND SIGNAL WORDS

A signal word – **DANGER**, **WARNING**, or **CAUTION** is used with the safety alert symbol. **DANGER** identifies a hazard or unsafe practice that will result in severe **Injury or Death**.

Safety signs with signal word **DANGER** or **WARNING** are typically near specific hazards.

General precautions are listed on **CAUTION** safety signs. **CAUTION** also calls attention to safety messages in this manual.



**DANGER**



**WARNING**



**CAUTION**



### **PROTECT EYES**

Wear safety glasses or suitable eye protection when working on or around machinery.

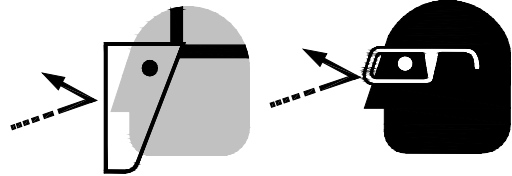

### **ROTATING CHUCK CAN CUT, DISMEMBER, SNAG, and ENTRAP**

Keep hands and body clear while operating. Flying chips, sparks, and other particles can cause serious injury or death.

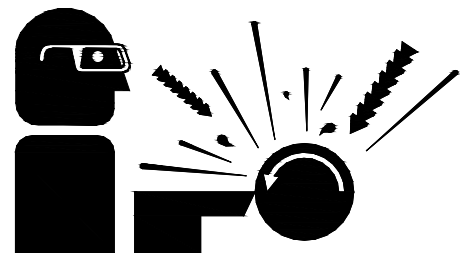

### **DUST HAZARD**

Wear appropriate dust mask when using this machinery.



### **HIGH VOLTAGE**

**USE CAUTION IN HIGH VOLTAGE AREAS.**  
**DO NOT** assume the power to be off.

**(MAKE SURE PROPER LOCKOUT PROCEDURES ARE FOLLOWED)**

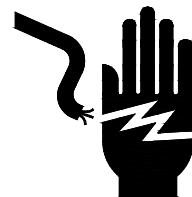

### **PROTECT AGAINST NOISE**

Prolonged exposure to loud noise can cause impairment or loss of hearing. Wear suitable hearing protective devices such as ear muffs or earplugs to protect against objectionable or uncomfortable loud noises.





## **WARNING - Operator Safety Precautions**

- 1) Read and understand the Operator's manual before using the lathe.
- 2) These lathes are fast, powerful machines which can cause severe bodily injury or death if not used properly and safety guidelines are not followed.
- 3) Always disconnect the lathe from the power supply before performing any service work, adjustments, or changing of tooling.
- 4) Do not wear clothing or jewelry that can become entangled in the moving machinery. Tie back long loose hair when operating the machine.
- 5) Remember - Safety is a combination of common sense and alertness at all times whether the machine is running or not. Never operate while under the influence of drugs or alcohol, or when tired.
- 6) Make sure lathe operators are properly trained. Untrained operators can be seriously injured. If the machine is not being used, disconnect and lockout the power to prevent unauthorized use of the machine.
- 7) Never leave adjustment tools or lathe chuck wrenches in the chuck or near any moving part of the machine. They can become dangerous projectiles causing serious personal injury or death.
- 8) Follow maintenance instructions and lubrication schedules to ensure the machine is in good working condition at all times.
- 9) Set up a scheduled machine inspection to look for damaged parts, loose hardware, misaligned components, or other conditions that will affect the safe operation of the machine.
- 10) Always use correct tooling and inserts for the job at hand, and make sure they are sharp to decrease strain on the machine components.
- 11) Study and understand the speed and feed charts on the machine and in this manual to avoid overloading the machine and causing possible tool damage.
- 12) Retro-fitting or purchasing a manual lathe with interlocking guards can help reduce the risk of entanglement or being hit with projectiles while operating the machine.



**WARNING - Operator Safety Precautions (cont.)**

- 13) Make sure guarding does not prevent the operator from performing the necessary job tasks in a safe manner.
- 14) Guards should not obscure the operator's view when extending beyond the depth of the chuck.
- 15) Always inspect the chuck and piece part in the chuck. Be aware of any potential catch points capable of causing serious personal injury or death.
- 16) To avoid injuries during start-up, make sure the piece part, tooling, and tool post have adequate clearance. Always set correct RPM for the size part being turned. If the speed is set too high for a large piece part there is a chance it could be ejected from the chuck causing serious personal injury or death.
- 17) Always support the piece part as necessary when it extends from the chuck using a lathe center in the tail stock or by using either a steady rest or a follow rest.
- 18) When the chuck and piece part are in motion, NEVER reach over, under, or around the piece part to make an adjustment or to retrieve anything.
- 19) ALWAYS STOP THE LATHE when removing metallic or plastic shavings from the piece part or the tooling. NEVER use your bare hands.



**WARNING**

All machinery poses a potential for danger when being operated. Accidents result from lack of machine knowledge and failure to pay attention. Always be cautious and alert to the potential for serious injury. Follow safety rules and precautions to lessen the chances of an accident.



**CAUTION**

No list of operator safety precautions can be complete as every shop has different surroundings and working conditions. Always put safety first as it applies to your work environment. Failure to do so can result in personal injury or equipment damage,



## TECHNICAL SPECIFICATIONS

Max.Swing Over Bed	16" (407mm)
Swing Over Cross Slide	9.45" (240mm)
Swing in Gap	
Diameter	23.42" (595mm)
Length	6.125" (155mm)
Center	
Height	7.086" (180mm)
Length	40" (1016mm)
Width of Bed	8.062" (205mm)
Length of Bed	74.75" (1900mm)
Height of Bed	12.20" (310mm)
Spindle Nose	D1-6"
Spindle Bore	2.0625" (52mm)
Spindle Taper (Sleeve)	Morse #4
Spindle Speeds	12 (30-2000 rpm)
Lead Screw Diameter	1.25 (32mm)
Lead Screw Thread	4 T.P.I.
Feed Rod	.708" (18mm) dia.
Threads Imperial (Qty / Speed)	40 / 2-56 T.P.I.

Threads Metric (Qty./Speed)	53 / .4-14mm pitch
Diametrical (qty. / type)	32 / 4 - 32 D.P.
Module (qty. / type)	44 / .4 - 7 M.P.
Longitudinal Feeds	
Imperial (Qty / Speed)	40 / .0012"-.0252" / rev.
Metric (Qty / Speed)	40 / .032 - .640mm / rev.
Cross Feeds	
Imperial (Qty / Speed)	40 / .0006"-.0126" / rev.
Metric (Qty / Speed)	40 / .015 - .320mm / rev.
Tailstock (quill) Dia.	2.125" (54mm)
Tailstock (quill) Travel	4.75" (120mm)
Tailstock (quill) Taper	Morse #4
Motor Coolant	1/8 Hp (.09Kw)
Main Motor	7.5 Hp (5.60Kw)
Power Requirements	220V, 3Ph
Shipping Dimensions (L x W x H)	91" x 65" x 44" (2311 x 1651 x 1,550mm)
Shipping Weight	4,400 lbs (2000Kg)

*Specifications subject to change without notice*

### Machine Features

- **2-axis digital readout**
- **8" (203mm) three jaw chuck**
- **12-step spindle speed**
- **Integrated coolant system**
- **Steady rest**
- **Follow rest**
- **Live center**
- **4-way quick change tool post with guard**
- **Foot brake**
- **Headstock chuck guard with micro switch safety cut-off**
- **Heavy duty welded stand**
- **220V three phase**



**Note:** *The specifications and dimensions presented here are subject to change without prior notice due to improvements of our products.*



# OVERALL DIMENSIONS

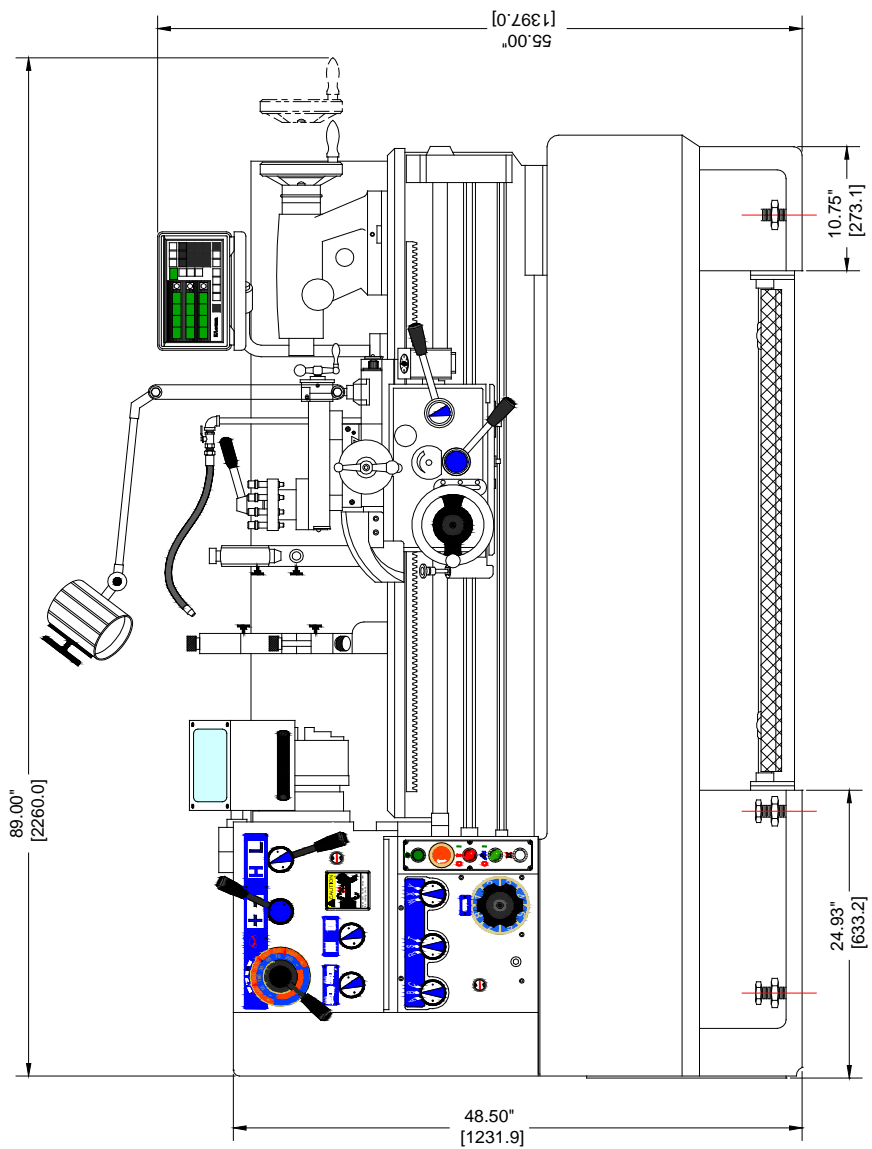
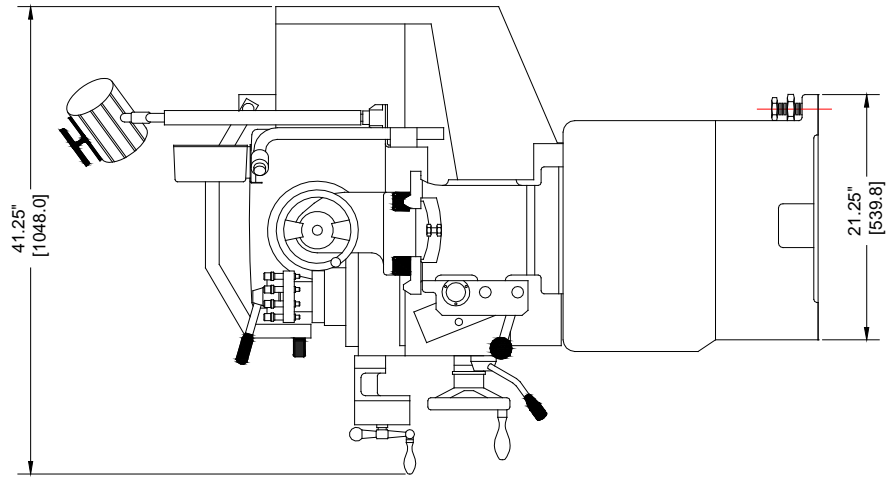

figure 1



## TRANSPORTING THE MACHINE



**Caution:** Lifting and carrying operations should be carried out by skilled workers, such as truck operator, crane operator, etc. Also, it is necessary to keep in mind that having a large clearance area around the machine is important for efficient and safe working conditions.

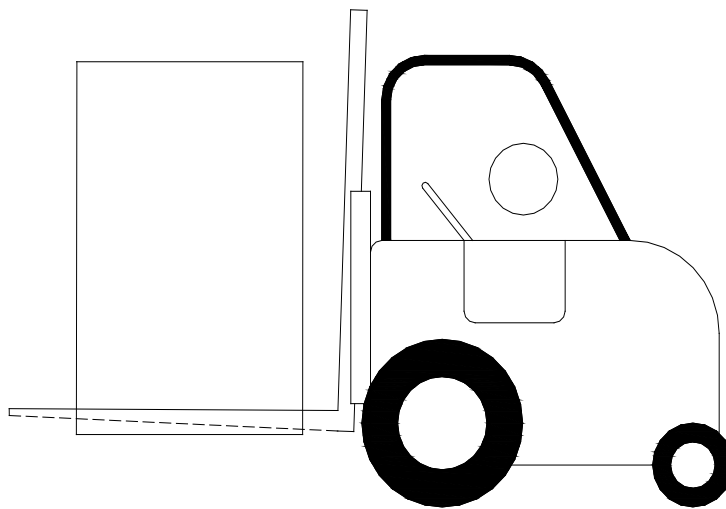

figure 2

When transporting in its own packaging,  
use a forklift truck or hand trolley.

## UNPACKING AND CHECKING CONTENTS

Your Baileigh **PL-1640** metal lathe is shipped complete in (1) wooden box.



**WARNING: SUFFOCATION HAZARD!** Immediately discard any plastic bags and packing materials to eliminate choking and suffocation hazards to children and animals.

After removing the box, carefully check the machine over for any damage. Remove all items from the tool box and do a complete inventory.



**UNPACKING AND CHECKING CONTENTS (cont.)**

Item	Description	Qty.
A	Tool Box	1
B	Lubricating Bottle	1
C	Tapered Sleeve	1
D	Reversing Jaws	3
E	Lathe Centers	2
F	Allen Wrenches (1.5 – 10mm)	1
G	Wheel Handle	1
H	Crescent Wrench	1
I	T-Handles	2
J	2-Pc T-Handle	1
K	Screw Drivers	2
L	Foot Pads	6
M	50 Amp Fuses	3
N	Change Gears – 31T, 41T	1ea.
O	5A Fuse (Attached to Tool Box Cover)	1
P	Brass Shear Pin (Attached to Tool Box Cover)	2



**UNPACKING AND CHECKING CONTENTS (cont.)**

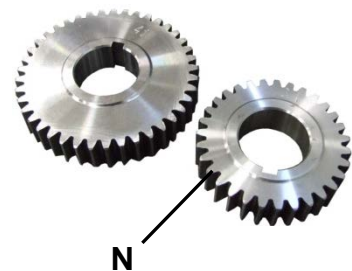
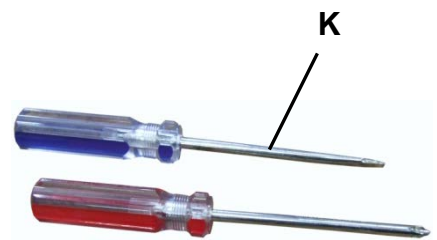
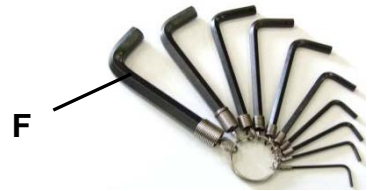
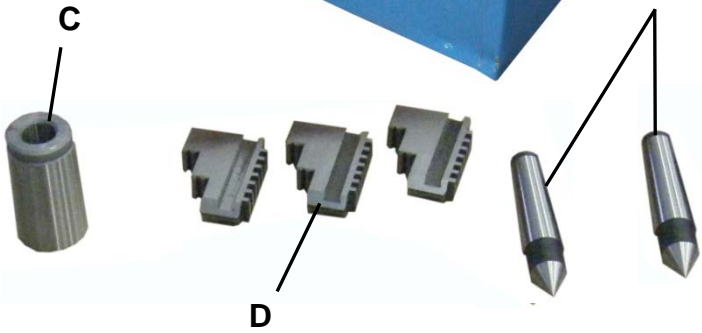
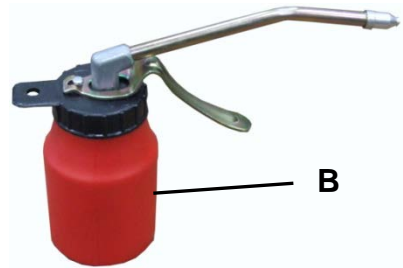



## CLEANING

Your machine may be shipped with a rustproof waxy oil coating and grease on the exposed unpainted metal surfaces. To remove this protective coating, use a degreaser or solvent cleaner. For a more thorough cleaning, some parts will occasionally have to be removed. **DO NOT USE** acetone or brake cleaner as they may damage painted surfaces.

Follow manufacturer's label instructions when using any type of cleaning product. After cleaning, wipe unpainted metal surfaces with a light coating of quality oil or grease for protection.

**⚠ WARNING:** DO NOT USE gasoline or other petroleum products to clean the machine. They have low flash points and can explode or cause fire.

**⚠ CAUTION:** When using cleaning solvents work in a well-ventilated area. Many cleaning solvents are toxic if inhaled.



## MACHINE LOCATION

Know the weight of your machine. Be sure the surface where the lathe will be placed will support the weight of the machine. Also include the weight of any additional equipment that may be installed on the lathe, operator's weight, and weight of heaviest piece part that will be run.

Provide adequate work space around the machine, taking into consideration the largest piece part that will be processed. Keep areas open for access to electrical panel and other maintenance areas.

For best results, operate the lathe in a dry environment that is free from excessive moisture, airborne abrasives, and hazardous chemicals.

Place the machine near an existing power source. Protect the power cord from material handling traffic, and other potential hazards.



## LIFTING AND MOVING THE LATHE

**⚠ WARNING: Serious personal injury or death can occur if safe lifting and moving practices are not followed. Consult the services of a professional rigger if you have any doubts about your lifting equipment capacities or your own abilities.**

1. Unbolt the lathe from the shipping box pallet.
2. Select a suitable location for the lathe that is dry, has adequate lighting, and enough room to be able to service the lathe on all four sides.
3. **Do not try and lift the lathe by the spindle.**

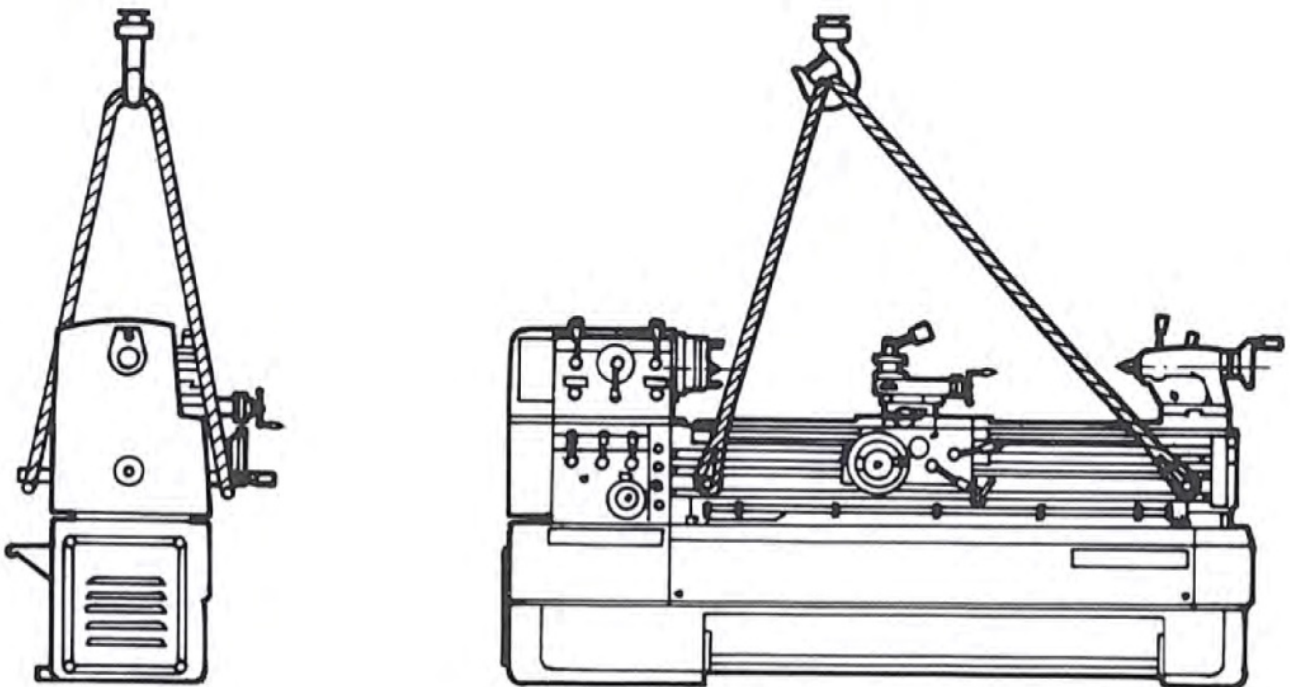
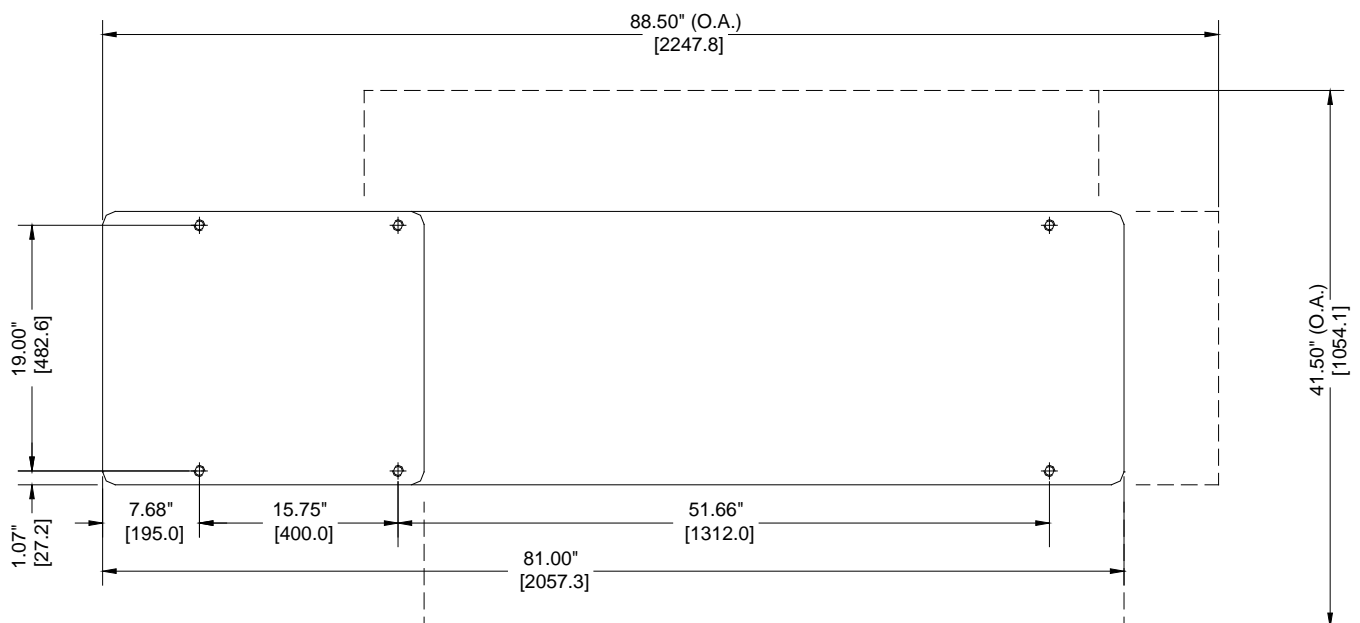

figure 3



4. Use two solid steel bars 1-3/8" (35mm) diameter X 30" (760mm) long (min.) They should extend at least 4" (100mm) on each side of the lathe. Place and steady the bars, then sling as shown in (fig. 3). **NOTE: Make sure that by inserting the steel bars you are not damaging the DRO "Y" axis scale.**
5. If using lift straps to raise the machine, make sure they are in good condition and each one capable of lifting 4,500 lbs. (2,052 kgs.) Make sure the lift straps are routed in such a way as not to damage the lead screw, feed rod, or control rod.
6. Remember. The headstock carries most of the weight of the lathe. Double check the weight ratings and connections before doing the actual lift. Verify that the load is properly balanced by lifting it an inch or two. (25 – 50mm)
7. Avoid any sudden accelerations or change of direction while the lathe is lifted.
8. If you cannot lift the lathe using the two solid steel bars because of an interference issue, you may need to consult an equipment mover for assistance.
9. To avoid any twisting to the bed, make sure the location where the lathe will be set is absolutely flat and level. Use a precision level on the bed ways both front to back and side to side. The leveling pads included in the tool box and the leveling screws in the pockets of the base will help to level the **PL-1640** lathe.

You will be able to obtain more accuracy with a lathe that is level.



**Pedestal Mounting Locations**

tolerance:  $\pm .12$ " on linear dimensions



10. Place machine over (6) foundation bolts (previously located). Machine should be located allowing sufficient area for proper operation and maintenance (chip removal, etc.) Minimum 24" (610mm) from wall at back and tailstock end.

**Level Adjustment**

Once the machine is located on the bolts, a machinists level should be used alternately on the cross slide and slide ways of the lathe as shown in (fig. 5). Minute adjustments of adjusting bolts should be made until the machine is accurately leveled.

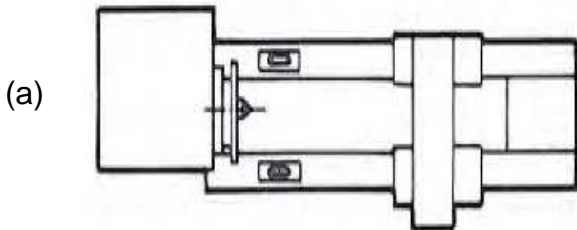

figure 4

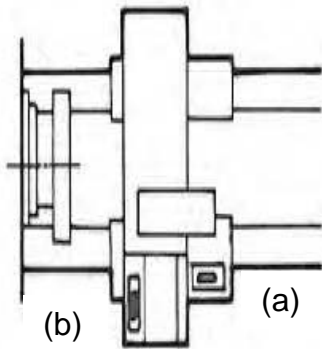
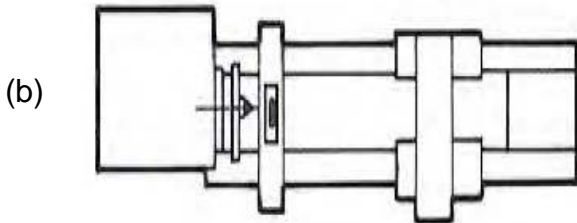

figure 5

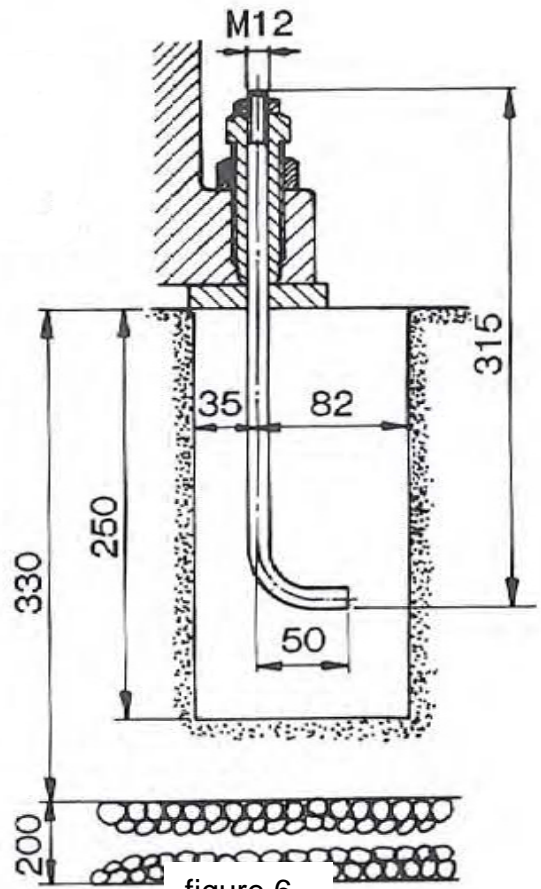

figure 6

(a) Bed Level – Longitudinal Direction

When using precision level along bed, maximum reading to be within 0.0005" in 12" (0.04mm/m)

(b) Bed Level – Transverse Direction

When using precision level, all readings to be within (0.0005" in 12" (0.04mm/m)



## ELECTRICAL

**⚠ CAUTION:** HAVE ELECTRICAL UTILITIES CONNECTED TO MACHINE BY A CERTIFIED ELECTRICIAN!  
Check if the available power supply is the same as listed on the machine nameplate.

**⚠ WARNING:** Make sure the grounding wire (green) is properly connected to avoid electric shock. DO NOT switch the position of the green grounding wire if any electrical plug wires are switched during hookup.

### Motor Specifications

Your machine is wired for 220 volt, 3 ph, 60Hz alternating current. Before connecting the tool to the power source, make sure the machine is cut off from power source.

### Considerations

- Observe local electrical codes when connecting the machine.
- The circuit should be protected with a time delay fuse or circuit breaker with an amperage rating slightly higher than the full load current of machine.
- A separate electrical circuit should be used for your machine. Before connecting the motor to the power line, make sure the switch is in the "OFF" position and be sure that the electric current is of the same characteristics as indicated on the tool.
- All line connections should make good contact. Running on low voltage will damage the motor.
- In the event of a malfunction or breakdown, grounding provides a path of least resistance for electric current to reduce the risk of electric shock. When attaching a cord and plug, the plug must fit a matching outlet that is properly installed and grounded in accordance with all local codes and ordinances.

**⚠ WARNING:** In all cases, make certain the receptacle in question is properly grounded. If you are not sure, have a qualified electrician check the receptacle.

- Improper connection of the equipment-grounding conductor can result in risk of electric shock. The conductor with insulation having an outer surface that is green with or without yellow stripes is the equipment-grounding conductor. If repair or replacement of the electric cord or plug is necessary, **DO NOT** connect the equipment-grounding conductor to a live terminal.



- Check with a qualified electrician or service personnel if the grounding instructions are not completely understood, or if in doubt as to whether the machine is properly grounded.
- Repair or replace damaged or worn cord immediately.

### **Extension Cord Safety**

Extension cord should be in good condition and meet the minimum wire gauge requirements listed below:

AMP RATING	LENGTH		
	25ft	50ft	100ft
0-6	16	16	16
7-10	16	16	14
11-12	16	16	14
13-16	14	12	12
17-20	12	12	10
21-30	10	10	No
WIRE GAUGE			

An undersized cord decreases line voltage, causing loss of power and overheating. All cords should use a ground wire and plug pin. Replace any damaged cords immediately.

### **Power cord connection:**

1. Locate the junction box at the rear of the lathe and remove the cover. (fig. 7)
2. Insert a fitting into the open hole at the bottom of the enclosure to grip the power cord (supplied by customer).
3. Connect the three power wires to the terminals labeled **R**, **S**, and **T**. Connect the ground wire (typically green) to the **E** ground terminal. (Check that the screws are securely tightened.)
4. Inspect the power cord for any damage incurred during installation.

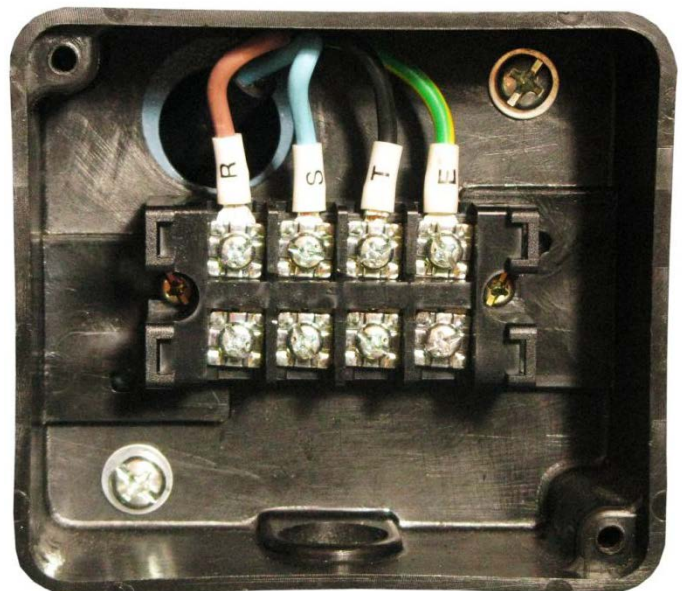

figure 7



## SAFETY FEATURES



Opening the chuck guard will stop machine functions.



Pressing the **E-STOP** (Emergency) button will stop machine functions.



With the gear cover off, the machine will not run.



Stepping on the foot pedal will stop machine functions.





## GETTING TO KNOW YOUR MACHINE

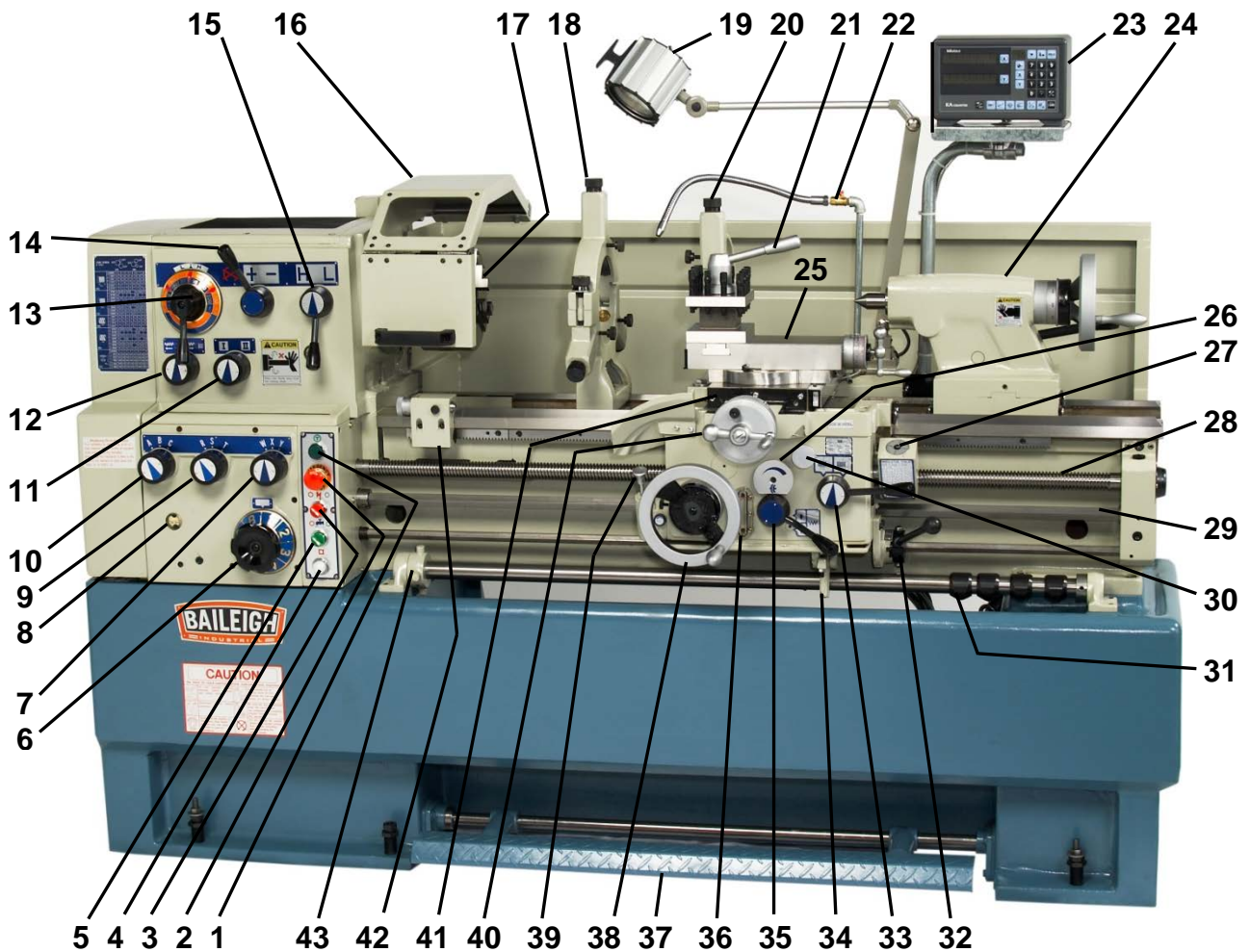

- |                              |                              |                               |
|------------------------------|------------------------------|-------------------------------|
| 1. Jog Button                | 16. Chuck Guard              | 31. Adjustable Trip Dogs      |
| 2. E-Stop Button             | 17. Spindle and Chuck        | 32. Spindle Control Lever     |
| 3. Main Power Switch         | 18. Steady Rest              | 33. Half Nut Engage Lever     |
| 4. Power "ON" Pilot Lamp     | 19. Halogen Work Light       | 34. Trip Arm                  |
| 5. Coolant Power Switch      | 20. Follow Rest              | 35. Feed Engage Lever         |
| 6. Feed Selector Dial        | 21. Tool Post                | 36. Oil Sight Glass           |
| 7. Feed Selection Knob       | 22. Coolant Control Valve    | 37. Brake Pedal               |
| 8. Oil Sight Gauge           | 23. 2 Axis Digital Readout   | 38. Apron Hand Wheel          |
| 9. Feed Selection Knob       | 24. Tailstock                | 39. One-Shot Oiler            |
| 10. Feed Selection Knob      | 25. Compound Rest            | 40. Cross Traverse Handle     |
| 11. Feed I/II Selection Knob | 26. Cone Clutch Adjustor     | 41. Cross Traverse Slide      |
| 12. Feed Direction Knob      | 27. Threading Dial Indicator | 42. Micrometer Saddle Stop    |
| 13. Spindle Speed Lever      | 28. Leadscrew                | 43. Feed Stop Selection Wheel |
| 14. +/- Gear Shift Lever     | 29. Feed Rod                 |                               |
| 15. H/L Gear Shift Lever     | 30. Feed Axis Selector       |                               |



figure 8

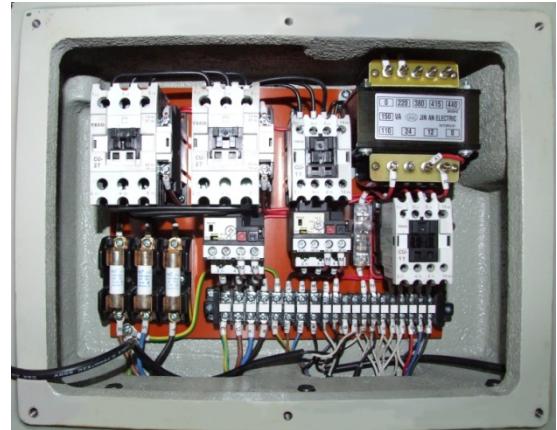

figure 9

Remove (6) screws from the panel shown in (fig. 8) to gain access to the electrical panel.

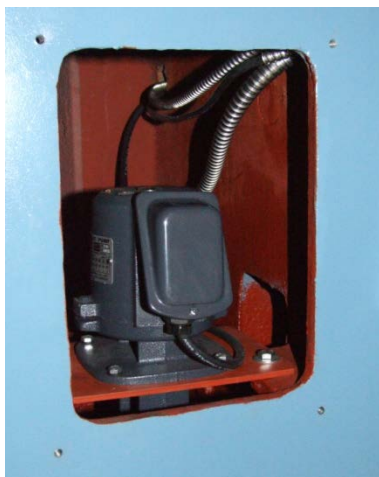

figure 10

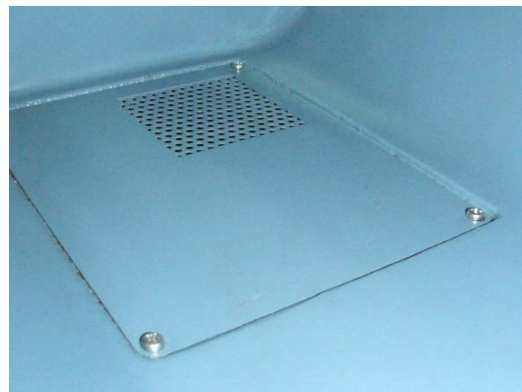

figure 11

Shown in (fig. 10) is the 1/8 Hp coolant pump. Remove the panel for access to the pump. (Fig. 11) shows the screen panel that can be removed to get access to the coolant sump.



figure 12 – Brake with switch



figure 13 – Chuck guard switch



### Steady Rest

The steady rest on the **PL-1640** lathe is used to support long, small diameter stock that otherwise could not be turned. The steady rest can also be used in place of the tailstock when access to the cutting tool is required at the outboard end of the piece part. By loosening the nut in the base, the steady rest can be re-positioned along the slide rails.



figure 14

### Follow Rest

The follow rest is typically used for small diameter stock to prevent the piece part from “springing” under pressure from the tool. The follow rests, which are opposite the tool post, act as supports to counter balance the force exerted on the piece part by the tool. The tool and the supports form a triangle around the part to help minimize vibration. The follow rest has two adjustable brass points to allow rotation of jobs without causing abrasive scratches. The soft points will need replacement when they wear out.



figure 15



## Dead Center

A dead center is a one-piece center that does not rotate with the component it is mounted into. It is used to support long, slender piece parts. Use the dead center when the piece part does not rotate on the tip and does not generate friction.



**WARNING** When using a center in the spindle to mount a piece part, the other end of the piece part **MUST** be supported by a center installed in the tailstock quill to safely hold the piece part in place during operation. Otherwise the piece part can be ejected from the lathe when the spindle rotates. This could cause serious personal injury or property damage.

**Note:** To avoid wearing out the dead center prematurely or damaging the piece part, use low spindle speeds. Also keep the tip of the dead center mounted in the tailstock well lubricated with an anti-sieze compound.

## Tailstock

The tailstock consists of the base and the base lock handle, barrel and the barrel lock handle, hand wheel, body, and screw. The tailstock on a lathe has many functions including supporting the piece part opposite the headstock. It also has a barrel imprinted with graduations in millimeters and inches and a #3 Morse taper for securing drill bits, and centers. The tailstock can be easily set or adjusted for alignment or non-alignment with respect to the center of the spindle. By turning the tailstock handwheel you can advance or retract the barrel in the tailstock. Both live and dead centers have 60° conical points to fit center holes in the end of the cylindrical piece part.

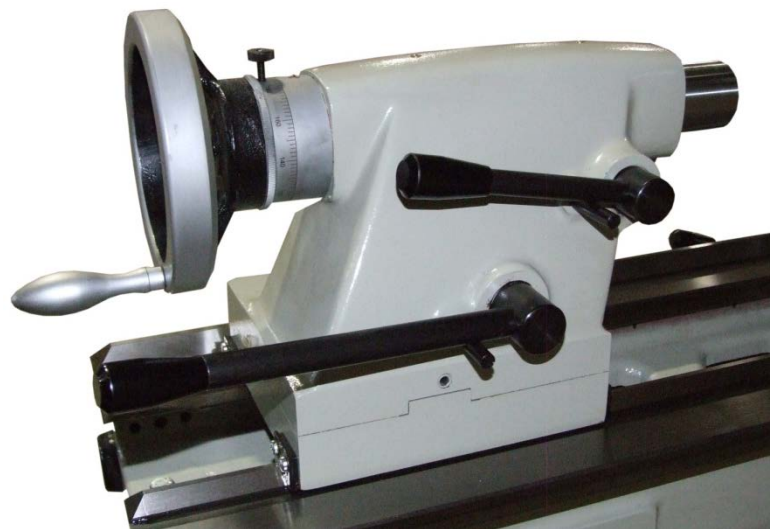

figure 16

When mounting a long slender piece part that extends more than 2-1/2 times its diameter beyond the jaws of the chuck, mount a center in the tailstock to support it.



- 1) Before mounting a piece part onto the tailstock dead center, **DISCONNECT POWER TO THE LATHE.**
- 2) Thoroughly clean and dry the tapered surfaces of the tailstock quill bore and the point of the dead center. Apply a thin coat of light weight machine oil to the surfaces and wipe again to leave a minimal amount of oil on the mating surfaces.
- 3) Using the tailstock hand wheel, feed the quill out from the casting at least 1" but not more than 2".
- 4) Center drill the tailstock end of the piece part to match the tip of the dead center. This will help keep the piece part from slipping off the center tip.
- 5) Seat the dead center into the quill and position the tailstock so that the tip of the center presses against the piece part to hold it in place. Tighten the tailstock lock lever.
- 6) Rotate the tailstock hand wheel clockwise (**cw**) to press the center into the piece part until snug. Tighten the quill lock lever.
- 7) To remove the dead center from the quill, hold onto it with one hand and rotate the hand wheel counterclockwise (**ccw**) until the center falls out.

### Quick Change Tool Posts

The **PL-1640** comes with a quick change four-way tool post. It is mounted on top of the compound slide and can be loaded with a maximum of four tools. Use a minimum of two bolts to secure the tooling.

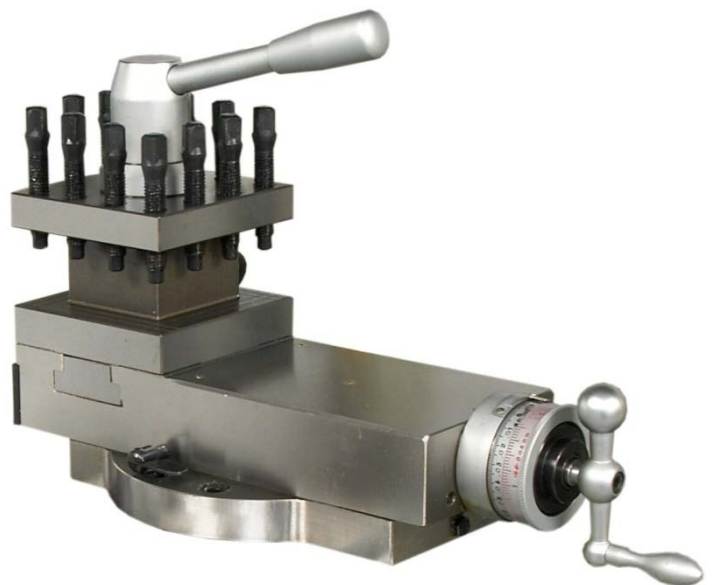

figure 17



## LATHE SETUP



### WARNING

**DO NOT** start the lathe until all machine assembly has been completed and you have been properly trained and understand all control functions. When performing machine assembly make sure to follow proper lockout / tagout procedures. Failure to comply could result in accidental starting of the lathe resulting in **SERIOUS OPERATOR INJURY OR DEATH.**

Lubrication (Before operating the **PL-1640** lathe make the following important checks.)

1. Fill the headstock to the level as indicated in the sight gauge window (1) with Shell Tellus #32 viscosity oil (or equivalent).
2. Fill the gearbox to the level as indicated in the sight gauge window (2) with Shell Tellus #68 viscosity oil (or equivalent).
3. Fill the carriage apron to the level as indicated in the sight gauge window (3) with Shell Tellus #68 viscosity oil (or equivalent).

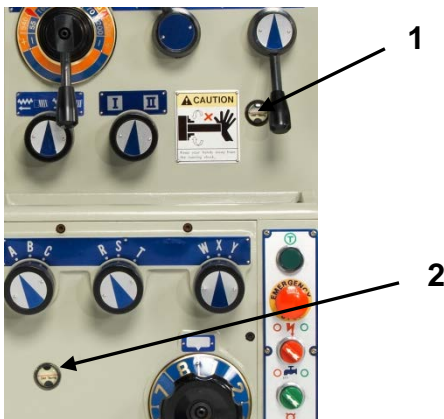

figure 18

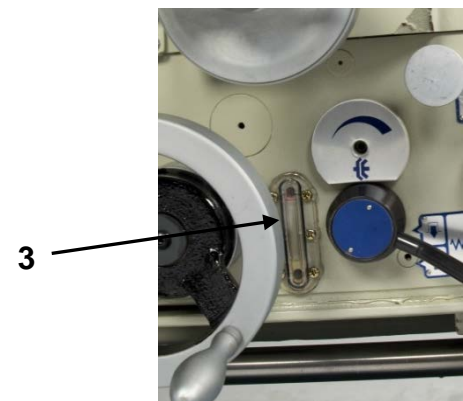

figure 19

### Chuck

The **PL-1640** metal lathe has an 8" (203mm) 3-jaw chuck already installed. This is a scroll- type chuck which means that all three jaws close together and are self-centering.

The 3-jaw chuck has Cam lock mounting. Note that there are lines stamped on the cam and on the chuck (fig. 20). These indicate whether the cam is in a locked position or an unlocked position where the chuck can be removed.

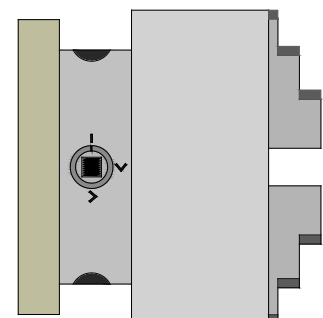

figure 20



A chuck key is used to turn the locking cams as shown in (fig. 21).



## WARNING

**NEVER** leave a chuck key in the chuck if the machine is not in use. If the lathe is accidentally started with the key in place, it can become a projectile and cause serious **INJURY OR DEATH**.



figure 21

### To Remove a Chuck

- 1) Lay a piece of plywood on the lathe bed directly beneath the chuck. This will help protect the ways if the chuck should fall.



**CAUTION:** Use extreme care when installing or removing a chuck so that your hands do not become trapped between the chuck and the plywood.

- 2) Turn the first cam counterclockwise (**ccw**) using the chuck key until the line on the cam is aligned with the line on the spindle housing as shown in (fig. 22).
- 3) Rotate the spindle housing to access the remaining cams and turn each one counterclockwise (**ccw**) until the marks are aligned. Make sure to support the chuck with one hand as you turn the last cam. You should now be able to remove the chuck.
- 4) If the chuck is still tight on the spindle, tap the back of the chuck with a wooden or rubber mallet while supporting the bottom of the chuck with your other hand. If needed, rotate the chuck a bit, and tap again. Make sure all the marks on the cams and spindle are properly aligned.

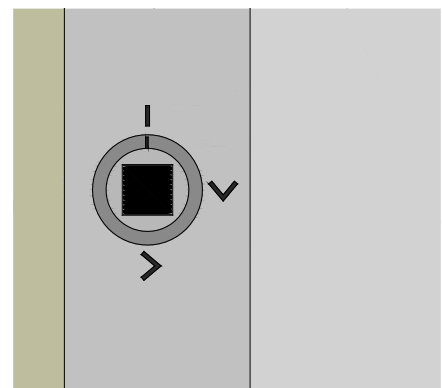

figure 22



### To Install a Chuck

- 1) Lay a piece of plywood on the lathe bed directly beneath the spindle housing. This will help protect the ways if the chuck should fall.
- 2) Lift the chuck up to the spindle and insert the camlock pins into the face of the spindle.
- 3) While supporting the weight of the chuck, use the chuck key to turn one of the cams until the cam line is between the two "V" marks on the spindle as shown in (fig. 23).
- 4) Rotate the spindle and repeat step 3 for the rest of the cams.
- 5) Starting with the first cam, snug up the cams.
- 6) Finally go around and tighten all of the cams.

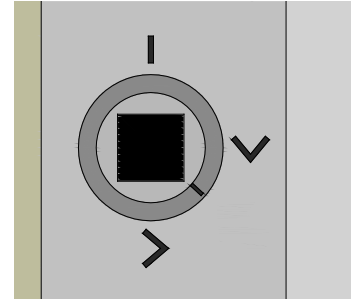

figure 23

### To Install Cam lock Studs

- 1) Lay the chuck or faceplate upside down on a flat protected surface.
- 2) Screw in the three studs up to the depth mark as indicated in photo below.
- 3) Once the studs are properly positioned, secure them with the socket head cap screws.
- 4) To adjust the cam lock studs, remove the cap screw and rotate the stud 1 full turn in or out. Re-insert the cap screw and tighten.



figure 24

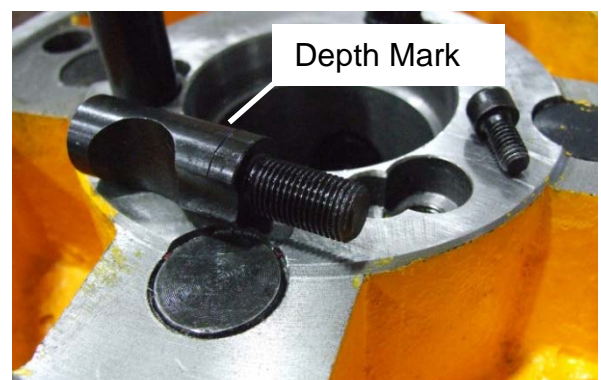

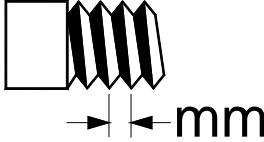

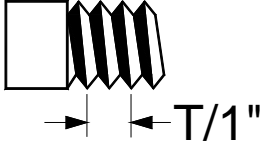



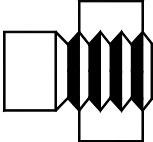
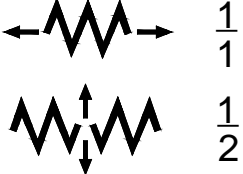
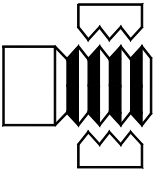
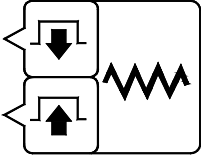

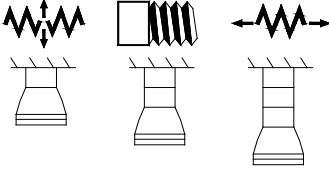

figure 25



### Symbols for Operation

	<p>Switch is on as long as button is pressed (Intermittent)</p>		<p>Metric Thread</p>
	<p>Electrical (DANGER)</p>		<p>Imperial thread</p>
	<p>Pilot Lamp</p>		<p>Module pitch thread</p>
 <p>RED GREEN</p>	<p>Coolant Green: ON Red: OFF</p>		<p>Diametral pitch thread</p>
	<p>Half nut closed</p>		<p>Longitudinal feeds <math>\frac{1}{1}</math> Cross feeds half longitudinal values <math>\frac{1}{2}</math></p>
	<p>Half nut open</p>		<p>Engaged (Downward) Feed Disengaged (Upward)</p>
	<p>Do Not change speed while machine is running.</p>	 <p>Cross feed can be obtained by pushing in the knob (The first line). Thread cutting can be obtained by keeping the knob in neutral position (The second line). Longitudinal feed can be obtained by pulling out the knob (The third line).</p>	



	<p>Right hand thread and longitudinal feed towards the headstock side.</p>		
	<p>Left hand thread and longitudinal feed towards the tailstock side.</p>		
<p>mm / </p> <p>ins / </p>	<p>Auto feed per revolution in Metric.</p> <p>Auto feed per revolution in Imperial.</p>		
	<p>Lube pump; push button</p>		
	<p>Cone clutch; adjust clockwise</p>		
	<p>Main spindle reverse rotation (clockwise rotation; looking from tailstock)</p>		
	<p>Main spindle forward rotation (counterclockwise rotation; looking from tailstock)</p>		
	<p>Lube flow, adjust counterclockwise</p>		<p>Emergency Stop</p>



### Coolant System

The coolant system delivers the coolant to the nozzle which can be positioned where needed. The coolant pump is energized by turning on a two position switch as shown in (fig. at right) and the flow is controlled with the valve lever.

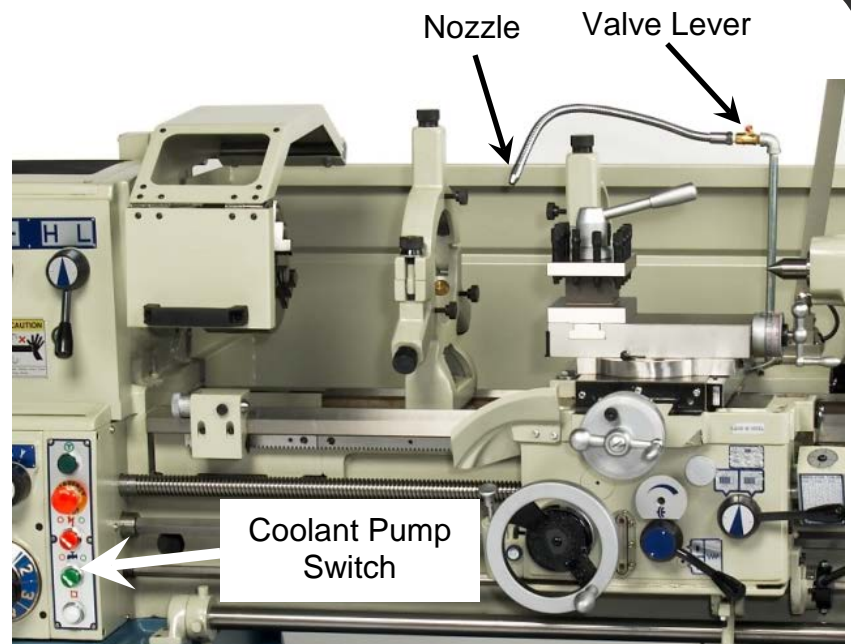

figure 26

### OPERATING CONTROLS

- Pressing button (1) will jog the spindle to allow the feed selection knobs to engage at their desired position.
- Pressing the **E-STOP** button (2) will immediately stop the machine in the event of incorrect operation or a dangerous situation. Twist the emergency stop button clockwise (**cw**) to reset.
- Selector switch (3) when turned clockwise (**cw**) will supply power to the entire lathe.
- The two position coolant switch (4) is used to **START** or **STOP** the coolant pump.
- The white pilot light (5) when lit, indicates that the power selector switch has been turned to the **ON** position and the machine has power.

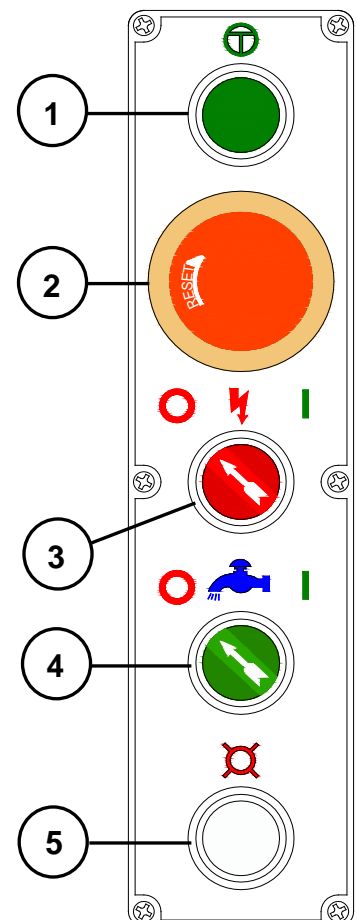

figure 27



**CAUTION:** Never change spindle speeds while the motor or spindle is in motion.

### Spindle Speeds

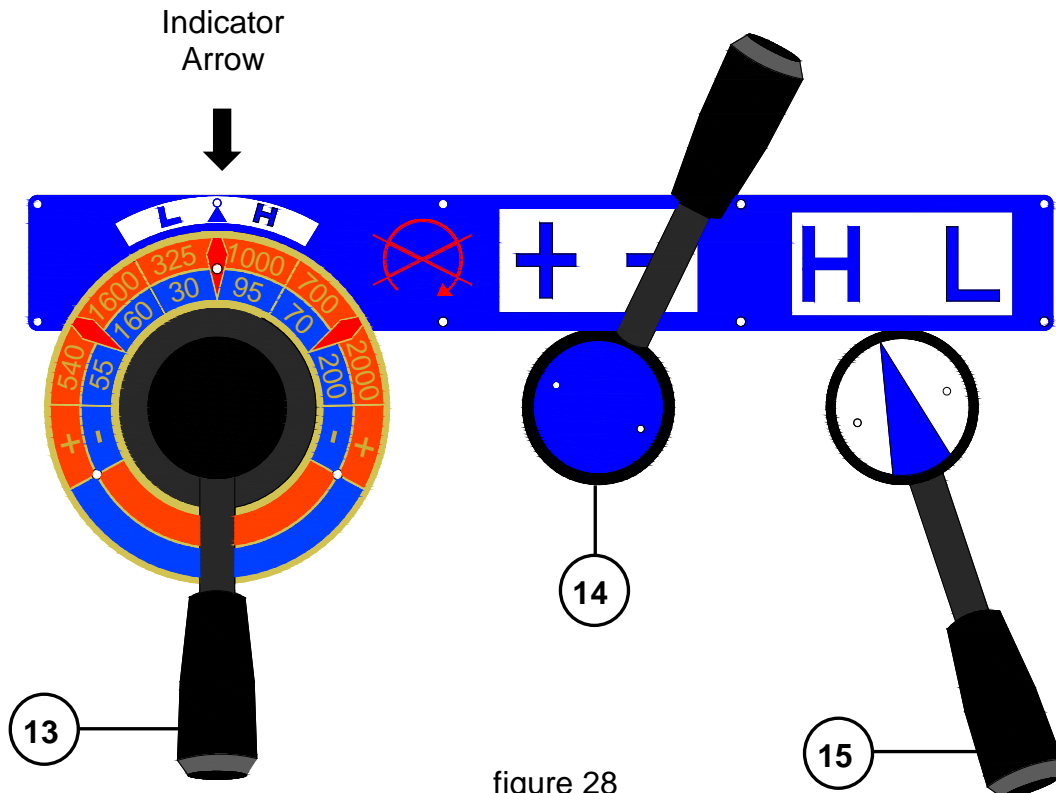

figure 28

The speed of the spindle is set by the position of the three speed control handles as shown in (fig. 28). As an example they will be set for a speed of 95 RPMs. The selector handle (13) is rotated to the center position. Each of the three positions will click when the handle is properly rotated. The 95 RPM selection is in the blue area, so selection handle (14) should be in the minus (-) position as shown. To the right of the indicator arrow is the 95 RPM value. The (H) indicates high speed, whereas the 30 RPM value would be the low (L) speed setting. The selector handle (15) is therefore set to (H) for high speed. Spindle speed is measured in RPM (revolutions per minute). The following 12 spindle speeds are possible on the PL-1640 lathe: **30, 55, 70, 95, 160, 200, 325, 540, 700, 1000, 1600, and 2000 RPM.**



**Note:** If any of the 3 handles offer resistance when shifting, briefly press the jog button (1) in (fig. 27) to line up the gears and allow the handle to shift.



## Feed Direction



**CAUTION:** Never change spindle speeds while the motor or spindle is in motion.

The **PL-1640** lathe can cut both left and right while feeding or threading, and across the ways when performing facing operations. The feed direction is controlled with the selection knob (12) as shown in (fig. 29). When rotated to the left position the apron will move to the left along the bed, as indicated by the arrow, or the cross feed will travel away from the operator.

Rotating the handle to the right will reverse the direction of the feeding or threading.

The quick relieving and smooth fine feeding (quick change over from roughing to fine feeding) can be obtained by operating the two step feed change gears as explained below:

1. Stop the spindle by putting the spindle control lever (32) into **NEUTRAL** stop position.
2. a. Rotate the feed I /II selection knob (11) from position I to II for quick relieving (rough feed).  
b. Rotate the feed I / II selection knob (11) from position II to I for smooth fine feeding.
3. Start the spindle by putting the spindle control lever in either the forward or reverse position.

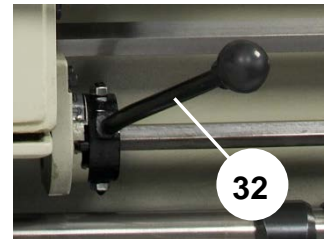

**NOTE:** Never force any of the selection handles or knobs on the lathe. If a handle will not engage, rotate the chuck carefully using the jog button (1), while applying light pressure to the selector handle or knob. As the chuck rotates, the gears will align, allowing the selector handle or knob to engage.

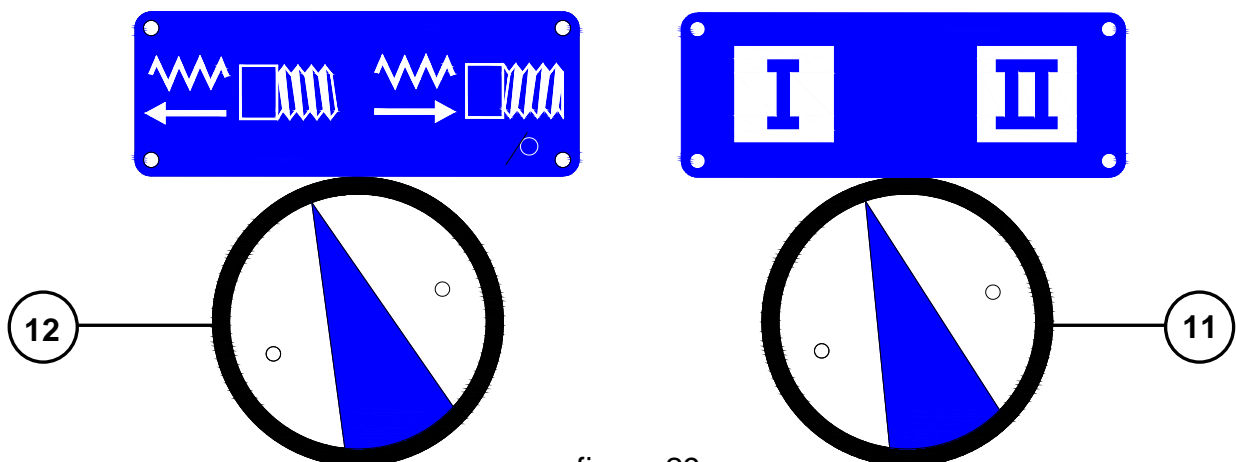

figure 29



## Feed Selector Knobs

The three knobs as shown in (fig. 30) are used to change the feed rate or number of threads-per-inch. This part of the lathe is commonly referred to as the Quick Change Gear Box. It has been designed to handle both inch (imperial) and metric (mm). The knob on the left (10) **A, B, & C**, the center knob (9) **R, S, & T**, and the right knob (7) **W, X, & Y** are set to a selected value from the chart on the following page. The feed selector dial (6) will be set to a numerical value from the chart. (This chart is also located on the front of the headstock gear cover.)

**CAUTION: DO NOT SHIFT QUICK CHANGE GEARS AT SPEEDS ABOVE 325 RPM.**

### Important:

Do not force the selection knobs into position. If they do not engage, carefully rotate the chuck by pressing the jog button (1). As the chuck is rotated, it aligns the gears, and the selector knob will engage.

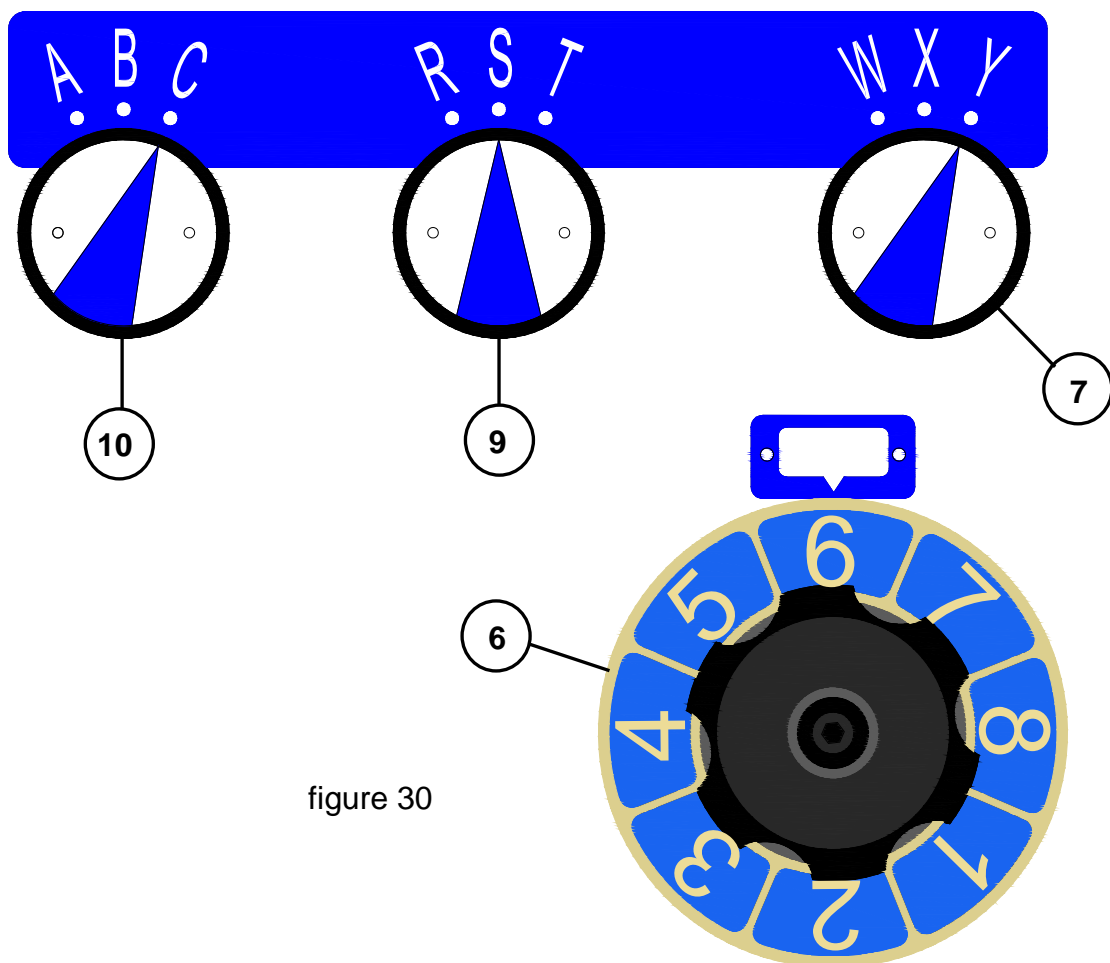

figure 30



**Thread Cutting and Feed Chart**

figure 31

As an example, 24 threads per inch has been selected as shown in red.

The change gears (V) will be 24T, 57T, and 64T.

The areas in yellow will be the settings of the knobs as shown below.

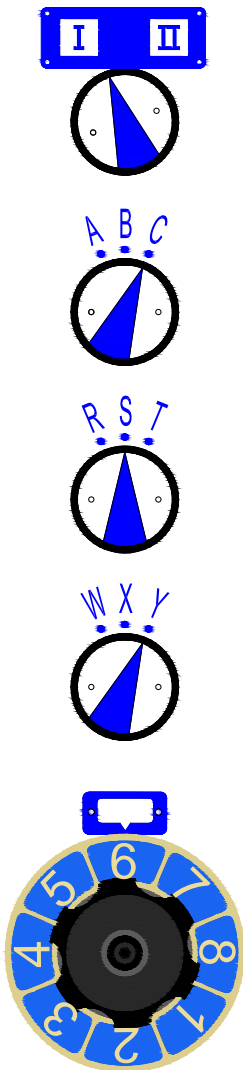

figure 32

LEAD SCREW 64T 4 T.P.I.

Change gears (V): 24T, 57T, 64T

Change gears (W): 41T, 31T

	LEVER	1	2	3	4	5	6	7	8	
	I CRY	32	36	40	44	46	48	52	56	
	<b>I CSY</b>	16	18	20	22	23	24	26	28	
	I CTY	8	9	10	11	11½	12	13	14	
	II CSY	4	4½	5	5½	5¾	6	6½	7	
	II CTY	2	2¼	2½	2¾	2⅞	3	3¼	3½	
	(V)									
	I ATW	0.4	0.45	0.5	0.55		0.6	0.65	0.7	
	I BTW	0.5					0.75			
	I ASW	0.8	0.9	1.0	1.1	1.15	1.2	1.3	1.4	
	I BSW	1.0		1.25			1.5		1.75	
	I ARW	1.6	1.8	2.0	2.2	2.3	2.4	2.6	2.8	
	I BRW	2.0	2.25	2.5	2.75		3.0	3.25	3.5	
	II BSW	4.0	4.5	5.0	5.5	5.75	6.0	6.5	7.0	
	II BRW	8.0	9.0	10	11	11.5	12	13	14	
	(V)									
		I CRY	32	36	40	44	46	48	52	56
I CSY		16	18	20	22	23	24	26	28	
I CTY		8	9	10	11	11½	12	13	14	
II CSY		4	4½	5	5½	5¾	6	6½	7	
(W)										
		I ATW	0.4	0.45	0.5	0.55		0.6	0.65	0.7
	I BTW	0.5					0.65			
	I ASW	0.8	0.9	1.0	1.1	1.15	1.2	1.3	1.4	
	I BSW	1.0		1.25			1.5		1.75	
	I ARW	1.6	1.8	2.0	2.2	2.3	2.4	2.6	2.8	
	I BRW	2.0	2.25	2.5	2.75		3.0	3.25	3.5	
	II BSW	4.0	4.5	5.0	5.5	5.75	6.0	6.5	7.0	
	(W)									
		LEVER	1	2	3	4	5	6	7	8
		I ATX	.0012	.0014	.0015	.0016	.0017	.0018	.0020	.0022
I ASX		.0024	.0028	.0030	.0032	.0034	.0036	.0040	.0044	
I ARX		.0048	.0056	.0060	.0064	.0068	.0072	.0080	.0088	
II ASX		.0096	.0112	.0120	.0128	.0136	.0144	.0160	.0176	
II ARX		.0192	.0224	.0240	.0256	.0272	.0288	.0320	.0252	



## Thread Cutting and Feed Chart

All threads and feeds available on the **PL-1640** lathe are displayed in the chart on the previous page and on the front of the headstock gear cover.)

To obtain the desired thread or feed required, all change gears must be correctly installed as shown in this chart. The **PL-1640** can be set to the following thread sizes and feeds:

### Threads:

**40** Imperial pitches from 2 to 56 T.P.I. (threads per inch) – (see chart on following page)

**52** Metric pitches from 0.4 to 14mm – (see chart on following page).

**32** Diametral pitches from 4 to 32 D.P. (diametral pitch) – (see chart on following page)

**44** Module pitches from 0.4 to 7 M.P. (module pitch) – (see chart on following page)

### Feeds: longitudinal

**40** Imperial from .0012" to .0252" / rev. (with 4 T.P.I. lead screw)

**40** Metric from 0.032 to .640mm / rev. (with 6mm lead screw)

### Feeds: Crossfeeds (1/2 of the longitudinal feed)

**40** Imperial from .0006" to .0126" / rev. (with 4 T.P.I. lead screw)

**40** Metric from .015 to .320mm / rev. (with metric lead screw)



## Thread Cutting Operation

### 1. Feed:

- Set the desired feed rate (from chart on front of gear cover)
- With spindle running at desired RPM, engage the feed lever (35) on the apron.

*The distance the saddle travels during one revolution of the spindle is called feed and will be established as explained above.*

### 2. Thread pitch / lead:

- Set desired pitch (lead), T.P.I. (threads per inch)
- With spindle running at the desired RPM, engage the half nut lever (33).

*The distance the saddle travels during one revolution of the spindle is called lead or pitch. The number of revolutions the spindle makes while the saddle (tool) travels 1" (25.4mm) is equal to T.P.I. (threads per inch)*

Remarks: In normal turning / facing operations it is recommended that the "lead screw" be disengaged to avoid any possible wear.

## APRON

The apron houses controls for automatic feeding and threading with a positive interlock between the two to prevent simultaneous engagement. It provides an oil reservoir to supply oil to all of it's moving parts. It also has a "one shot" oiler pump (39) to distribute lubricant to the saddle ways that contact the bed ways and cross slide ways.

**Feeds – manual:** The apron hand wheel (38) may be used to traverse the saddle left or right (longitudinal) either in a rapid motion or as a slow manual feed mechanism.

**Feeds – power:** Either longitudinal or cross travel are selected by positioning the feed axis selector (30) "IN" (on the first line) for cross feed or "OUT" (on the third line) for longitudinal feed. (fig. 33) To engage the feed; (once direction has been established) push feed engage lever (35) downward until fully engaged (fig. 34). To dis-engage, lift feed engage lever (35).

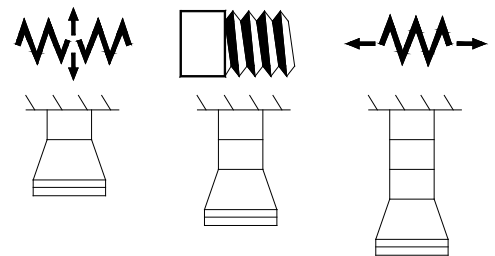

figure 33

**Cone Clutch** - The cone clutch adjustor (26) is a safety overload clutch mechanism for the feed system. The adjustment screw increases or decreases the clutch pressure. (See *Adjustment Section in this manual.*)

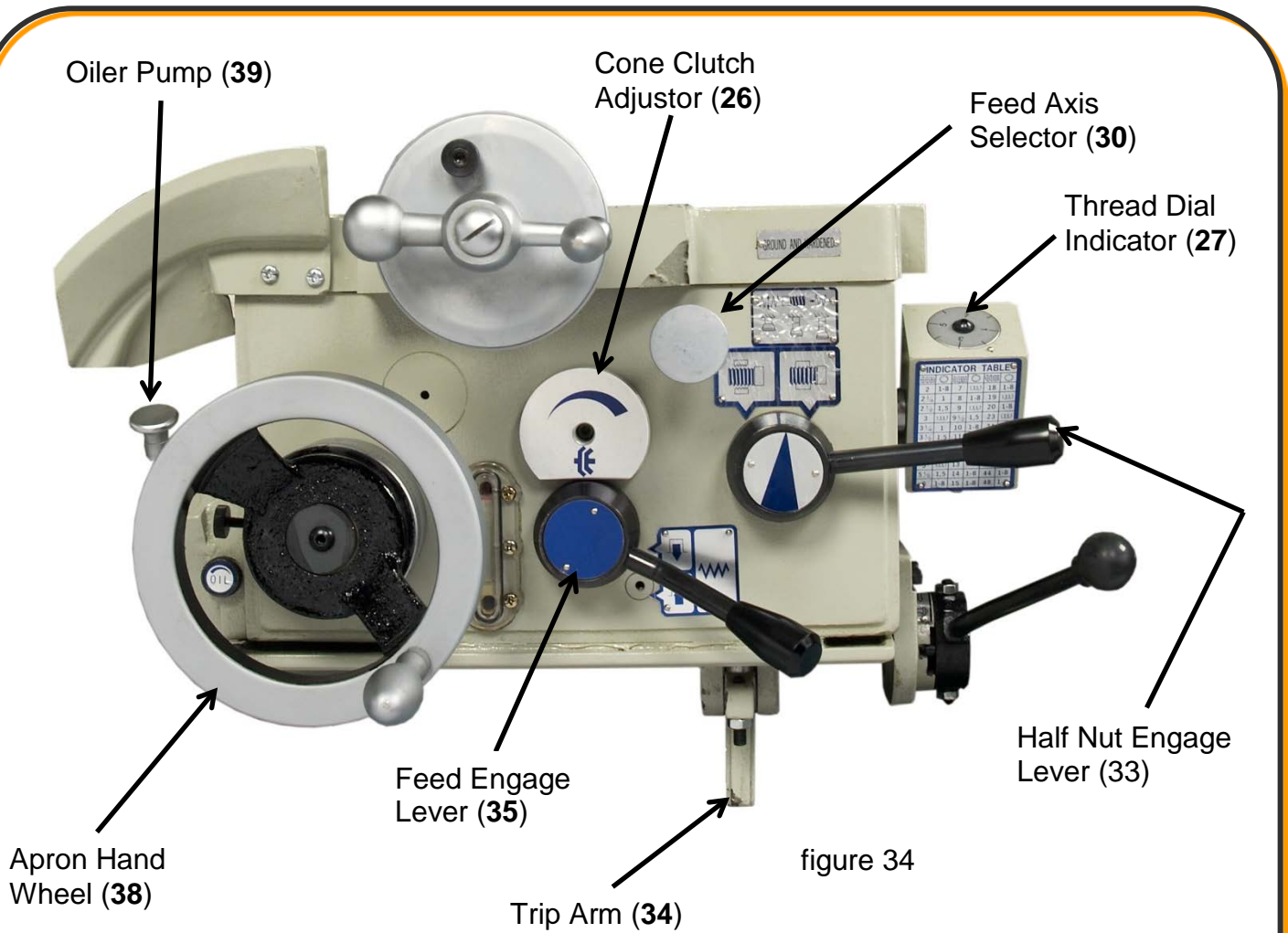

figure 34

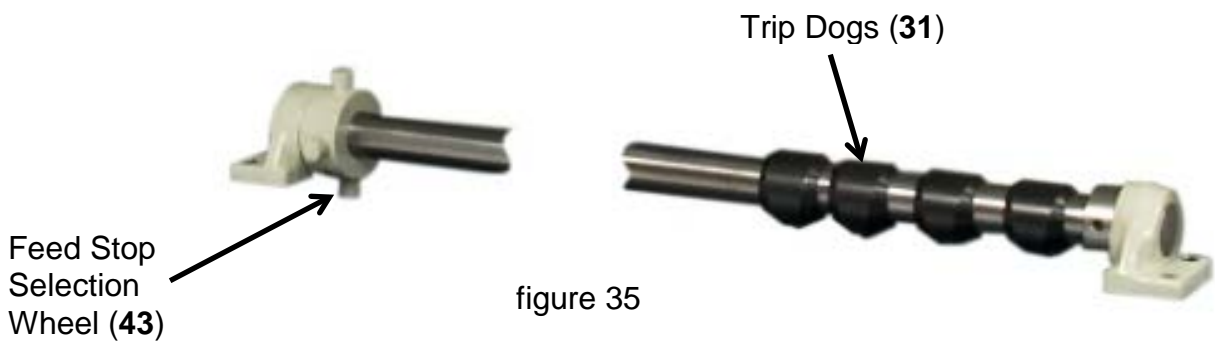

figure 35

**Feed Disengagement** – The automatic feed disengagement system operates when the adjustable trip dogs (31) come in contact with the trip arm (34) as the apron is moving longitudinally. The four trip dogs are controlled / engaged by rotating the dogs to the frontward position with the selection wheel (43) located at the headstock end of the rod.



### Threading

The half nut engagement lever (33) engages / disengages the half nut and lead screw. The feed axis selector (30) must be in neutral (on the second line) in order to engage the half nut. The spindle should be rotating at a relatively low speed to properly engage the half nut, especially for coarse threads.

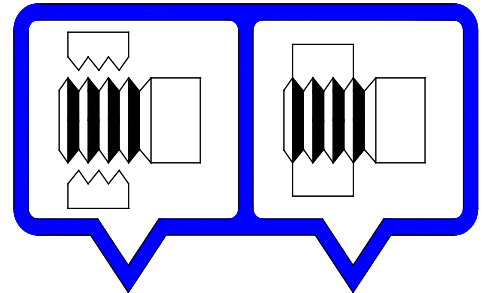

figure 36

### Thread Dial Indicator

The threading dial indicator (27) shown in (fig. 37) is located on the right hand side of the apron. It is used when cutting imperial threads and tells you when to engage the half nut to begin the threading process. The indicator face has eight lines and four numbers printed on the dial. An indicator pin is located at the bottom of the rim. The dial is mounted to a shaft that has a small gear mounted at the opposite end. By loosening a socket capscrew you can pivot the housing to either engage or disengage from the leadscrew. When engaged, the dial will turn as the spindle rotates. If the dial does not turn, re-adjust the housing position.

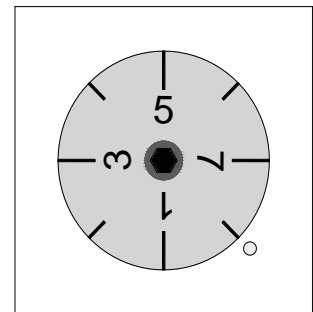

figure 37

When the half nut is disengaged the dial stops turning. By carefully engaging the half nut as the correct number or line passes by the indicator mark, a thread can be established and the lead maintained through multiple passes, until the required depth is reached.

As an example, to cut 20 threads per inch using the chart in (fig. 38), engage the half nut on any number or line at the indicator mark. You must determine how long you want the thread to be. When you reach that length, disengage the half nut. Return the carriage to the beginning of the cut. Watch the dial and when any number or line comes around to the indicator mark, engage the half nut. Repeat the procedure until you have reached the desired depth of thread required.

The other scale values from the chart are as follows:

- 1 = Engage only on 1
- 1,5 = Engage on 1 or 5
- 1,3,5,7 = Engage on 1,3,5, or 7
- 1 – 8 = Engage on any number or line

INDICATOR TABLE					
2	1-8	7	1,3,5,7	18	1-8
2¼	1	8	1-8	19	1,3,5,7
2½	1,5	9	1,3,5,7	20	1-8
3	1,3,5,7	9½	1,5	23	1,3,5,7
3¼	1	10	1-8	24	1-8
3½	1,5	11	1,3,5,7	28	1-8
4	1-8	11½	1,5	32	1-8
4½	1,5	12	1-8	36	1-8
5	1,3,5,7	13	1,3,5,7	40	1-8
5½	1,5	14	1-8	44	1-8
6	1-8	15	1-8	48	1-8

figure 38



## **⚠ WARNING**

Before powering up machine, make sure Fwd/Rev. handle is in the center (neutral) position. (See fig. 39)

All machinery poses a potential for danger when being operated. Accidents result from lack of machine knowledge and failure to pay attention. Always be cautious and alert to the potential for serious injury. Follow safety rules and precautions to lessen the chances of an accident.

### **Spindle Rotation Control**

Spindle rotation is controlled from the handle on the right hand side of the apron as indicated in (fig. 39). Move the handle down and the spindle will rotate in a counterclockwise (**ccw**) direction. Move the handle up and the spindle will rotate in a clockwise (**cw**) direction. The middle (**neutral**) position stops the motor.

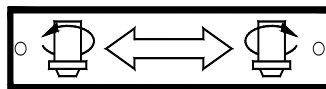

Pin will engage hole when  
In neutral position.

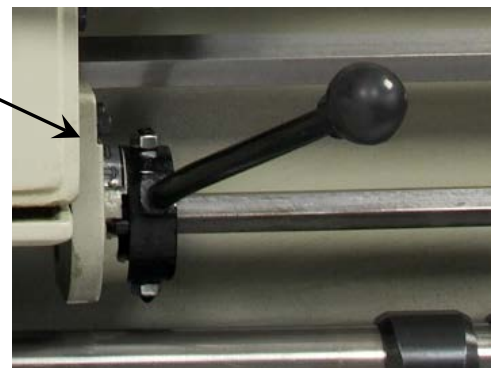

figure 39

### **Micrometer Saddle Stop**

The saddle stop (fig. 40) can be locked to the carriage rail at any point where you want the carriage to stop by tightening the two socket cap screws indicated by the arrows. The saddle stop is used primarily for turning, facing, or boring duplicate parts, as it eliminates taking repeated measurements of the same dimension. To use the stop, just before the carriage reaches the stopping point, shut off the automatic feed and manually run the carriage up against the stop. Use the knob to accurately set the required distance in millimeters. Use the thumbwheel knob to lock the barrel in position.

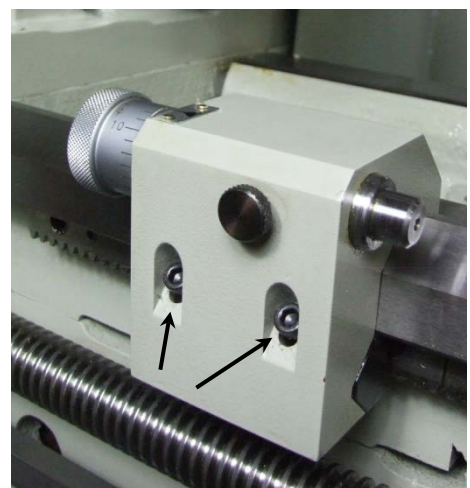

figure 40



### Saddle – cross slide and compound rest

The lathe saddle is solidly supported and accurately guided by the “V” bedway in the front and the flat bedway at the rear. Large “dovetail” ways support and guide both the cross traverse slide (41) and top slide/compound rest (25) to offer smooth movement and solid support for the tool.

Manual Operation:

The carriage (saddle) can be moved manually (longitudinally) either left or right by turning the apron hand wheel (38). To manually feed, a slow even motion is required.

**(NOTE: FEED AXIS SELECTOR (30) MUST BE IN THE NEUTRAL POSITION).**

Powered Operation:

The carriage can be power feed longitudinally at various feed rates selected at the quick change gearbox.

**⚠ CAUTION: Before engaging power feed, make sure the carriage locking bolt has been loosened sufficiently to allow the carriage to move freely.**

The locking bolt is indicated with the arrow in (fig. 41).

- 1) Establish the required feed rate at the quick change gear box.
- 2) Determine the direction of feed using the feed direction selection knob (12) located at the headstock.
- 3) Pull feed axis selector (30) to the “OUT” position (the third line) for longitudinal power feed (fig. 33).
- 4) Engage feed: Move feed engage handle (35) to the “DOWN” position.
- 5) To stop: Raise feed engage lever (35) to the disengaged “UP” position.

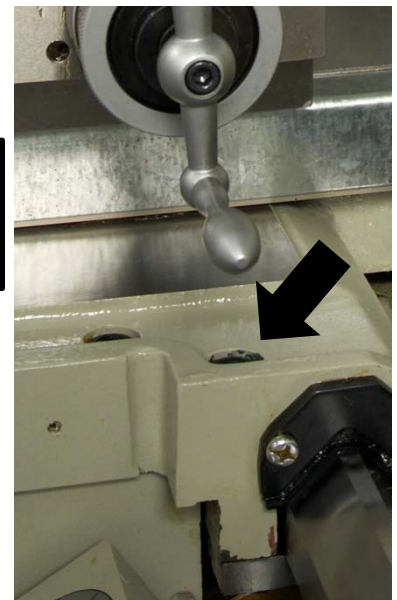

figure 41

### Cross Traverse Slide

The cross slide (41) shown in (fig. 42) can also be operated either manually or under power.

Manual Operation:

- 1) Place feed axis selector (30) in neutral (the second line position).
- 2) Turn cross traverse handle (40) in desired direction. Distance moved can be read on the micrometer dial.



### Powered Operation:

- 1) Establish the desired feed rate at the quick change gear box. **Note:** Cross feeds equal half of the longitudinal values.
- 2) Determine the direction of feed using the feed direction selection knob (12) located at the headstock.
- 3) Push feed axis selector (30) to the "IN" position (the first line) (fig. 33).
- 4) Engage feed: Move feed engage handle (35) to the "DOWN" position.
- 5) To stop: Raise feed engage lever (35) to the disengaged "UP" position.

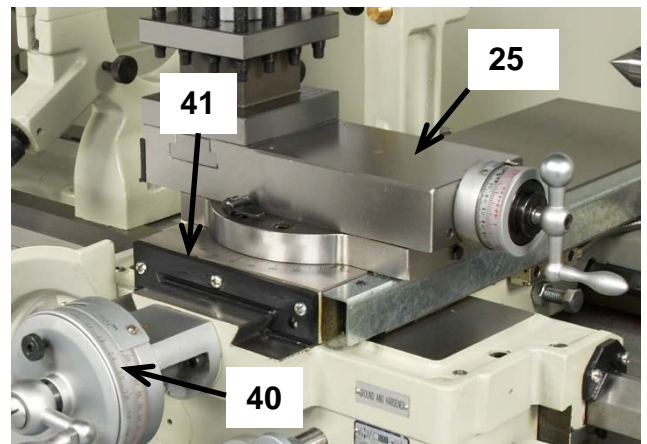

figure 42

### Compound Rest

The compound rest (25) can only be operated manually. It is mounted on a swivel base that enables it to be mounted at any desired angle after loosening four socket head bolts.

**CAUTION: DO NOT OPERATE COMPOUND REST UNLESS LOCK SCREW HAS BEEN RELEASED.**



Lock  
Screw

figure 43



**WARNING:** Attempting heavy cuts while the compound rest is extended beyond the end of the base sideways can result in **SERIOUS OPERATOR INJURY.**

### Half Nut

The half nut is exactly what the term implies; "a nut separated in two pieces" lengthwise. The two half nut pieces are mounted to the apron body in such a way that they can be mechanically separated or brought around the lead screw threads (engaged – disengaged) When the lead screw is rotating, engaging the half nut will cause the apron / carriage to move at the rate determined by the gear ratio set at the quick change gear box. This will then move the tool at the proper rate to cut threads.

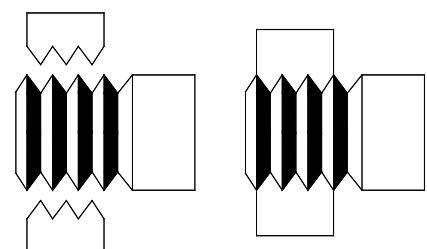

figure 44



A positive lockout device is provided to prevent the accidental engagement of two opposing feeds simultaneously. **(THE FEED ENGAGE LEVER CANNOT BE ENGAGED WHEN THE HALF NUT IS ENGAGED)** Lead screw and half nut life is dependent on three basic conditions.

- 1) The lead screw and half nut must be clean (no grit or chips)
- 2) The lead screw and half nut must be properly lubricated.
- 3) The lead screw and half nut must be properly adjusted to engage evenly and smoothly.

### Lead Screw

The 1-3/8" (35mm) diameter lead screw is designed to provide accurate threading capability and long service life. It is protected from overloading by a shear pin. It should be further protected from unnecessary wear by being disengaged from the thread dial indicator when not in use. It is imperative that the lead screw be clean and properly lubricated while threading. In order to obtain maximum accuracy, it is necessary to keep all end play out of the lead screw and the half nut. The lead screw is mounted in adjustable ball thrust bearings so that a "NO FLOAT" condition can be maintained.

### Changing Gears for Thread Selection

In order to cut threads and set longitudinal feed and crossfeed rates as listed in the chart (fig. 31) you may need to make a few gear changes.

### DISCONNECT POWER TO MACHINE

- 1) Take off the gear cover (located on the left side of the lathe) by removing the two knobs.
- 2) Remove a socket head screw, a flat washer, and a spacer to replace either gear "a or c" with another gear (fig. 46). Note: DO NOT place anything hard between the gears to prevent rotation or you could break the teeth.
- 3) Loosen the pivot nut to rotate the bracket of gear "b". By loosening the nut on the backside of gear "b" you will be able to slide the gear in the bracket slot.
- 4) After the gears are changed out, make sure they mesh properly before re-tightening.



figure 45

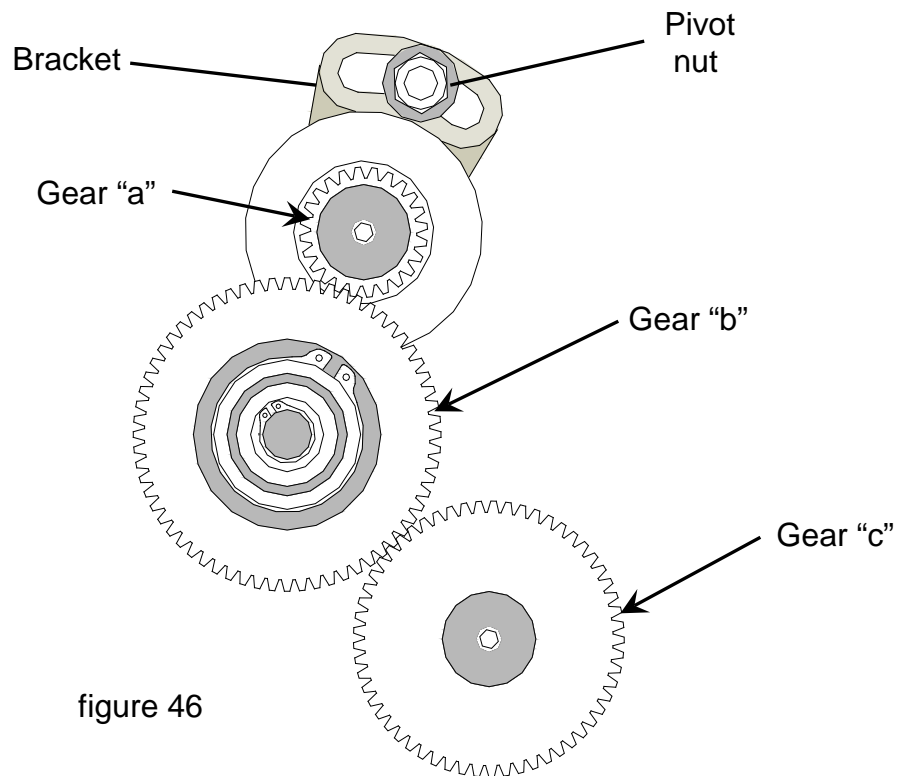

figure 46

## **TEST RUN**

- 1) Before proceeding with a test run, check that the machine is securely mounted in place and that you have read and understand the Operator Safety Instructions at the beginning of this manual.
- 2) Make sure the machine is properly grounded and the fwd/rev handle is in neutral.
- 3) Inspect the lathe bed and rest of the machine for any tools and loose parts. Check that all guarding is in place, and that nothing is obstructing the movement of the chuck.
- 4) Check that the gearbox and carriage sight glasses show adequate oil levels.
- 5) Check the tension of the two V-belts located under the gear cover. You should be able to depress the belts about 1/2" (12.7mm) with normal finger pressure. If they are too tight you could damage the shaft bearing.
- 6) Select the slowest spindle speed (30 RPM) and let the machine run at that speed for 20 minutes. If everything seems to be functioning normally, increase the spindle speed a step at a time until you reach the maximum speed of 2000 RPM. (Fig. 28) shows the handles and dial indicating the various speeds. Run each speed change for approximately 5 minutes. Make sure motor has completely stopped before changing speeds.



**WARNING: BEFORE PERFORMING THE FOLLOWING ADJUSTMENTS, LOCKOUT POWER TO THE MACHINE.**

## MACHINE ADJUSTMENTS

### Spindle

The massive alloy steel spindle is supported on three high precision bearings. Two closely coupled tapered roller bearings offer maximum axial and radial load capabilities and a precision deep groove ball bearing supports the outboard end.

### Spindle Bearing Adjustment

If after prolonged usage it becomes necessary to tighten the spindle bearings, follow the procedure below:

- 1) Remove the headstock cover.
- 2) Position the High / Low gear shift lever (**15**) to NEUTRAL. (Spindle will be free to rotate)
- 3) Loosen the “gear positioning nut” (#2) (fig. 47) at least one full turn. Requires first loosening the lock screw on castellated nut so nut can turn.

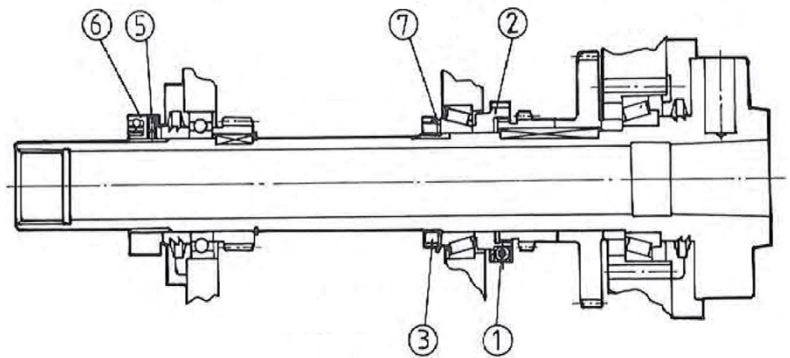

figure 47

- 4) Tighten “Bearing Adjustment” (#3) using spanner wrench. **DO NOT OVER-TIGHTEN**. Spindle should be snug, but free to rotate by hand. End play (float) should not exceed .0002” / .0003” (.0051 / .0076mm) maximum.
- 5) Re-tighten gear positioning nut (#2) (fig. 47) to prevent side float of spindle gears. When this nut is fully tightened, find the locking screw (#1) on the castellated nut and tighten to prevent it from working loose.
- 6) Replace the headstock cover and again check spindle rotation by hand.
- 7) Place High / Low gear shift lever (**15**) in **LOW** position. Check spindle rotation by using the spindle jog button (**1**) (fig 27). If all seems ok, select a low to medium speed, turn the lathe ON, and allow the spindle to run in a “No Load” condition for 20 -30 minutes. With power OFF, check the spindle nose bearing temperature with your hand. If there is a significant heat build-up, recheck the bearing adjustment and correct if necessary. **DO NOT** allow the bearing to overheat.



### Tapered Gib Adjustment

Both the cross slide and the compound rest are equipped with tapered-fully adjustable gibs.

- 1) Position the slide (lengthwise) on the dovetail way so that there is no “overhang” of the way.
- 2) Back off the gib locking screw at the rear end of the slide.
- 3) Adjust the front gib screw until the slide is snug. Re-tighten the gib locking screw at the rear of the slide. **DO NOT OVER-TIGHTEN.**
- 4) Recheck the fit or feel of the slide and re-adjust if necessary.

### Lathe Alignment

- 1) Position the test bar between the dead centers (one in the main spindle taper and one in the tailstock taper).
- 2) Determine the direction and amount of misalignment with a dial indicator mounted on the saddle. The indicator pointer should be against the side of the test bar as it traverses from end to end on the test bar.

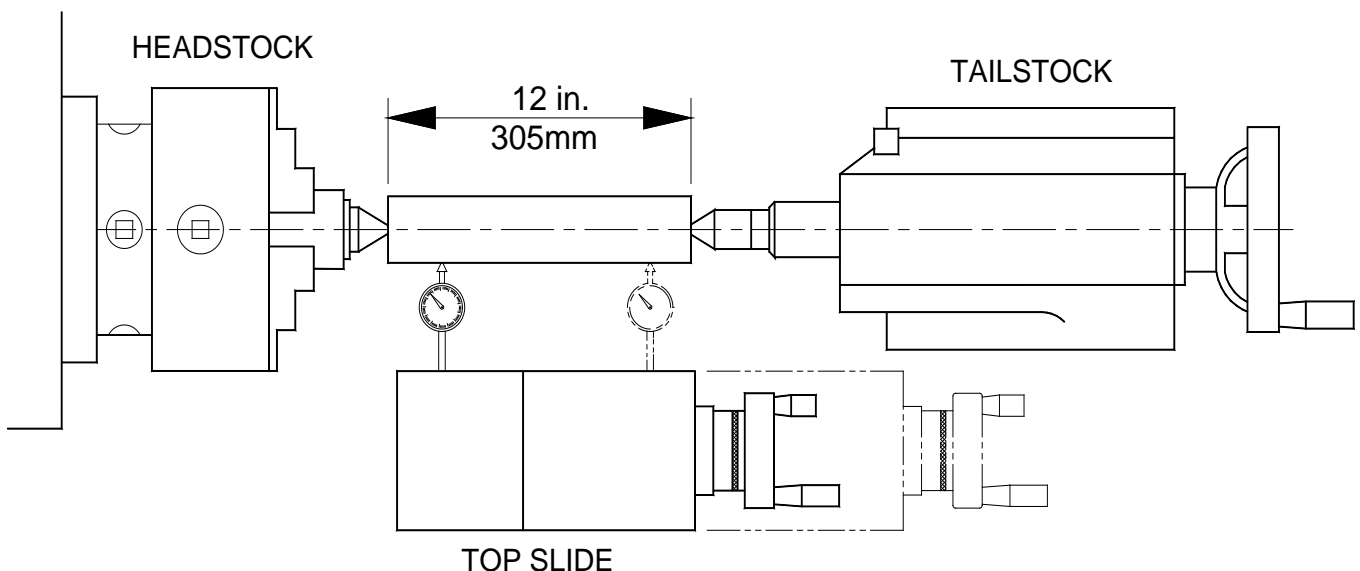

figure 48



To correct any side to side error release the tailstock clamp lever (A). Using the two adjustment screws on either side of the tailstock base and the scale, lineup the the tailstock to the headstock. Tighten the clamp lever and re-check the alignment until perfect.

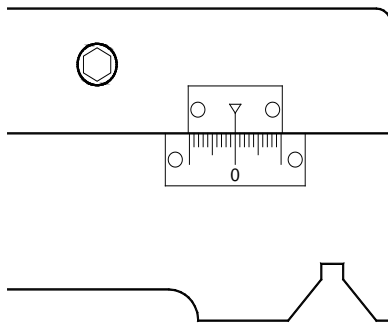

figure 49

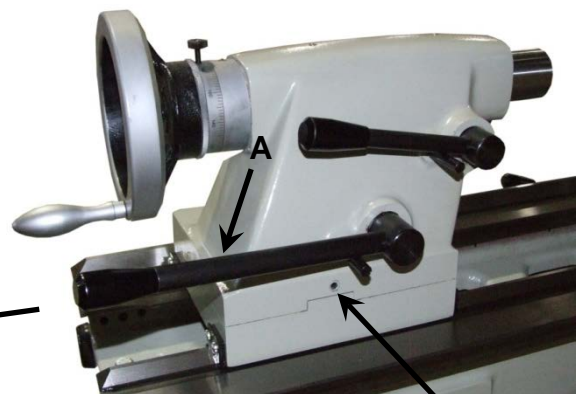

figure 50

Adjustment  
Screw

### Half Nut Adjustment

To maintain the original smooth and accurate operation of the half nut, an adjustable gib strip is provided.

- 1) Remove the thread dial indicator (27) (one bolt-see arrow).
- 2) Loosen the four lock nuts of the gib adjusting screws.
- 3) Adjust the four gib adjusting screws evenly; center two screws first, until a smooth motion is felt while working the half nut engagement lever.
- 4) When lever motion is smooth, re-tighten lock nuts.
- 5) Observe actual half nut engagement with the lead screw to see that no misalignment is occurring.
- 6) Replace the thread dial indicator (27).

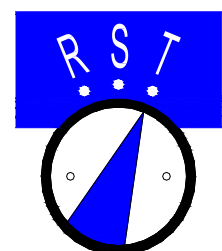

figure 51

### Lead Screw Adjustment

Adjustment is made at the tailstock end mounting bracket, but only if end float or side play exists.

- 1) Disengage lead screw by placing feed selection knob (7) in the "T" position as shown at right.





- 2) Remove the end dust cover from the mounting bracket.
- 3) Loosen the setscrew in the round locking nut.
- 4) Adjust the locking nut (while rotating the lead screw by hand to avoid over-tightening or binding). The lead screw should rotate freely and have no more than 0.0004" (0.01mm) of end play.
- 5) Re-tighten set screw on round locking nut.
- 6) Replace the lead screw dust cover.

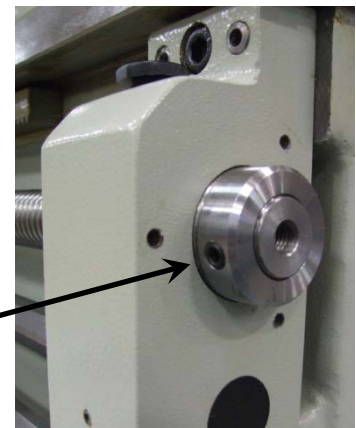

figure 52

### V-Belt Removal and Adjustment



**WARNING:** Always disconnect and lockout electric power to the lathe before servicing.

**NOTE:** Always replace belts as a matched set of three.

V-belts will stretch through usage. Check the tension of the belts every three months. More often if the lathe is used daily.

- 1) To access the drive belts, remove the top gear cover, the lower end plate, and the lower back plate from the head stock end of the lathe (fig. 53 & fig. 54).
- 2) Remove the hex nut and washers as indicated by the arrow in (fig. 53).
- 3) Carefully raise the motor bracket up to release tension on the belts so they can be removed. (Note that the brake assembly also raises with the motor)
- 4) Place the new belts onto the three groove pulley and let the motor down gently.



- 5) Replace the washers and the hex nut and tighten the motor bracket down securely. After tightening, push the center of each belt. When properly tensioned the amount of deflection should be approximately 0.75" (19mm).



**Note:** If you change the position of the motor mounting bracket due to belt stretching or belt replacement, it may be necessary to re-adjust the foot pedal brake and the micro limit switch.



figure 53



figure 54

#### Foot Brake Adjustment

The pedal can be adjusted for height and the brake band will eventually show wear and need to be adjusted.

- 1) To change the pedal height, loosen the jam nut (A) on the adjusting bolt. Make the adjustment with the bolt and re-tighten the jam nut.
- 2) To adjust the brake band, loosen the jam nut (B) on the adjusting bolt. Make the bolt adjustment and re-tighten the jam nut. With the foot pedal, test the new adjustment.

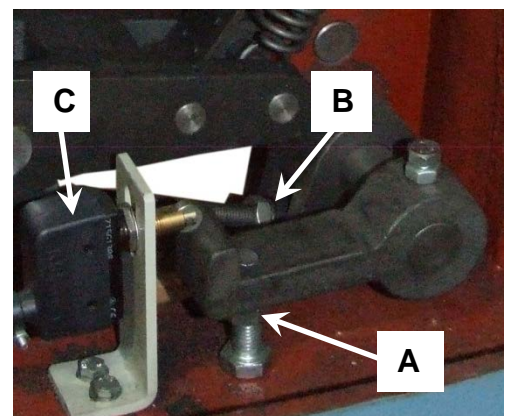

figure 55



- To adjust the micro switch (C) (fig. 55), loosen the jam nut. Raise or lower the switch in the slot for best contact with the brake actuator bar. Re-tighten jam nut.

### Saddle Adjustment

Prolonged / extensive use may require that the carriage (saddle) gibs be re-adjusted in order to restore original rigidity and accuracy.

#### **Front:**

Wear on the front saddle strip may be remedied by rescraping the contact surface of the strip. First remove the socket head capscrew (#1) and take off the front strip for rescraping. Re-install the strip after scraping. **Note: DO NOT over scrape.**

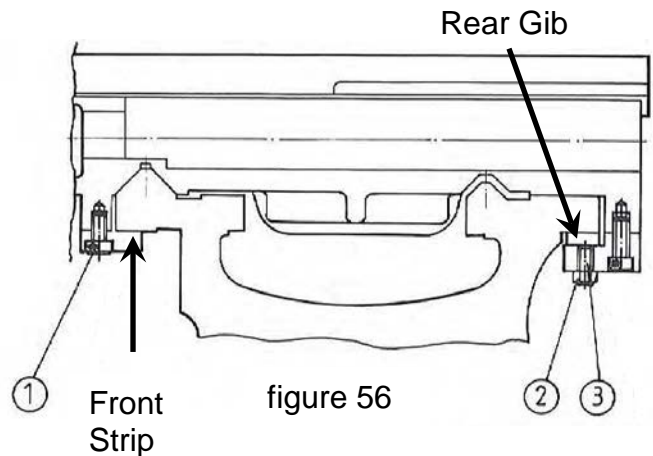

figure 56

#### **Rear:**

Adjustments are made at the flat gib strip under the rear slide of the saddle.

- Loosen the four lock nuts (#2) of gib adjusting screws (#3) (one full turn)
- Adjust the four gib adjusting screws evenly, center two screws first, until the correct adjustment is achieved while working the apron hand wheel.
- Re-tighten the lock nuts and repeat steps 1 – 3 (if needed).

### Cross feed Screw / Nut Backlash Adjustment

If the cross feed screw and nut assembly become worn to the extent that accuracy is diminished appreciably, they should both be replaced. If some wear has occurred, you can reduce the effect of the wear by adjusting the two piece nut with the tapered wedge.

- Check that the two (#1) locking screws are tight. Without disturbing locking screws (#1) loosen the two locking screws (#3).
- Tighten socket head screw (#2) onto the tapered wedge. (a very slight adjustment)

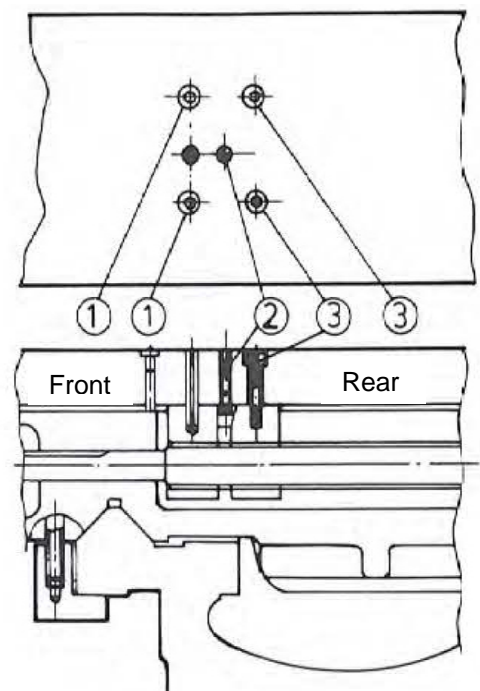

figure 57



- 3) Check the amount of back-lash on the cross feed dial. A dial indicator can be used to determine actual slide movement.
- 4) Repeat tightening of setscrew (#2) if required until the back lash is eliminated.
- 5) Re-tighten the two (#3) locking screws.

**CAUTION: NORMAL WEAR TENDS TO OCCUR NEAR THE CENTER TRAVEL POSITION ON THE SCREW. THEREFORE, TO AVOID BINDING YOU SHOULD MAKE THE ADJUSTMENTS WITH THE NUT IN ONE EXTREME OR THE OTHER WHERE THE WEAR IS AT A MINIMUM.**

### **Feed Rod Adjustment**

The feed rod and feed gears are protected from overload by an adjustable tension cone clutch located in the apron.

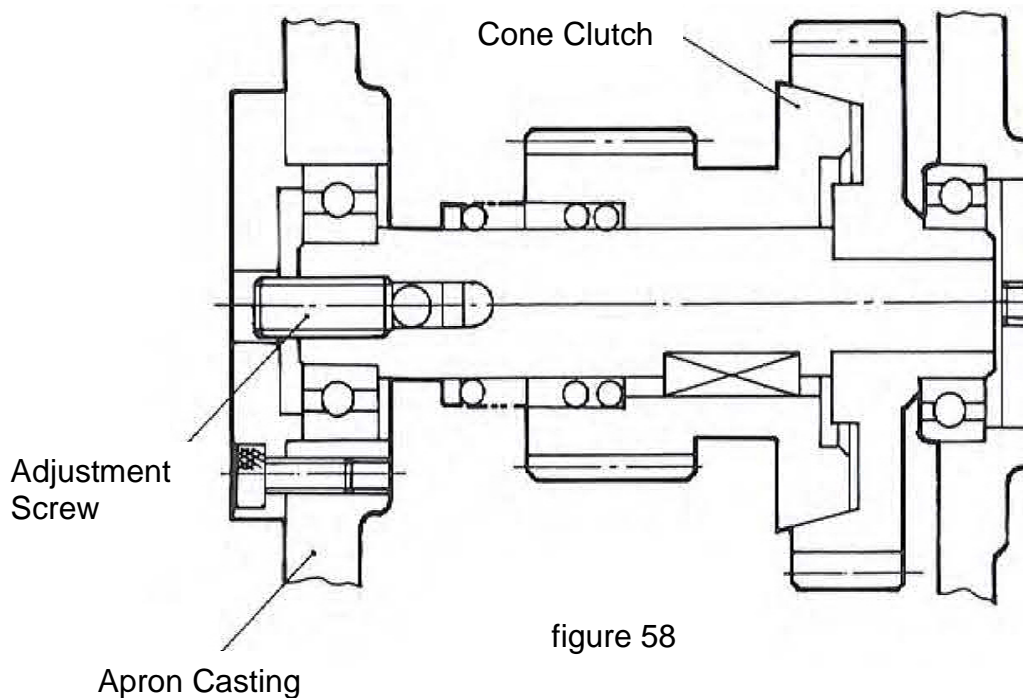

figure 58

Turn adjusting knob clockwise (**cw**) to increase driving power.

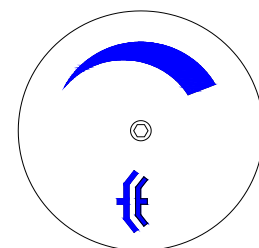

figure 59



## LUBRICATION AND MAINTENANCE



### **WARNING:**

**Always disconnect and lockout electric power to the lathe before servicing. NEVER lubricate the lathe while it is running.**

*MAINTENANCE SHOULD BE PERFORMED ON A REGULAR BASIS BY QUALIFIED PERSONNEL*

### **Headstock**

To fill the head stock, first take off the end gear cover. Remove the plug from the street elbow as indicated with the arrow in (fig. 60). Fill with Shell Tellus #32 oil, approx. 1 1/2 gallon (6 liters) or until the level in the sight glass is at the halfway mark. The first oil change should be after approx. 200 hours. Thereafter about every 6 months.

To drain the oil, connect a hose or tube to the valve shown at right. Turn the handle 90° clockwise (**cw**) to open the valve.



Drain Valve



figure 60



### Quick Change Gear Box

To fill the Gear Box, first take off the end gear cover. Remove the oil fill cap as shown in (fig. 61). Fill with Shell Tellus #68 oil, approx. 1 1/4 gallon (5 liters) or until the level in the sight glass is at the halfway mark. Change oil every 6 months.

The reservoir is an oil bath (dip)

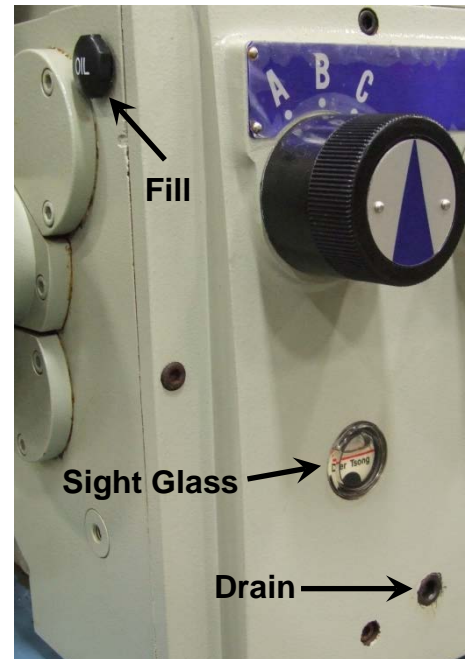

figure 61

### Apron

The apron is lubricated from an internal reservoir of oil. Ensure that the sight gauge shows oil at the halfway mark. To fill the apron, remove the fill cap. Add 1/2 gallon (approx. 2 liters) of Shell Tellus #68 oil. The drain plug is located at the bottom of the apron (fig. 62).

### Sight Glass

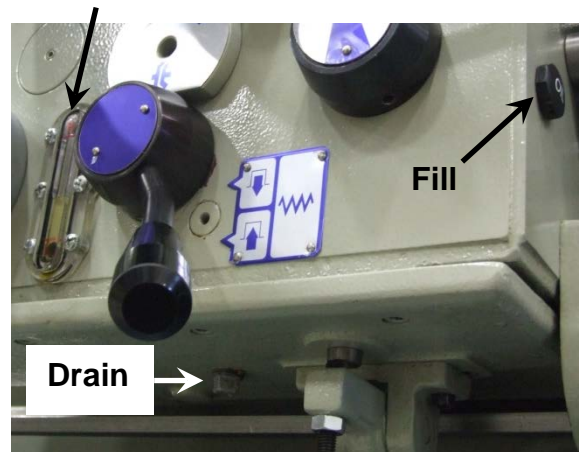

figure 62

### Lead screw, Feed Rod, and Half Nut

Lubricate surfaces daily with brush or cloth. Lead screw must be cleaned and threads lightly oiled. Remove cap on lead screw bracket to fill with Shell Tellus #32 oil. To replace oil, remove the drain plug as shown in (fig. 63).

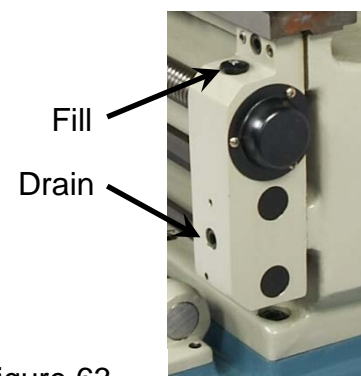

figure 63



### **Bed Ways, Saddle, and Cross Slide**

Before operation, push the one-shot pump (1 – 3) times, three times a day under normal usage. The oil comes from the apron reservoir. The oil flow is controlled with the lube flow adjustor.

Lube Flow  
Adjustor



figure 64

### **Tail Stock**

Oil the tailstock daily at the three oil fittings located at the top of the tailstock (see fig. 65). Lubricate with 2 – 3 drops of a light lubricating oil.

Oiler Points

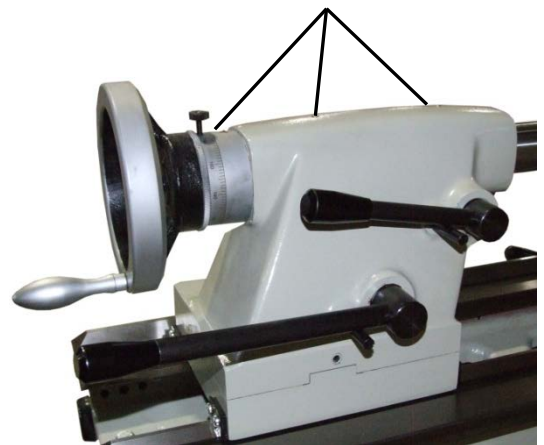

figure 65

### **Quick Change Gears**

Inspect and grease the gear teeth weekly. The gears must not be allowed to run dry. Re-attach gear cover after lubricating.



figure 66



### Compound Rest, Cross Slide, Feed Screw, & Nut

Lubricate indicated fittings (fig. 67) with 2 – 3 drops daily, or as needed, with a Shell Tellus 32 oil or equivalent.

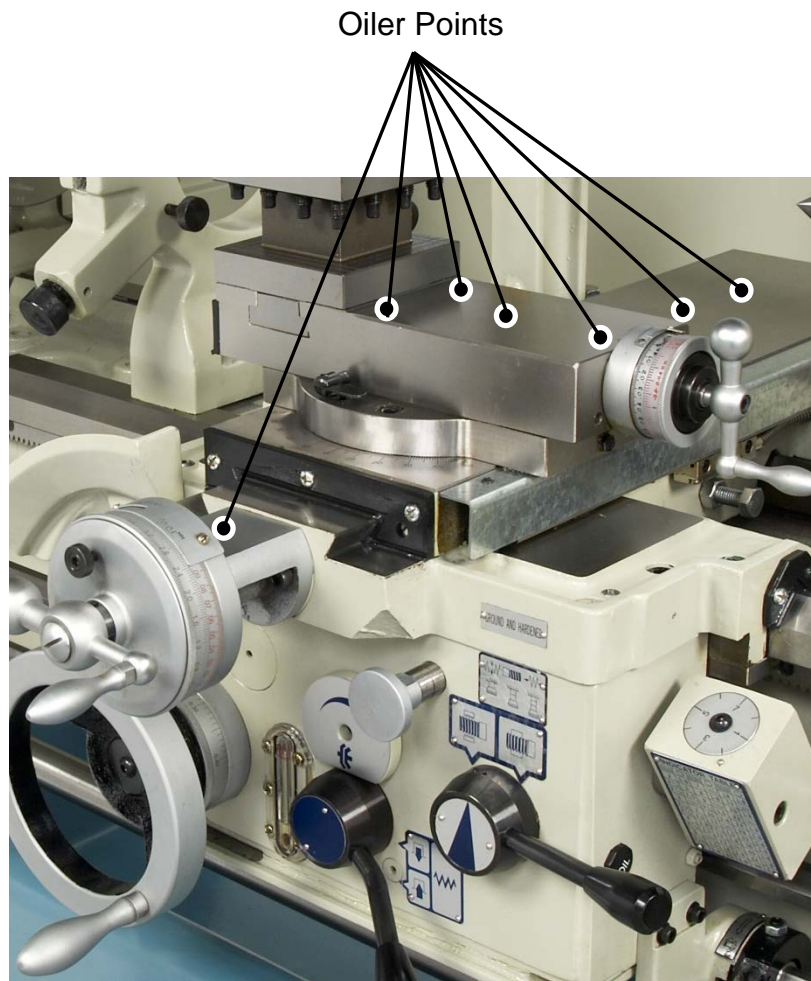

figure 67



### Daily Maintenance

- Do a general cleaning by removing dust and metal chips from the machine.
- Top off the coolant tank. (80% of full tank capacity)
- Clean drain screen.
- Check that any guarding, shields, and emergency stop are in good working order.
- Inspect brake pedal and brake switch for proper operation.
- Wipe down and re-oil slideways.

### Weekly Maintenance

- Thoroughly clean the machine including the coolant tank.
- Check sight glasses for gear oil levels (add oil as needed)

### 3 Month Maintenance

- After initial 3 months replace the headstock, gearbox, and apron oil and then every six months after that.

### Oil Disposal

Used oil products must be disposed of in a proper manner following your local regulations.

### Accessing and Cleaning the Coolant System

- The coolant tank is located at the back of the lathe and is an integral part of the frame. See (fig. 69)
- Remove the top access cover screen for access to the reservoir.
- To access the motor and pump remove the rear panel as in (fig. 68)
- Suction the coolant from the tank, and wash out any dirt and debris. (Check for anything that might be obstructing the pump inlet.)
- Refill the tank with coolant solution. (80% of full tank capacity)
- Replace both access covers.

### Oils for Lubricating Coolant

Any 10:1 (water to coolant) solution will work, however we recommend **Baileigh B-Cool** 20:1 (water to coolant) biodegradable metal cutting fluid. It has excellent cooling and heat transfer characteristics, is non-flammable, and extends tool and machine life. Each gallon of concentrate makes 21 gallons of coolant .



figure 68

(Shown with covers removed)



figure 69

### **Storing Machine for Extended Period of Time**

If the Lathe is to be inactive for a long period of time, prepare the machine as follows:

- Detach the plug from the electrical supply panel.
- Remove the chuck, steady rest, follow rest, tool post, and tail stock. Cover with a rust protectant.
- Empty and clean the coolant tank.
- Clean and grease the machine so no bare metal is left unprotected.
- Use desiccant bags (if available) to absorb moisture.
- Cover the machine

Your machine is designed and manufactured to work smoothly and efficiently. Following proper maintenance instructions will help ensure this. Try and use original spare parts, whenever possible, and most importantly; **DO NOT** overload the machine or make any unauthorized modifications.

### **TECHNICAL SUPPORT**

Our technical support department can be reached at **920.684.4990**, and asking for the support desk for purchased machines. Tech Support handles questions on machine setup, schematics, warranty issues, and individual parts needs.

For specific application needs or future machine purchases contact the Sales Department. at: [sales@baileighindustrial.com](mailto:sales@baileighindustrial.com) or phone: **920.684.4990**



Notes

**BAILEIGH INDUSTRIAL, INC. 1625 DUFEK DRIVE MANITOWOC, WI 54220**

**PHONE: 920. 684. 4990 FAX: 920. 684. 3944**

**WWW.BAILEIGHINDUSTRIAL.COM**

**BAILEIGH INDUSTRIAL, INC. 1455 S. CAMPUS AVENUE ONTARIO, CA 91761**

**PHONE: 920. 684. 4990 FAX: 920. 684. 3944**

**BAILEIGH INDUSTRIAL LTD. UNIT 1 FULLWOOD CLOSE**

**ALDERMANS GREEN INDUSTRIAL ESTATE**

**COVENTRY, CV2 2SS UNITED KINGDOM**

**PHONE: +44 (0)24 7661 9267 FAX: +44 (0)24 7661 9276**

**WWW.BAILEIGHINDUSTRIAL.CO.UK**

**BAILEIGH INDUSTRIAL GMBH HOFENER STRAÙE 64**

**70736 FELLBACH**

**DEUTSCHLAND**

**WWW.BAILEIGHINDUSTRIAL.DE**