



ELECTRICAL / PARTS MANUAL



METAL LATHE MODEL: PL-1860

Baileigh Industrial, Inc.
P.O. Box 531
Manitowoc, WI 54221-0531
Phone: 920.684.4990
Fax: 920.684.3944
sales@baileighindustrial.com

Book 2 of 3

REPRODUCTION OF THIS MANUAL IN ANY FORM WITHOUT WRITTEN APPROVAL OF BAILEIGH INDUSTRIAL, INC. IS PROHIBITED. Baileigh Industrial, Inc. does not assume and hereby disclaims any liability for any damage or loss caused by an omission or error in this Operator's Manual, resulting from accident, negligence, or other occurrence.



Table of Contents

ELECTRICAL SCHEMATIC COMPONENTS	1
ELECTRICAL SCHEMATIC	2
ELECTRICAL PANEL	3
TROUBLESHOOTING	4
HEADSTOCK ASSEMBLY 1/5.....	8
HEADSTOCK ASSEMBLY 2/5.....	9
HEADSTOCK ASSEMBLY 3/5.....	10
HEADSTOCK ASSEMBLY 4/5.....	11
HEADSTOCK ASSEMBLY 5/5.....	12
HEADSTOCK PARTS IDENTIFICATION	13
GEARBOX ASSEMBLY 1/4	19
GEARBOX ASSEMBLY 2/4	20
GEARBOX ASSEMBLY 3/4	21
GEARBOX ASSEMBLY 4/4	22
GEARBOX PARTS IDENTIFICATION	23
CARRIAGE ASSEMBLY 1/7	27
CARRIAGE ASSEMBLY 2/7	28
CARRIAGE ASSEMBLY 3/7	29
CARRIAGE ASSEMBLY 4/7	30
CARRIAGE ASSEMBLY 5/7	31
CARRIAGE ASSEMBLY 6/7	32
CARRIAGE ASSEMBLY 7/7	33
CARRIAGE PARTS IDENTIFICATION	34
APRON ASSEMBLY (Left Hand) 1/5	39
APRON ASSEMBLY (LEFT HAND) 2/5.....	40
APRON ASSEMBLY (LEFT HAND) 3/5.....	41
APRON ASSEMBLY (LEFT HAND) 4/5.....	42
APRON ASSEMBLY (LEFT HAND) 5/5.....	43
APRON PARTS IDENTIFICATION	44
TAIL STOCK ASSEMBLY 1/2	50
TAIL STOCK ASSEMBLY 2/2	51
TAIL STOCK PARTS IDENTIFICATION	52
BED ASSEMBLY 1/2	54
BED ASSEMBLY 2/2	55
BED PARTS IDENTIFICATION	56



ELECTRICAL SCHEMATIC COMPONENTS

Part No.	Type	Specification	Name
LSTM1308	LS-1	15A 125VAC TM 1308 (Z-15GQ22-B)	Guard Limit Sw. (N.O.)
LSTM1308	LS-5	15A 125VAC TM 1308 (Z-15GQ22-B)	Chuck Limit Sw. (Close)
LSTM1308	LS-2	15A 125VAC TM 1308 (Z-15GQ22-B)	Brake Limit Sw. (Close)
LSTM1704	LS-3	15A 125VAC TM 1704 (Z15 GW-22-B)	Fwd. Micro Sw. (Open)
LSTM1704	LS-4	15A 125VAC TM 1704 (Z15 GW-22-B)	Rev. Micro Sw. (Open)
PS2,03,11+OP	CS-1	BR2,03< 11+OP 32A	Main Switch (Power)
CS0130G1A	CS-2	6A 250VAC 1A Ø30 G	Coolant Pump Switch
FS0250A FS0230A	F1	50A For 220/30A for 380V & Above	Listed Fuse
FS0105A	F2	5A	Circuit Fuse
WLHP252	PL-1	AC 12V	Working Light
PL0130W110V	PL-2	110V 15V Ø30 W (Lamp 18V 2W	Pilot Lamp.
PB0130R1A1B	PB-2	10A 250VAC, 1d1b (Connected 1b)Ø30,R	Emergency Stop (P.B.)
PB0430G1A	PB-1	6A 250VAC,1dØ30,G	Inching
MS01C-25G	MS-1	C-25G 50A, 110V,5d2b	Magnetic Contactor-Fwd.
MS01C-25G	MS-2	C-25G 50A, 110V,5d2b	Magnetic Contactor-Rev.
MS01C-11G	MS-3	C-11G 20A 110V 4d	Mag. Contactor-Coolant
MS01C-11G	CR-1	C-11G 20A 110V 4d	Control Relay
OL01RH-18/26/ OL01RH-18/15/	OL-1	RH-18/26 110V,21-34A For 220V RH- 18/15 A For 380V & Above	Thermal Relay (Spindle F/R
OL02RH-10E/0.55	OL-2	RH-10E/0.55 110V.043~0.67A	Thermal Relay (Coolant)
TRVA1503220/12	T-1	VA150 380 (220/440) /12V	Ctrl. Circuit Transformer

ATTENTION: HAVE ELECTRICAL UTILITIES CONNECTED TO MACHINE BY A CERTIFIED ELECTRICIAN!

Your Baileigh Machine is  Certified

Check if the available power supply is the same as required by the machine (consult nameplate on machine)



ELECTRICAL SCHEMATIC

7 1/2 Horsepower, External Mounting Box, Chuck Limit Switch

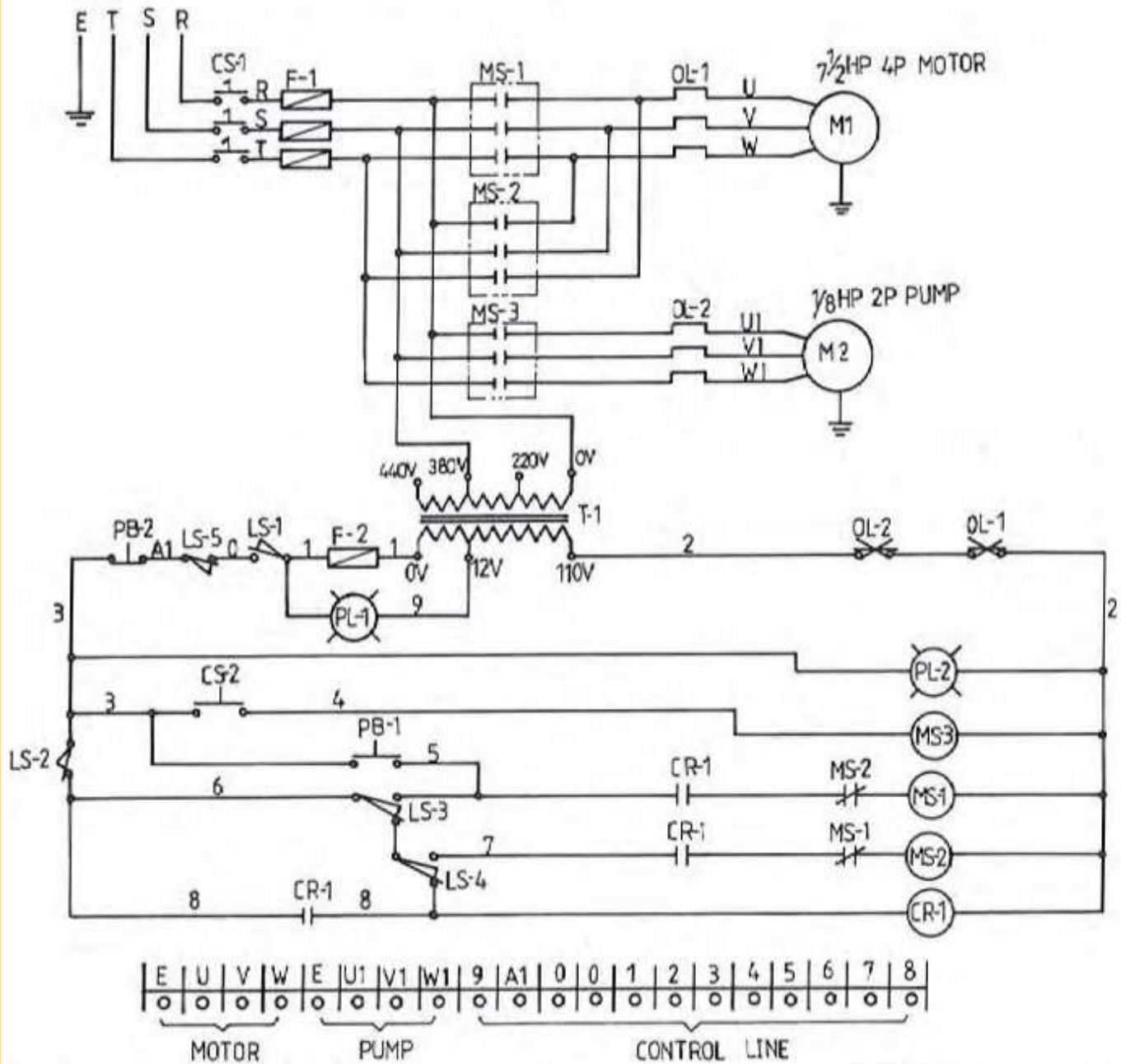



ELECTRICAL PANEL

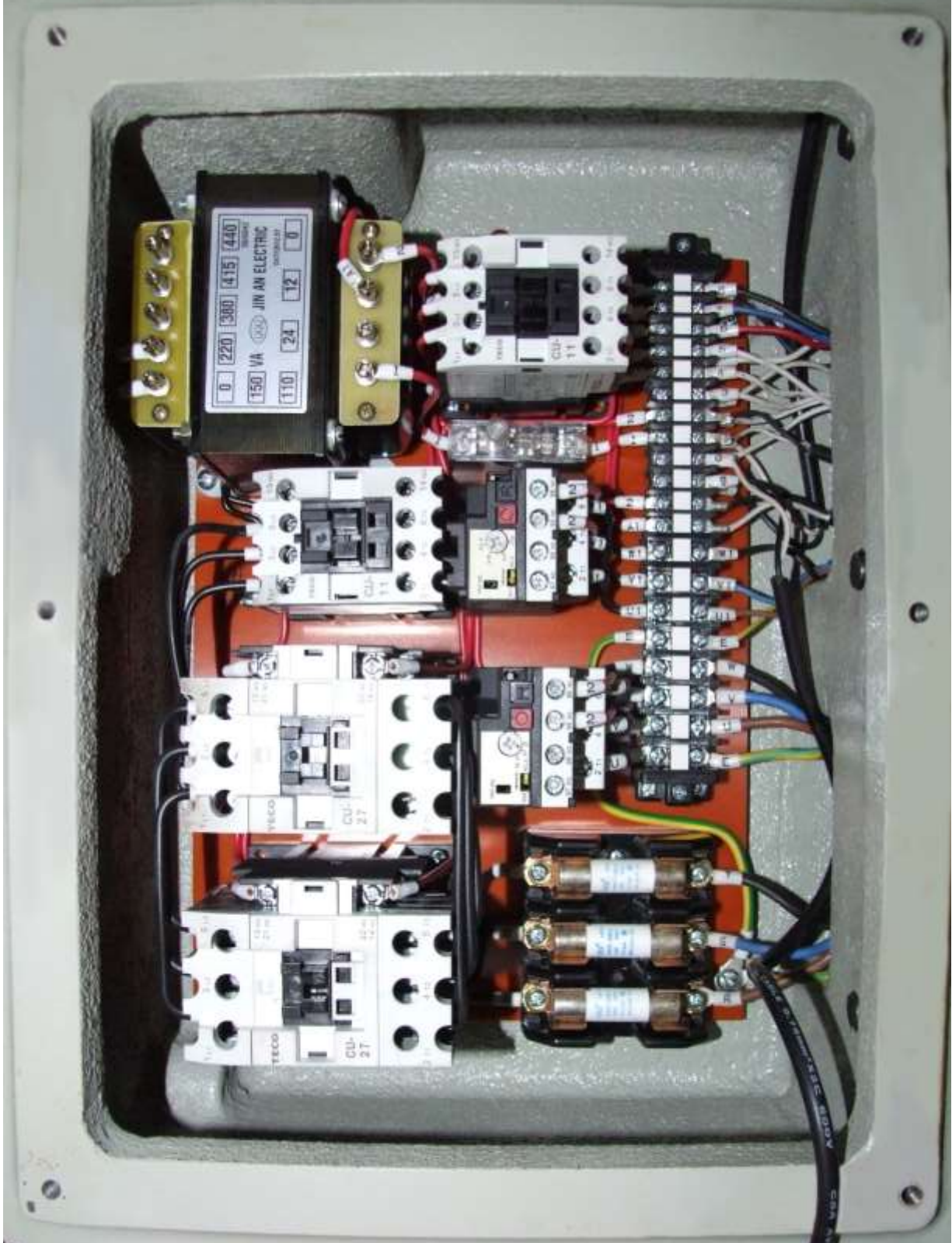



TROUBLESHOOTING

⚠ WARNING: Make sure the electrical disconnect is OFF before working on the machine.

SYMPTOM	POSSIBLE CAUSE(S)	CORRECTIVE ACTION
Motor Does Not Start	No power.	Check the power source.
	Emergency stop button not reset.	Release the emergency button by turning the knob to the right.
	Motor damaged.	Replace motor.
	Motor power cable not connected properly.	Check the cable connection and reconnect cable. Change cable if worn out.
	Motor circuit breaker tripped.	Reset the breaker to ON position.
	Magnetic switch damaged or burned out.	Replace switch.
	Transformer damaged.	Replace transformer.
	Forward/Reverse lever on the carriage is in neutral.	Make sure lever is either in Forward or Reverse position.
Circuit Breaker Trips	Foot brake limit switch is faulty.	Replace limit switch.
	Chuck Guard Raised or faulty micro switch.	Lower guard or replace switch.
	Gear cover removed or faulty gear cover micro switch.	Replace gear cover or replace faulty switch.
	Short circuit in power cord or plug.	Inspect cord or plug for damaged insulation or shorted wires.
Circuit Breaker Trips	Loose connections or short circuit in motor.	Inspect all motor connections.
	Incorrect circuit breaker installed.	Install correct circuit breaker.



SYMPTOM	POSSIBLE CAUSE(S)	CORRECTIVE ACTION
Gear Change Levers Will Not Shift	Gears not aligned in headstock.	Maintain pressure on the lever while rotating the spindle with the jog button until the gear falls into place.
Poor Surface Finish	Incorrect spindle speed or feed rate. Dull tool or improper tool selection. Depth of cut too much. Too much play in gibs.	Adjust for proper feed rate and spindle speed. Use sharp tools and select proper tool for the application. Use more passes to remove less material. Follow gib adjustment procedure.
Machine Vibrates Excessively at Startup and While Running	Piece part is not properly balanced. Check for broken or worn gear. Unbalanced chuck or faceplate.	Re-position piece part so it is centered with the spindle bore. Inspect gears and replace when necessary. Have chuck or faceplate either re-balanced or replaced.
Excessive Vibration of Tool or Machine While Cutting	Tool holder is loose. Tool not properly supported in tool holder. Removing too much material from piece part in one pass. Gibs are not properly adjusted. Cutting tool dull or broken.	Clean slide and re-tighten tool holder. No more than 1/3 of tool should extend from holder. Secure tool properly. Take more passes and reduce depth of cut. Check gibs and re-adjust if needed. Re-sharpen or replace cutting tool.
Cannot Remove Tool From Tailstock Barrel	Barrel is not retracted completely into tailstock. Taper not properly cleaned before inserting tool.	Turn the tailstock hand wheel until it pushes the tool out from the barrel. Always clean barrel taper before inserting tool.



SYMPTOM	POSSIBLE CAUSE(S)	CORRECTIVE ACTION
Tailstock Barrel Will Not Move	Barrel lock lever is tight	Loosen lever
Cross Slide, Compound Rest, or Carriage Feed is Loose	Gibs need adjustment. Hand wheel is loose. Mechanism for lead screw worn out or in need of adjustment.	Follow procedure to re-adjust gibs. Re-tighten fasteners on hand wheel. Tighten fasteners on lead screw mechanism. Adjust cross slide for backlash.
Hand wheels are Hard to Turn	Gibs are dirty. Gibs may be too tight. Cross slide backlash setting too tight.	Remove gibs, clean ways, lubricate, replace and re-adjust gibs. Loosen gibs slightly until wheel turns freely. Loosen slightly until free.
Inconsistent Turning Results on Piece Part	Headstock and tailstock not aligned to each other. Bed ways are not level front-to-back or side-to-side.	Follow procedure to re-align. Re-level machine as necessary.
Jaws of Chuck Will Not Move	Jaws filled with chips and debris.	Remove and clean the jaws, clean and lubricate chuck threads, replace jaws into chuck.
Carriage Will Not Feed or is Hard to Move	Lock lever on carriage is over tightened. Gears broken or not engaged. Gibs may be over tightened.	Loosen lock lever so carriage is free to move. Adjust or replace gears. Loosen gibs slightly.
Tool Has Short Edge Life	Cutting speed too high for application. Cross feed set too high. Insufficient cooling	Reduce cutting speed. Lower cross increase amount of coolant to tool area. Increase coolant flow.



SYMPTOM	POSSIBLE CAUSE(S)	CORRECTIVE ACTION
Excessive Machine Noise and Overheating	Excessive material removal from piece part. Wrong feed rate or spindle speed. V-Belts are slipping.	Decrease depth of cut. Use correct feed rates and spindle feed values. Inspect, tension, and replace belts.



HEADSTOCK ASSEMBLY 1/5

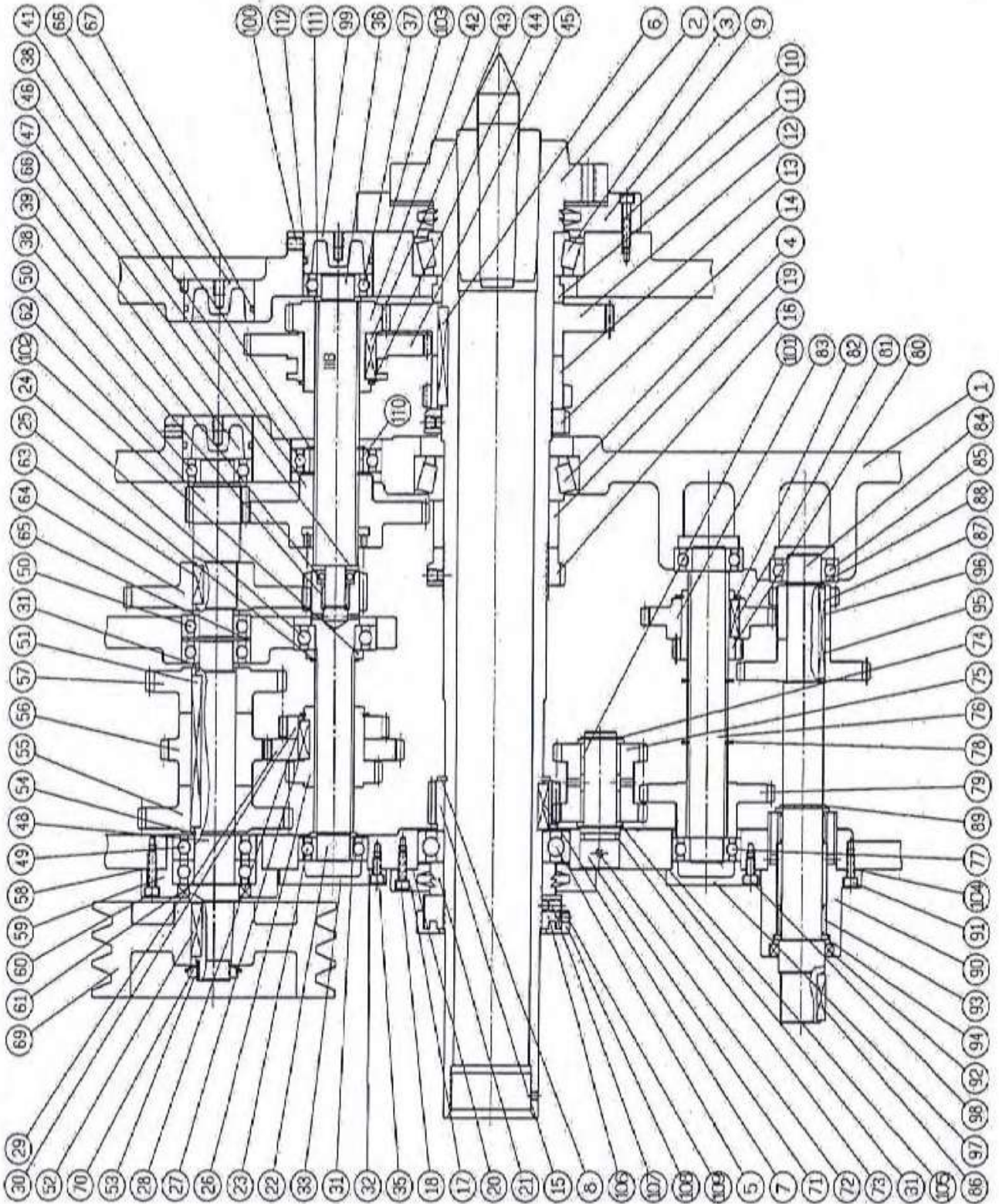



HEADSTOCK ASSEMBLY 2/5

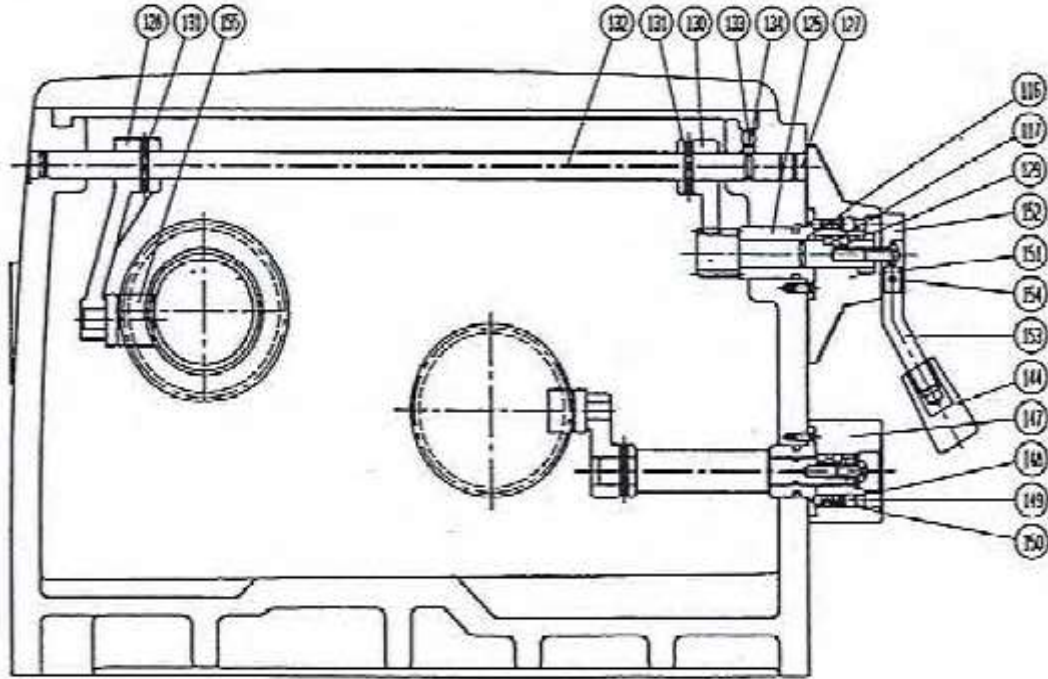

SECTION A-A

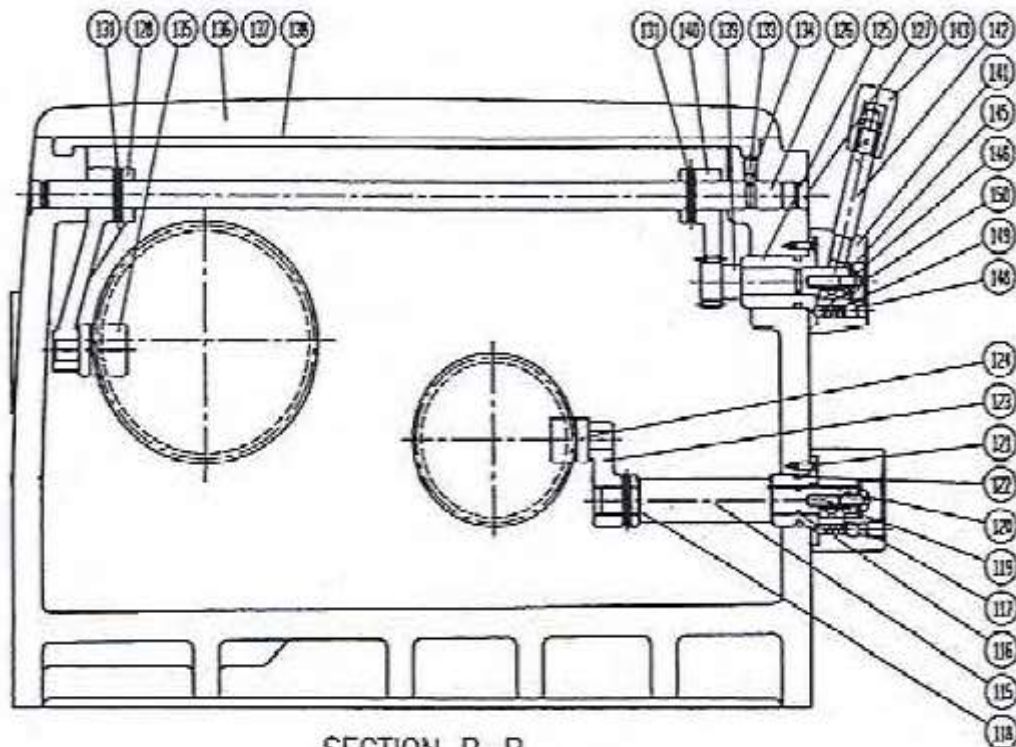

SECTION B-B



HEADSTOCK ASSEMBLY 3/5

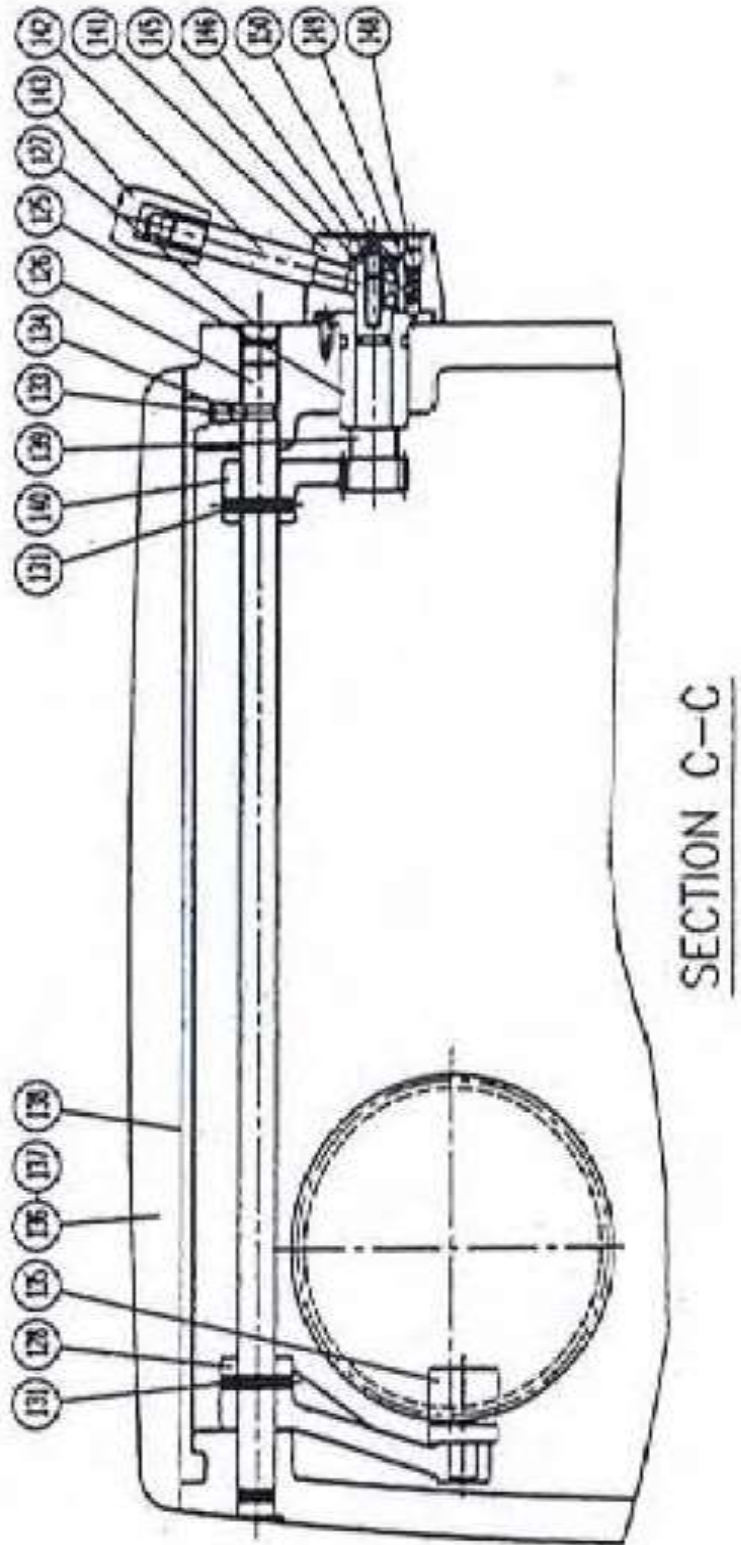



HEADSTOCK ASSEMBLY 4/5

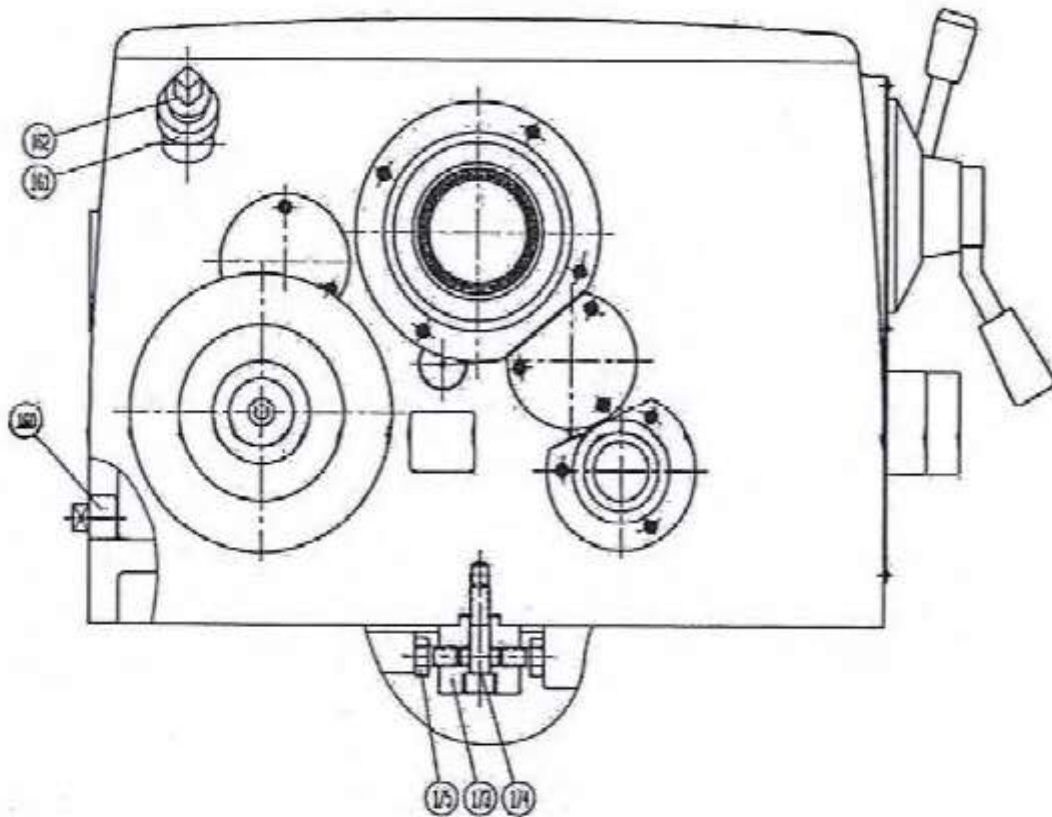
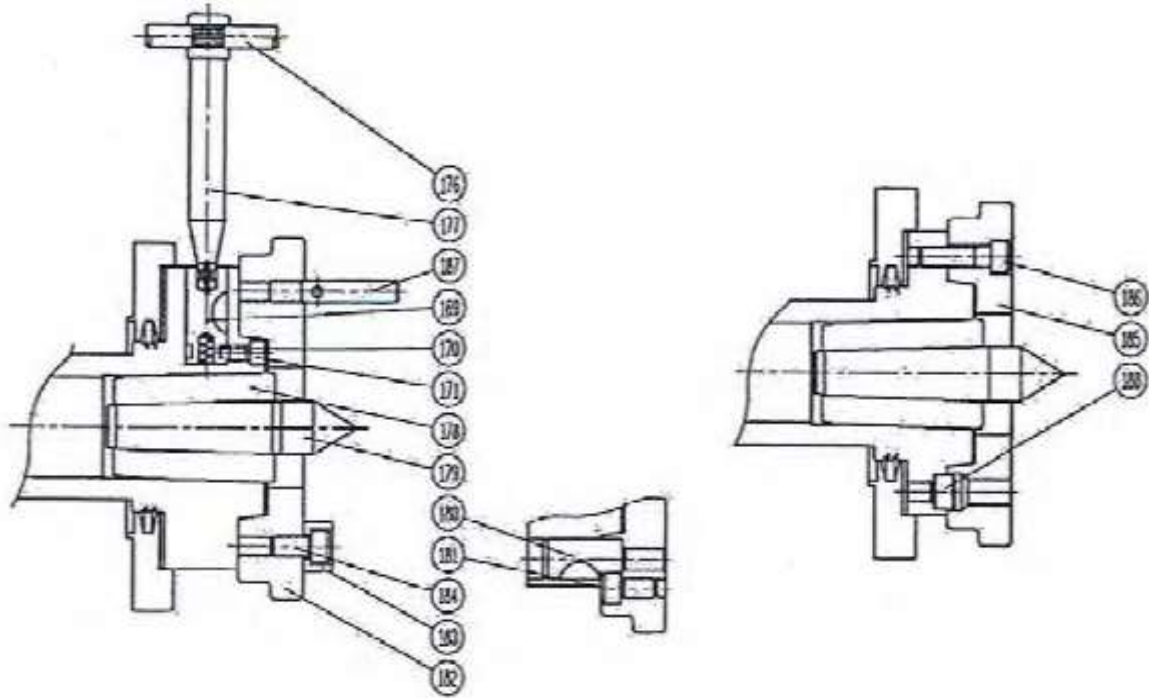



HEADSTOCK ASSEMBLY 5/5

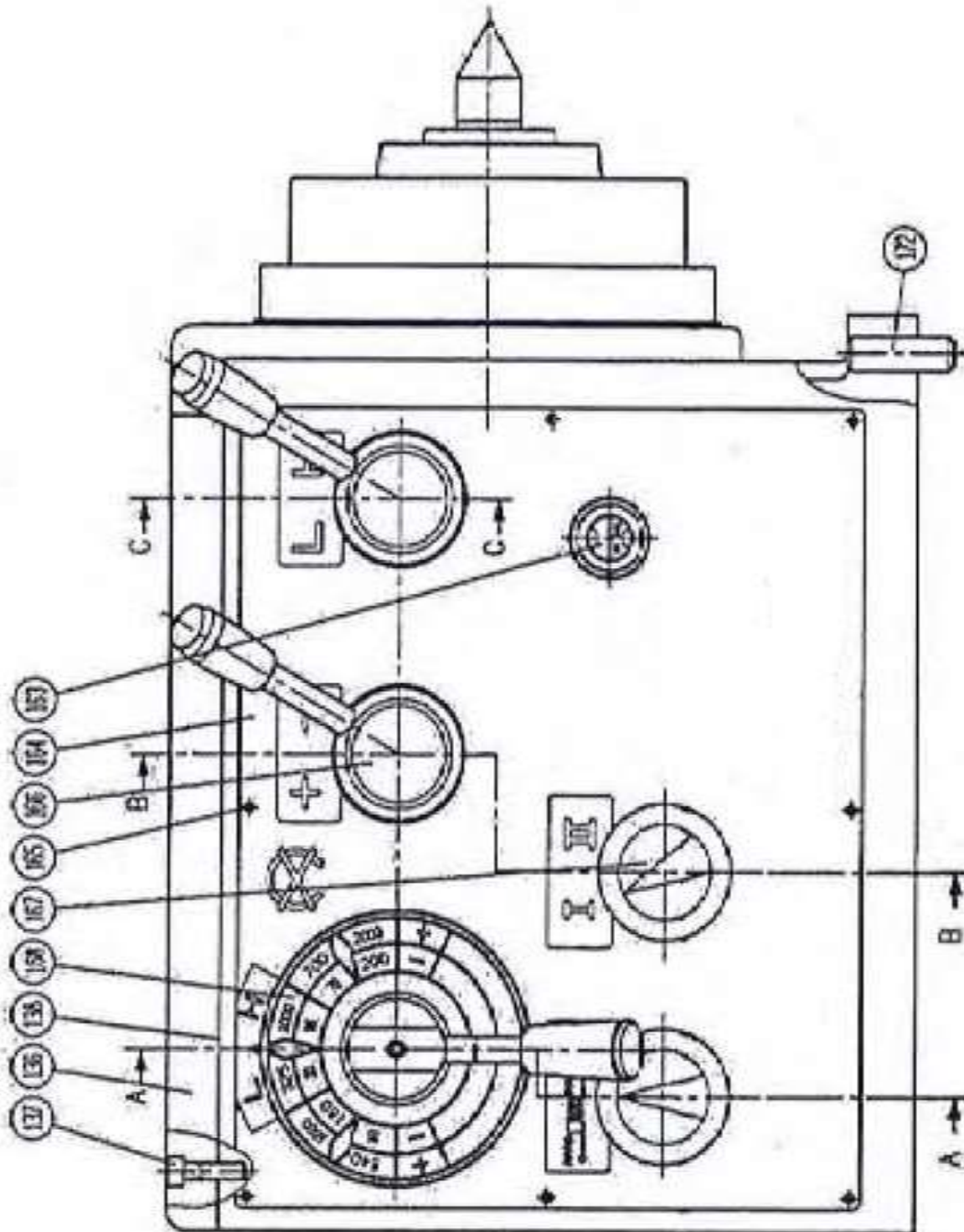



HEADSTOCK PARTS IDENTIFICATION

No.	Part No.	Name	Specification	Qty.
1	62-0101A	Head stock casting		1
2	62-0102C	Spindle	D1-6	1
2	62-0102D	Spindle	A1-6	1
3	RB32017	Taper Roller Bearing	#32017	1
4	RB32016	Taper Roller Bearing	#32016	1
5	RB6015	Deep Groove Ball Bearing	#6015	1
6	KY0310X8X65	Double Round Head Key	10x8x30L	1
7	KY038X8X30	Double Round Head Key	38x8x30L	1
8	RR01STW75	Retaining Ring (External)	STW#75	1
9	50-01103A	Bearing Cover	D1-6	1
9	50-01103B	Bearing Cover	A1-6	1
10	SW02M6X30L	Socket Head Cap Screw	M6xP1.0x30L	6
11	50-0105	Spacer		1
12	50-0106-A0	Gear		1
13	50-0107	Gear		1
14	50-0108	Locking Nut		1
15	62-0106A	Gear		1
16	50-0110	Locking Nut		1
17	62-0111A	Bearing Cover		1
18	SW02M6X20L	Socket Head Cap Screw	M6xP1.0x20L	4
19	50-0109	Spacer		1
20	62-0113	Packing		1
21	50-0115	Spacer		1
22	50-0117	Gear Shaft		1
23	RB6205	Deep Groove Ball Bearing	#6205	1
24	RB6206	Deep Groove Ball Bearing	#6206	1
25	RR01STW30	Retaining Ring (External)	STW#30	1
26	50-0119	Gear		1
27	KY038X8X25	Double Round Head Key	8x8x25L	1
28	RR01STW45	Retaining Ring (External)	STW#45	1
29	50-0120	Gear		1
30	50-0121-A0	Gear		1
31	50-0122	Spacer		5



No.	Part No.	Name	Specification	Qty.
32	50-0123	Packing		1
33	50-0124	Bearing Cover		1
35	SW02M6X12L	Socket Head Cap Screw	M6xP1.0x12L	3
36	50-0125	Shaft		1
37	RB6205	Deep Groove Ball Bearing	#6205	1
38	RB6008	Deep Groove Ball Bearing	#6008	1
39	RBTLA1516	Needle Bearing	#TLA1516	1
40	RB51102	Thrust Ball Bearing	#51102	1
41	RR01STW34	Retaining Ring (External)	STW#34	2
42	50-0126-A0	Gear		1
43	KY038X8X30	Double Round Head Key	8x8x30L	1
44	RR01STW45	Retaining Ring (External)	STW#45	1
45	50-0127	Gear		1
46	50-0128	Gear		1
47	50-0129	Washer		1
48	50-0131	Shaft		1
49	RB6206	Deep Groove Ball Bearing	#6206	2
50	RB6025	Deep Groove Ball Bearing	#6025	3
51	KY038X8X100	Double Round Head Key	8x8x100L	1
52	KY038X8X35	Double Round Head Key	8x8x35L	1
53	SW02M10X25L	Bearing Lock Nut	AN05	1
54	RR01STW30	Retaining Ring (External)	STW#30	1
55	50-0132	Gear		1
56	50-0133	Gear		1
57	50-0134-A0	Gear		1
58	50-0135	Packing		1
59	50-0136	Bearing Cover		1
60	SW02M6X20L	Socket Head Cap Screw	M6xP1.0x20L	3
61	OSTC38X55X8	Oil Seal	TCØ38xØ55x8	1
62	50-0137	Gear Shaft		1
63	KY038X8X25	Double Round Head Key	8x8x25L	1
64	50-0138	Gear		1
65	50-0139	Washer		1
66	50-0130	Plug		2
67	OR01P46	O-Ring	P46	1



No.	Part No.	Name	Specification	Qty.
69	50-0160	Pulley		1
70	WR07AW05	Bearing Locking Washer	AW05	1
71	60-0128	Shaft		1
72	SW14M8X12L	Socket Head Set Screw	M8xP1.25x12L	1
73	OR01P24	O-Ring	P24	2
74	RR01STW25	Retaining Ring (External)	STW#25	1
75	60-0129	Gear		1
76	60-0130	Shaft		1
77	RB6205	Deep Groove Ball Bearing	#6205	2
78	RR01STW30	Retaining Ring (External)	STW#30	2
79	60-0131	Gear		1
80	60-0132	Gear		1
81	KY037X7X25	Double Round Head Key	7x7x25L	1
82	RR01STW40	Retaining Ring (External)	STW#40	1
83	60-0133	Gear		1
84	60-0134	Shaft		1
85	RB6205	Deep Groove Ball Bearing	#6205	1
86	KY035X5X30L	Double Round Head Key	10x8x30L	1
87	KY037X7X60L	Double Round Head Key	7x7x60L	1
88	RR01STW25	Retaining Ring (External)	STW#25	1
89	RR01STW30	Retaining Ring (External)	STW#30	1
90	60-0135	Bearing Cover		1
91	SW02M6X16L	Socket Head Cap Screw	M6xP1.0x16L	3
92	OSTC35X48X8	Oil Seal	TCØ35xØ48x8	1
93	RBTLA30X37X20	Needle Bearing	#TLA30x37x20	2
94	10-0276	Washer		2
95	60-0136	Gear		1
96	60-0137	Gear		1
97	62-0138A	Bearing Cover		1
98	SW02M6X12L	Socket Head Cap Screw	M6xP1.0x12L	3
99	50-0130	Plug		1
100	SW14M8X12L	Socket Head Set Screw	M6xP1.0x12L	1
101	50-0153	Bushing		2
102	50-1132	Washer		1
103	60-0164	Packing		1



No.	Part No.	Name	Specification	Qty.
104	60-0167	Packing		1
105	60-0168	Packing		1
106	50-01143	Balancing Block		1
107	SW14M8X8L	Socket Head Set Screw	M8xP1.25x8L	2
108	50-01144	Balancing Block		3
109	SW14M6X8L	Socket Head Set Screw	M6xP1.0x8L	6
110	50-01161	Bushing		1
111	50-0122	Spacer		1
112	OR01P46	O-Ring	P46	1
115	62-0139A	Shaft		2
116	OR01P46	O-Ring	P12	5
117	KY035X5X15L	Double Round Head Key	5X5X15L	5
118	PN03Ø5X30L	Spring Pin	Ø5x30L	2
119	SW14M5X20L	Socket Head Set Screw	M5xP0.8x20L	5
120	60-0140	Speed Changing Sleeve		2
121	SW08M5X20L	Socket Head Set Screw	M5xP0.8x20L	10
122	OR01P24	O-Ring	P24	5
123	60-0141	Shifting Arm		2
124	60-0142	Shifting Fork		2
125	60-0144	Speed Changing Sleeve		3
126	62-0147A	Shaft		2
127	17-0629	Plug		6
128	62-0148	Shifting Arm		3
129	62-0150	Shaft		1
130	62-0152	Quadrant Gear		1
131	PN03Ø5X30L	Spring Pin	Ø5X30L	6
132	62-0153A	Shaft		1
133	SW14M8X8L	Socket Head Set Screw	M8xP1.25x8L	3
134	SB01Ø1/4"	Steel Ball	Ø1/4	3
135	62-0154	Shifting Fork		2
136	62-0156A	Head Stock Cover		1
137	SW02M8X20L	Socket Head Cap Screw	M8xP1.25x20L	6
138	62-0155A	Packing		1
139	62-0150	Shaft		2
140	60-0152	Quadrant Gear		2



No.	Part No.	Name	Specification	Qty.
141	50-0164	Feed Selector Knob		2
142	50-0165	Shifting Lever		2
143	50-01138	Knob		2
144	50-0166	Knob		1
145	5-0167	Washer		5
146	17-0504	Screw		5
147	50-0180	Feed Selector Knob		2
148	SW14M8X8L	Socket Head Cap Screw	M8xP1.25x8L	5
149	SG02Ø6X30L	Spring	Ø6XØ0.8x30L	5
150	SB01Ø1/4"	Steel Ball	Ø1/4	5
151	50-0189	Speed Changing Disk		1
152	50-0191	Changing Block		1
153	50-0192	Lever		1
154	PN03Ø4X20L	Spring Pin	Ø4X20L	1
155	50-0199	Shifting Block		1
160	17-0172	Drain Plug		1
161	17-0173	Elbow		1
162	17-0174	Plug		1
163	50-01146	Oil Sight Glass	HE#30	1
164	62-0160A	Indicator		1
165	SW22M4X8L	Socket Head Cap Screw	M4xP0.7x8L	8
166	50-0168	Indicator		2
167	50-0181	Indicator		2
168	62-0190	Indicator		1
169	50-01110	Cam		6
170	50-01111	Detent Spring		6
171	50-01112	Detent Screw		6
172	50-01113	Aligning Pin		1
173	50-01114	Regulating Block		1
174	SW02M12X55L	Socket Head Cap Screw	M12XP1.75x55L	1
175	SW01M12X20L	Socket Head Cap Screw	M12xP1.75x20L	2
176	50-01115	Key Grip		1
177	50-01116	Cam Drive Key		1
178	50-01117	Center Sleeve		1
179	50-01118	Center		1



No.	Part No.	Name	Specification	Qty.
180	50-01119	Cam Lock Stud		6
181	SW02W5/16X16	Socket Head Cap Screw	W5/16-18UNCx16L	6
182	50-01120A	Driving Plate		1
183	17-0176	Driving Collar		1
184	SW02M12X25L	Socket Head Cap Screw	M12xP1.75x25L	1
185	50-01120B-00	Drive Plate		1
186	SW02M12X45L	Socket Head Cap Screw	M12xP1.75x45L	4
187	50-01129	Driving Pin		1
188	50-01133	Driving Pin		1



GEARBOX ASSEMBLY 1/4

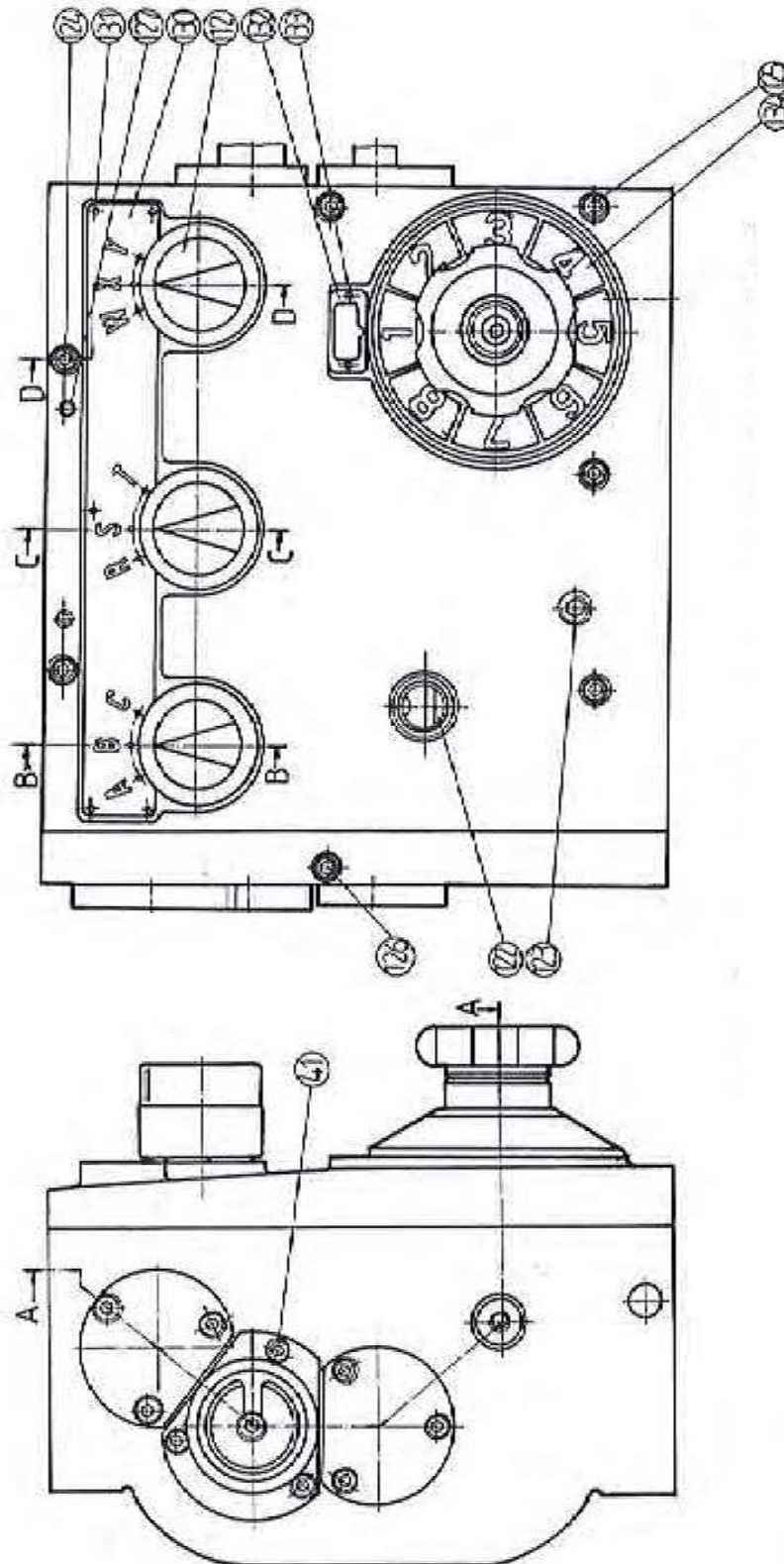



GEARBOX ASSEMBLY 2/4

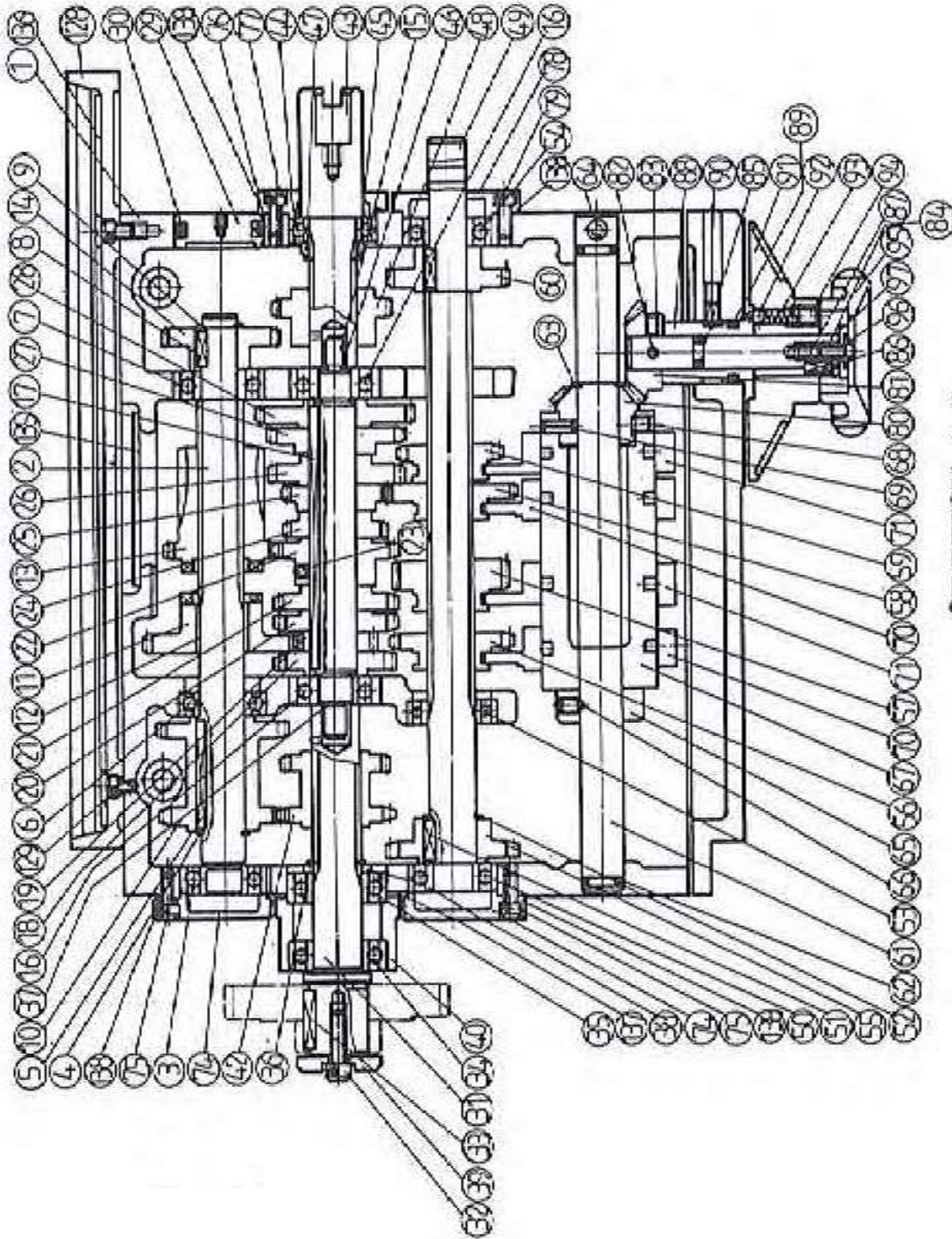

SECTION-A-A



GEARBOX ASSEMBLY 3/4

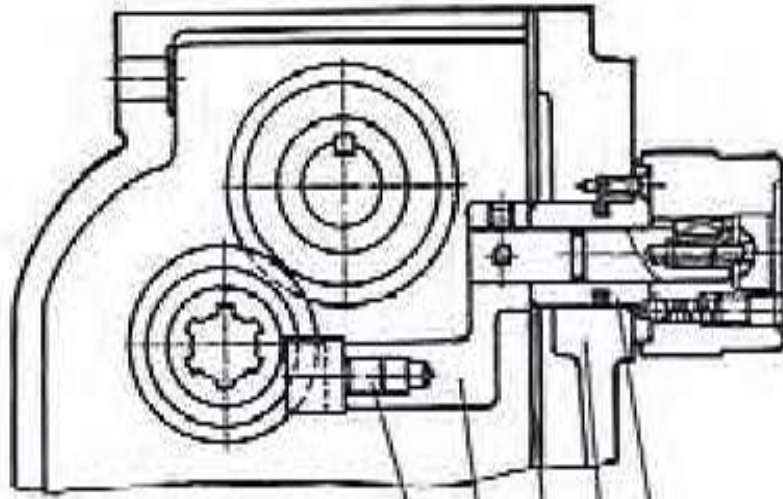

SECTION: B-B

- 114
- 113
- 119
- 121
- 109

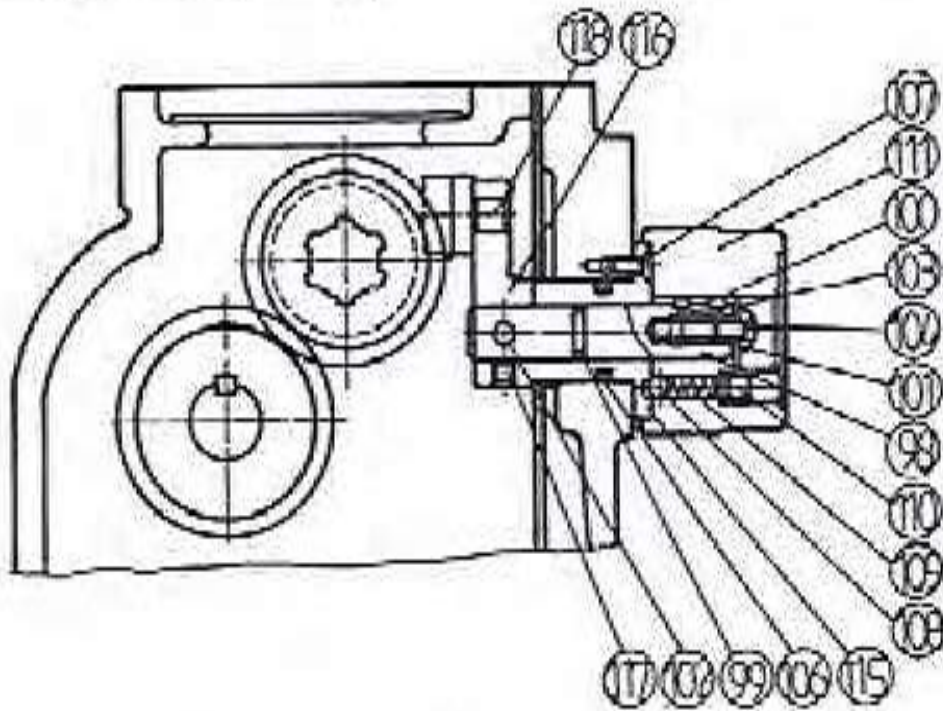

SECTION: C-C

- 118
- 116
- 107
- 111
- 100
- 103
- 102
- 101
- 99
- 110
- 109
- 108
- 117
- 102
- 99
- 106
- 115



GEARBOX ASSEMBLY 4/4

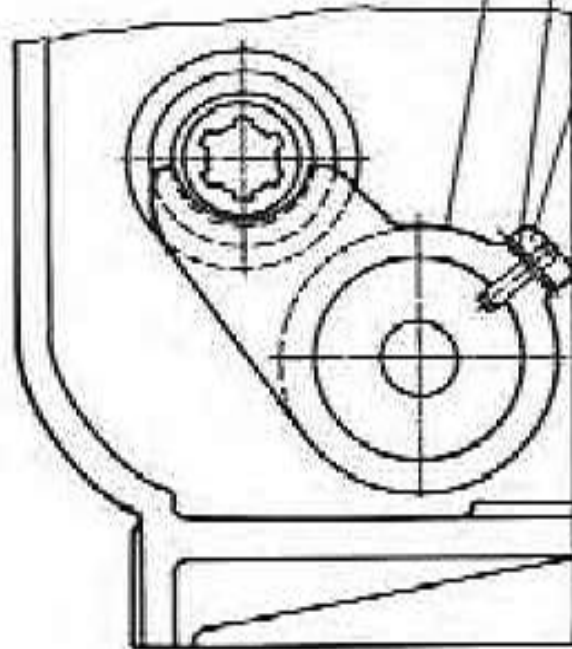
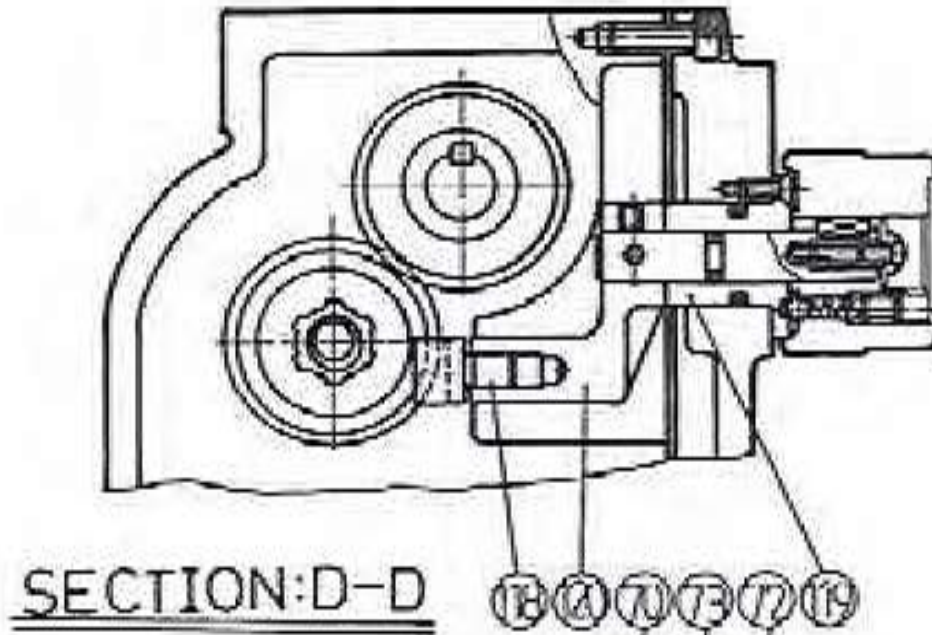

SECTION: E-E



GEARBOX PARTS IDENTIFICATION

No.	Part No.	Name	Specification	Qty.
1	60-0201-00	Gear Box Casting		1
2	60-0202-00	Input Shaft		1
3	RB6204	Deep Groove Ball Bearing	#6204	1
4	RR01STW25	Retaining Ring (External)	STW#25	1
5	KY036X6X55	Double Round Head Key	6x6x55L	1
6	RB6005	Deep Groove Ball Bearing	#6005	1
7	RB6204	Deep Groove Ball Bearing	#6204	1
8	KY036X6X18	Double Round Head Key	6x6x18L	1
9	RR01STW20	Retaining Ring (External)	STW#20	1
10	60-0203-00	Gear	M2.5x23T,M3x19T	1
11	60-0204-00	Clutch Gear	M2x38T	1
12	MB2525DU	Dry Bearing	Ø25xØ28x25	1
13	60-0205-00	Clutch Gear	M2.5x23T,M2x19T	1
14	60-0206-00	Gear	M1.75x35T	1
15	60-0207-00	Shaft		1
16	RB6303	Deep Groove Ball Bearing	#6303	2
17	KY036X6X135	Double Round Head Key	6x6x135L	1
18	60-0208-00	Gear	M2.75x22T	1
19	60-0209-00	Gear	M2x19T	1
20	60-0210-00	Gear	M2.75x20T	1
21	60-0211-00	Gear	M2.5x24T	1
22	60-0212-00	Gear	M2.5x23T	1
23	SW14M6X6	Socket Head Set Screw	M6xP1.0x6L	1
24	60-0213-00	Gear	M2x27T	1
25	60-0214-00	Gear	M2x24T	1
26	60-0215-00	Gear	M2.5x28T	1
27	60-0216-00	Gear	M2.5x26T	1
28	60-0217-00	Gear	M2x38T	1
29	17-0120-00	Plug		1
30	OR02G40	O-Ring	G40x3.1	1
31	60-0218-00	Input Shaft		1
32	SW02M8X25	Socket Head Cap Screw	M8xP1.25x25L	1
33	KY036X6X30	Double Round Head Key	6x6x30L	1



No.	Part No.	Name	Specification	Qty.
34	RB6205/2RS1	Deep Groove Ball Bearing	#6205-2RS1	1
35	RB6205	Deep Groove Ball Bearing	#6205	1
36	RR01STW25	Retaining Ring (External)	STW#25	2
37	MB1215DU	Dry Bearing	Ø12xØ14x15L	1
38	50-0414-00	Spacer		1
39	50-0207-00	Washer		1
40	60-0219-00	Bearing Cover		1
41	SW02M6X10	Socket Head Cap Screw	M6xP1.0x10L	3
42	60-0220-00	Gear	M3x19T,M2.5x20T	1
43	60-0221-00	Shaft		1
44	RB6006/2RS1	Deep Groove Ball Bearing	#6005/2RS1	1
45	RR01STW25	Retaining Ring (External)	STW#25	1
46	MB1215DU	Dry Bearing	Ø12xØ14x15L	1
47	50-0222-00	Spacer		1
48	60-0223-00	Gear	M1.75x35T	1
49	60-0224-00	Input Shaft		1
50	RB6204	Deep Groove Ball Bearing	#6204	1
51	KY036X6X20	Double Round Head Key	6x6x20L	1
52	RR01STW25	Retaining Ring (External)	STW#25	1
53	RB6005	Deep Groove Ball Bearing	#6005	1
54	RB6204/2RS1	Deep Groove Ball Bearing	#6204/2RS1	1
55	60-0225-00	Gear	M3x22T	1
56	60-0226-00	Gear	M2.75x22T	1
57	60-0227-00	Gear	M2.5x22T	1
58	60-0228-00	Gear	M2x33T	1
59	60-0229-00	Gear	M2.5x22T	1
60	60-0230-00	Gear	M1.75x36T	1
61	60-0231-00	Shaft		1
62	OR01P18	O-Ring	P18	2
63	RR01STW22	Retaining Ring (External)	STW#22	1
64	SW14M8X10	Socket Head Set Screw	M8xP1.25x10L	1
65	50-0251-00	Collar		1
66	SW16M8X10	Socket Head Set Screw	M8xP1.25x10L	1
67	60-0232	Cam		1
68	SW14M8X8	Socket Head Set Screw	M8xP1.25x8L	1



No.	Part No.	Name	Specification	Qty.
69	PN03Ø5X16	Spring Pin	Ø5X16L	1
70	60-0233-00	Shifting Fork		2
71	60-0234-00	Shifting Fork		2
72	50-0253-00-1	Pin	Ø6x26L	4
73	PN06Ø25X30	Split Pin	Ø25X30L	4
74	60-0235-00	Bearing Cover		2
75	SW02M6X12	Socket Head Cap Screw	M6xP1.0x12L	6
76	60-0236-00	Bearing Cover		1
77	SW02M6X16	Socket Head Cap Screw	M6xP1.0x16L	3
78	60-0237-00	Bearing Cover		1
79	SW02M6X16	Socket Head Cap Screw	M6xP1.0x16L	3
80	50-0257-00	Bevel Gear	M2x24T	1
81	50-0258-00	Bevel Gear	M2x24T	1
82	PN03Ø5X36	Spring Pin	Ø5x36L	1
83	SW14M6X8	Socket Head Set Screw	M6xP1.0x8L	1
84	60-0238-00	Shaft		1
85	OR01P12	O-Ring	P12	1
86	KY035X5X15	Double Round Head Key	5x5x15L	1
87	SW14M5X20	Socket Head Set Screw	M5xP0.5x20L	1
88	60-0239-00	Sleeve		1
89	OR01P24	O-Ring	P24	1
90	SW14M8X10	Socket Head Set Screw	M8xP1.25x10L	1
91	50-0262-00	Speed Changing Disk		1
92	SB01Ø1/4"	Steel Ball	Ø1/4"	1
93	SG02Ø6XØ0.5X30	Compression Spring	Ø6xØ0.5x30L	1
94	SW14M8X10	Socket Head Set Screw	M8xP1.25x10L	1
95	50-0264-00	Changing Knob		1
96	17-0504-2	Socket Button Head Screw	M8xP1.25x20L	1
97	50-0288-00	Washer		1
98	60-0240-00	Shaft		3
99	OR01P12	O-Ring	P12	3
100	KY035X5X15	Double Round Head Key	5x5x15L	3
101	SW14M5X20	Socket Head Set Screw	M5xP0.8x20L	3
102	PN03Ø5X30	Spring Pin	Ø5x30L	3
103	50-0167-00	Washer		3



104	17-0504-2	Socket Button Head Screw	M8xP1.25x20L	3
105	60-0241-00	Sleeve		1
106	OR01P24	O-Ring	P24	3
107	SW08M5X12	Counter Sunk Flat Screw		6
108	SB01Ø1/4"	Steel Ball	Ø1/4"	3
109	SG02Ø6XØ0.5X30	Compression Spring	Ø6XØ0.5X30L	3
110	SW14M8X10	Socket Head Set Screw	M8xP1.25x10L	3
111	50-0180-01	Feed Selector Knob		3
112	50-0181-00	Indicator		3
113	60-0242-00	Shifting Arm		1
114	60-0243-00	Shifting Block		1
115	60-0244-00	Sleeve		1
116	60-0245-00	Shifting Arm		1
117	SW14M6X8	Socket Head Set Screw	M6xP1.0x8L	3
118	60-0246-00	Shifting Block		2
119	60-0247-00	Sleeve		1
120	60-0248-00	Shifting Arm		1
121	60-0249-00	Gear Box Front Cover		1
122	50-01145-00	Oil Sight Glass	HE#30	1
123	60-0249-00-2	Drain Plug	PT 3/8"	1
124	SW02M8X20	Socket Head Cap Screw	M8xP1.25x20L	2
125	SW02M8X30	Socket Head Cap Screw	M8xP1.25x30L	4
126	SW02M8X16	Socket Head Cap Screw	M8xP1.25x16L	1
127	PN03Ø6X30	Spring Pin	Ø6x30L	2
128	60-0251-00	Upper Cover		1
129	SW02M6X10	Socket Head Cap Screw	M6xP1.0x10L	2
130	60-0252-00	A-B-C Indicator		1
131	RT01Ø2X5	Button Head Rivet	Ø2x5L	5
132	50-0283-00	Indicator		1
133	RT01Ø2X5	Button Head Rivet	Ø2x5L	2
134	60-0253-00	Indicator		1
135	60-0256-00	Plate		1
136	60-0257-00	Rubber Pad		1
137	60-0258-00	Packing		1
138	60-0259-00	Packing		4
139	60-0260-00	Packing		1



CARRIAGE ASSEMBLY 1/7

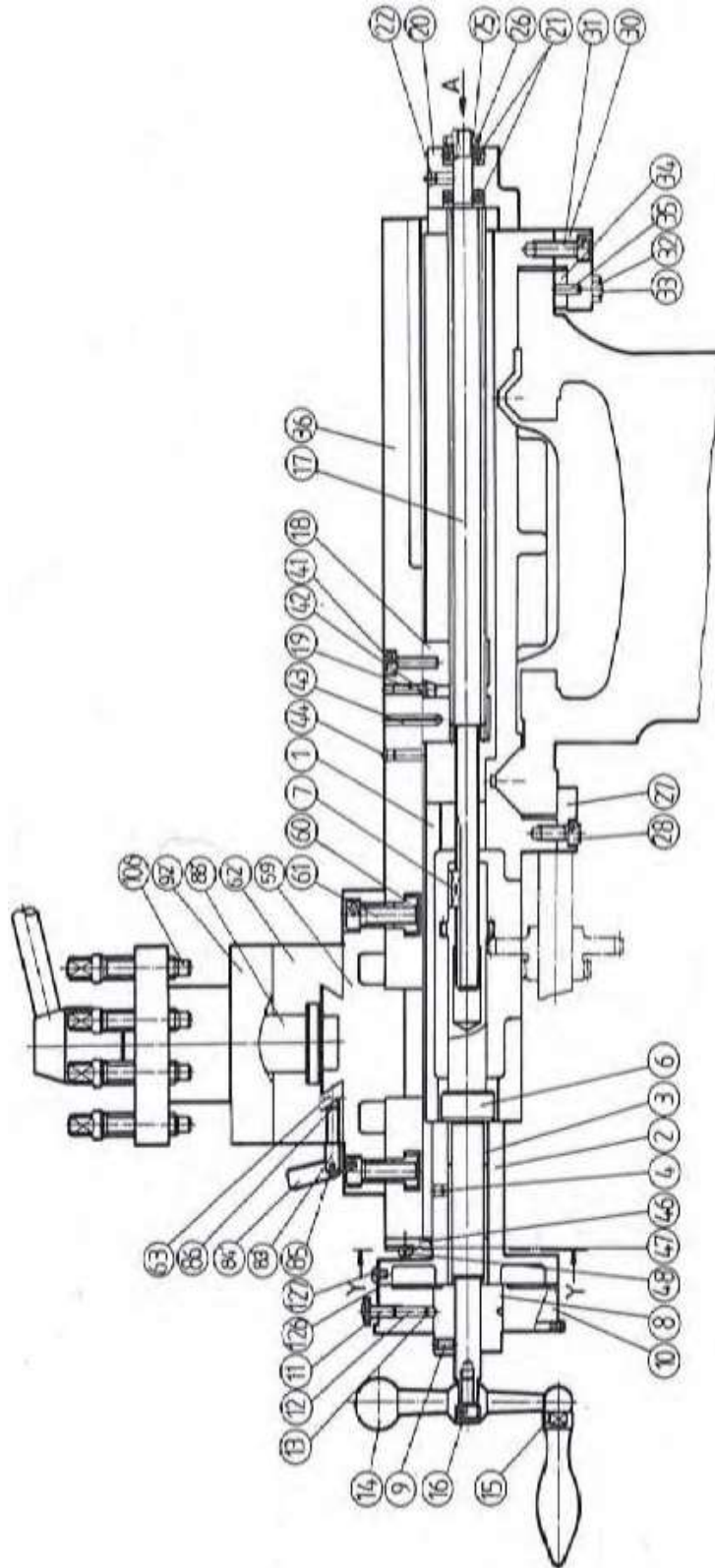



CARRIAGE ASSEMBLY 2/7

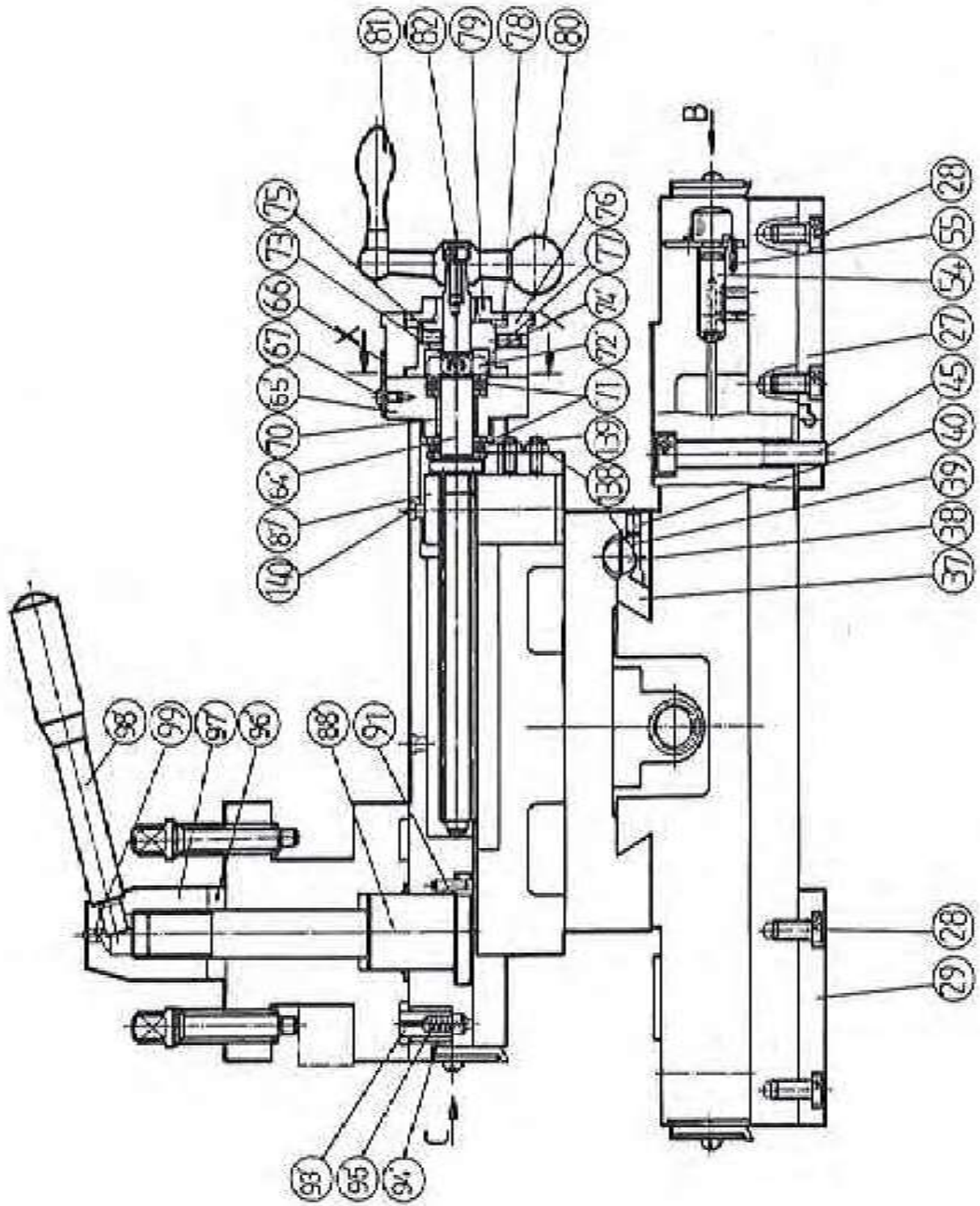



CARRIAGE ASSEMBLY 3/7

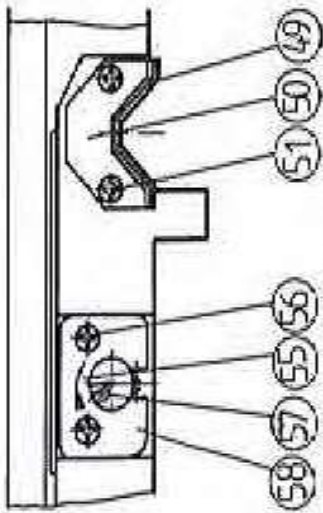

VIEW OF ARROW: B

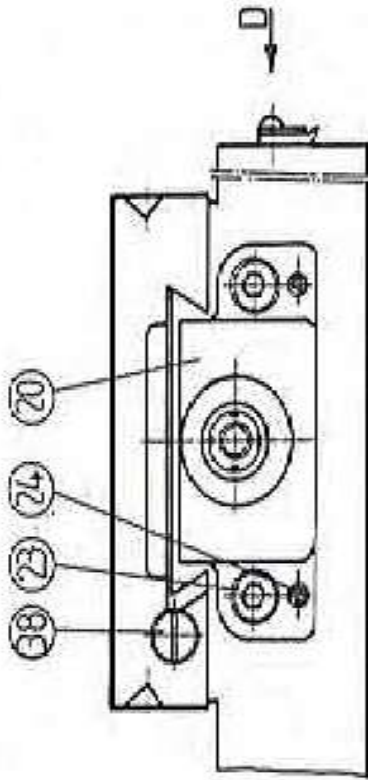

VIEW OF ARROW: A

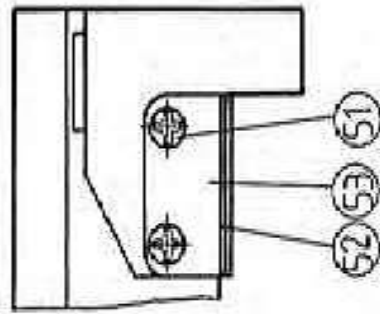

VIEW OF ARROW: D

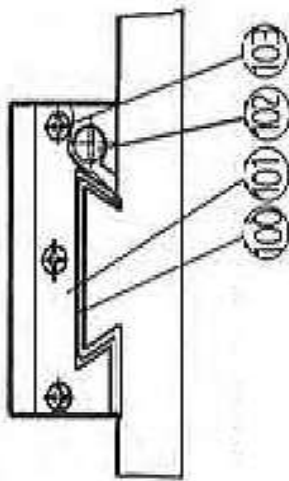

VIEW OF ARROW: C

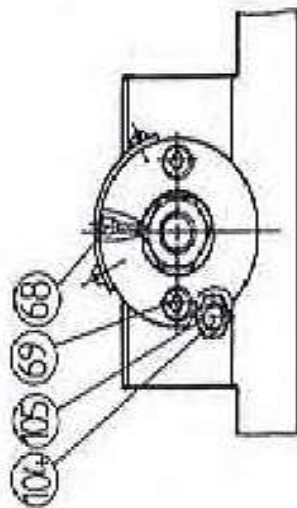

SECTION: X-X

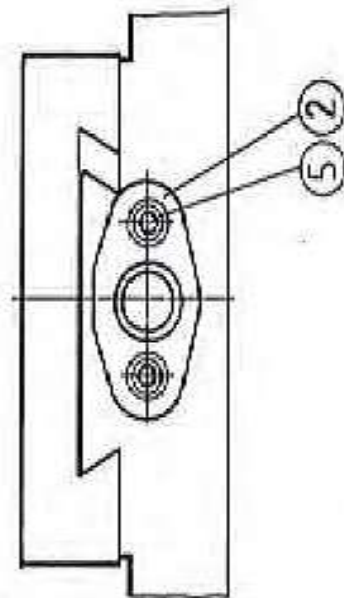

VIEW OF ARROW: Y



CARRIAGE ASSEMBLY 4/7

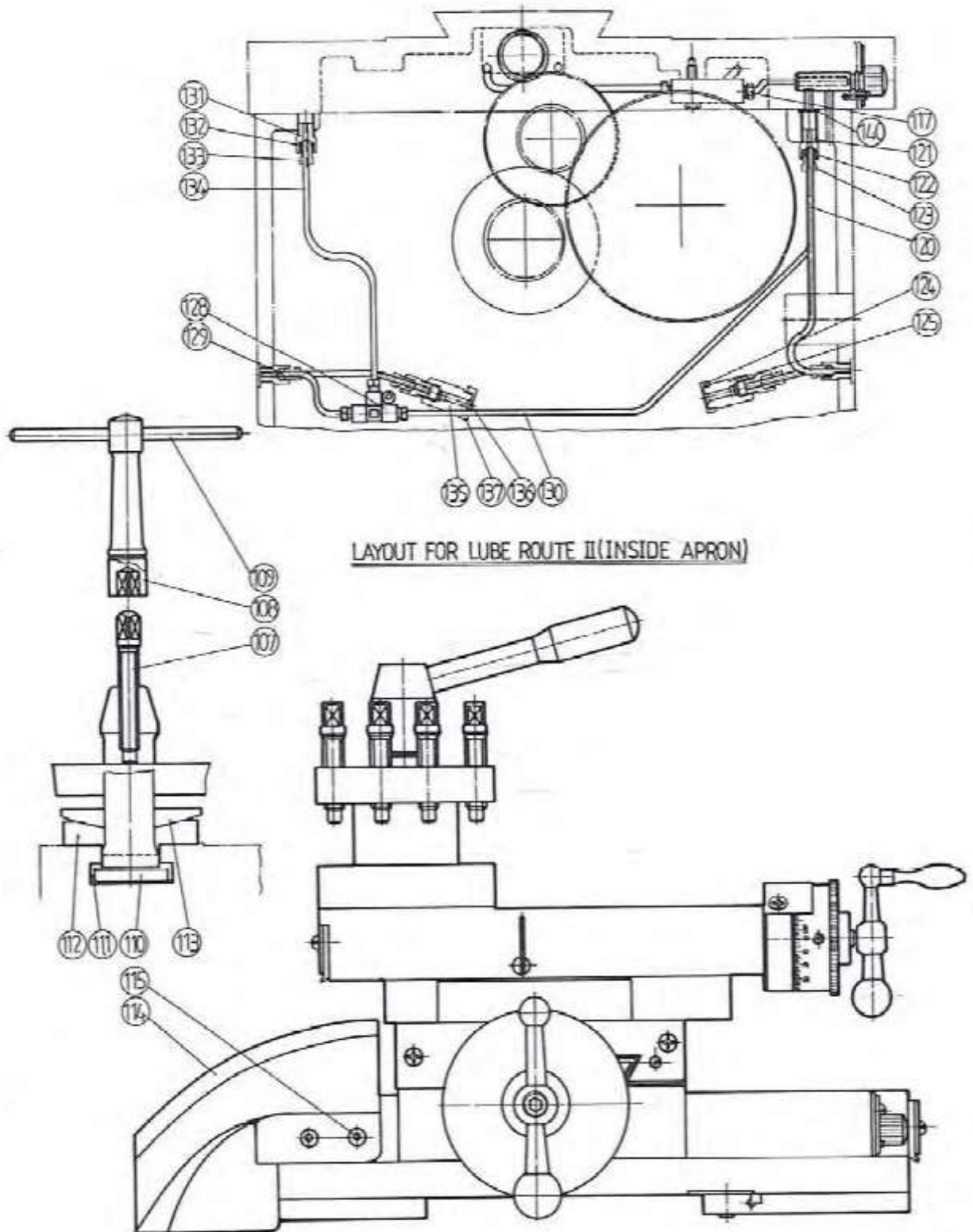



CARRIAGE ASSEMBLY 5/7

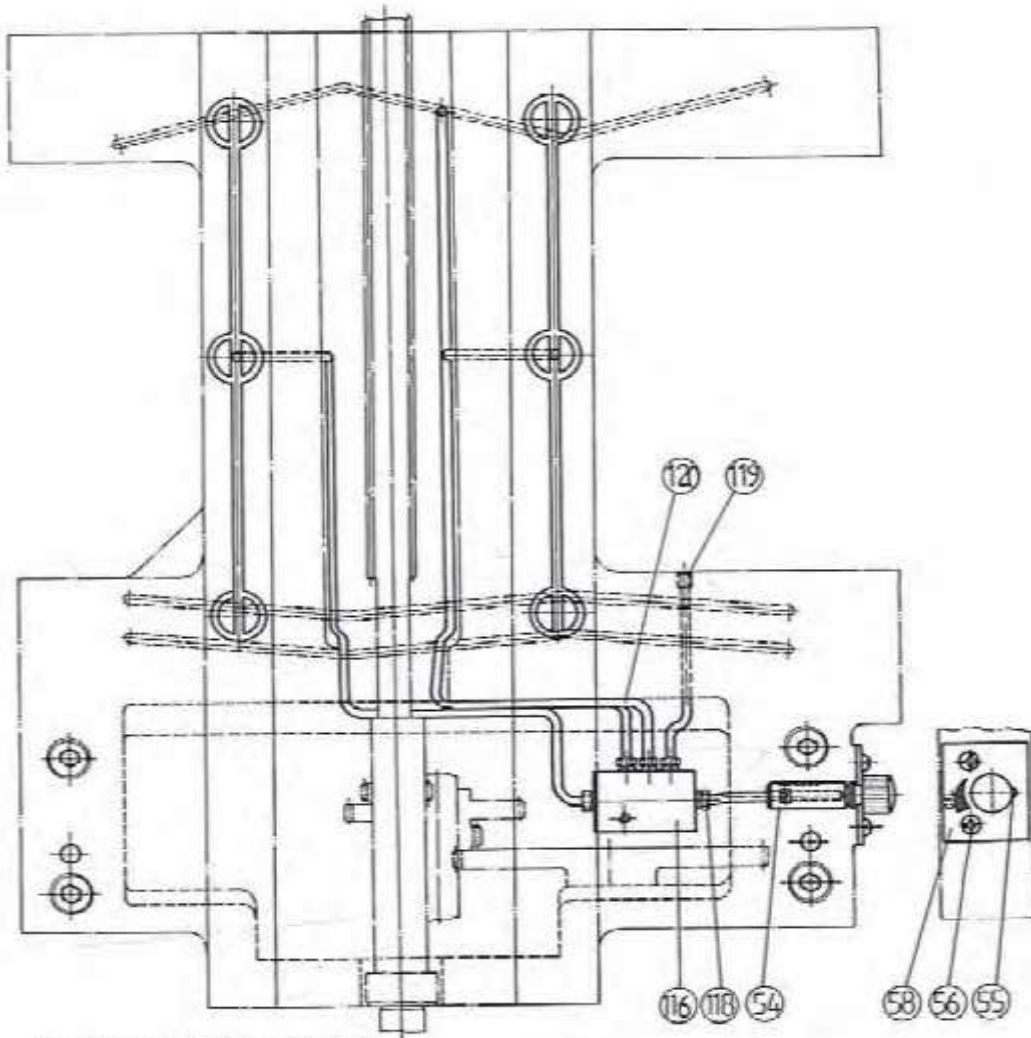

LAYOUT FOR LUBE ROUTE I

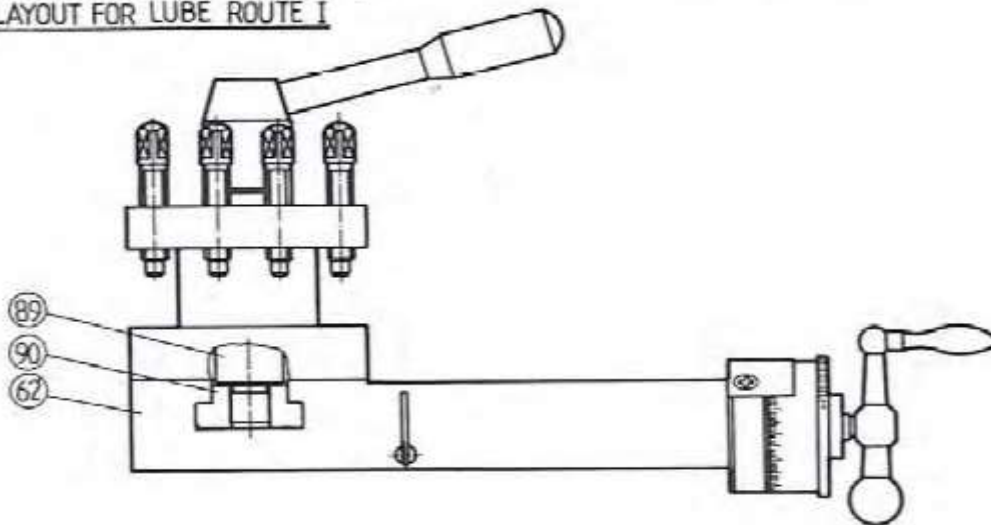



CARRIAGE ASSEMBLY 6/7

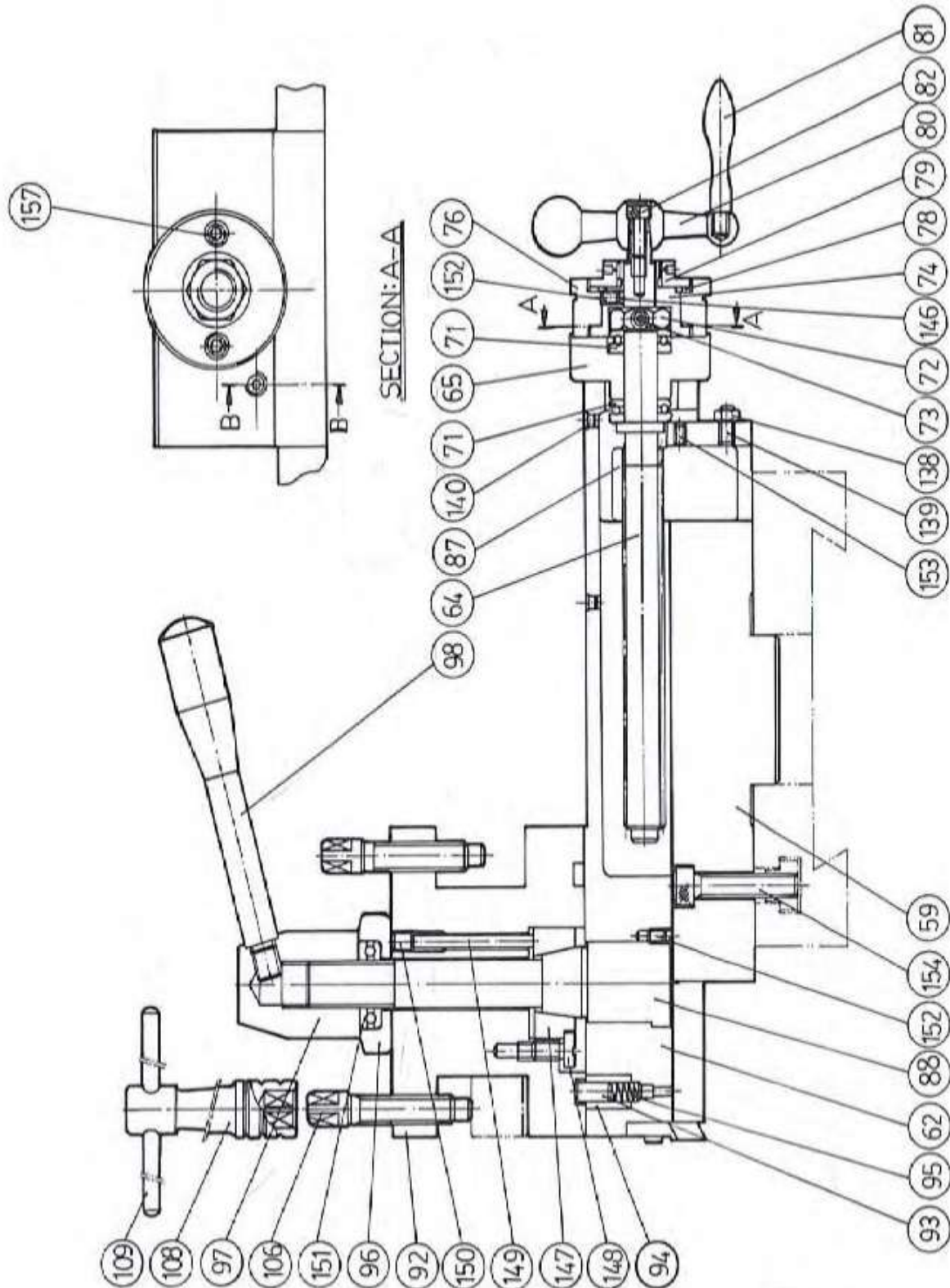



CARRIAGE ASSEMBLY 7/7

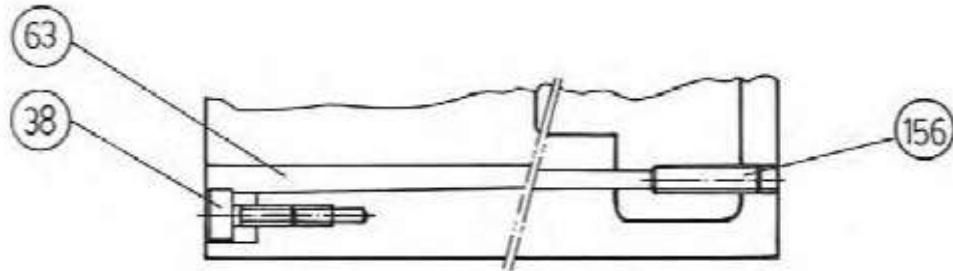

SECTION: B-B

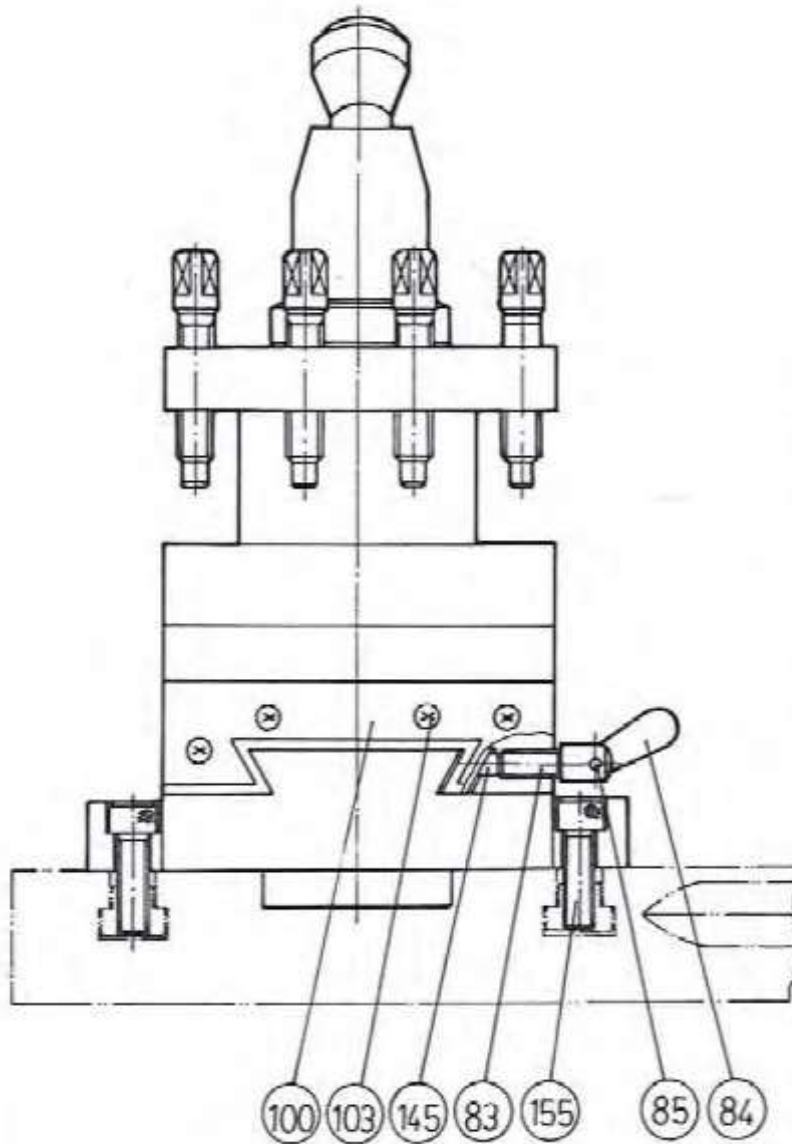



CARRIAGE PARTS IDENTIFICATION

No.	Part No.	Name	Specification	Qty.
1	60-0301-00	Saddle		1
2	50-0304-01	Bracket		1
3	50-0305-00	Oilite Bushing		2
4	OC01Ø1/4"	Ball Cup	Ø1/4"	1
5	SW02M8X55	Socket Head Cap Screw	M8xP1.25x55L	2
6	60-0306-00	Pinion Shaft		1
7	KY035X5X20	Double Round Head Key	5x5x20L	1
8	50-0307-01	Sleeve		1
9	SW14M6X12	Socket Head Set Screw	M6xP1.0x12L	1
10	50-0308B-01	Dial	(Metric)	1
10	50-0309B-01	Dial	(Imperial)	1
11	50-03111-00	Screw		1
12	60-03109-00	Pad Piece	Ø5x20L	1
13	SB01Ø5	Steel Ball	Ø5	1
14	50-0313-00	Handle		1
15	50-0314-01	Grip		1
16	SW02M8X16	Socket Head Cap Screw	M8xP1.25x16L	1
17	60-0316-1/2-00	Cross Feed Screw	(Metric)	1
17	60-0316-2/2-00	Cross Feed Screw	(Imperial)	1
18	60-0317-00	Cross Feed Nut	(Metric)	1
18	60-0317B-00	Cross Feed Nut	(Imperial)	1
19	17-0325-00	Adjusting Block		1
20	60-0319-00	Bracket		1
21	RB51101	Thrust Bearing	#51101	2
22	OC01Ø1/4"	Ball Cup	Ø1/4"	1
23	SW02M10X30	Socket Head Cap Screw	M10xP1.5x30L	2
24	PN05#5X30	Taper Pin w/Internal Thread	#5x30L	2
25	84-0028-01	Locking Nut	FAG MB1	1
26	WR07MB1	Lock Washer	FAG MB1	1
27	60-0322-00	Strip	(Front)	1
28	SW02MX16	Socket Head Cap Screw	M8xP1.25x16L	4
29	60-03108-00	Strip	(Front)	1
30	60-0323-00	Strip	(Rear)	1



No.	Part No.	Name	Specification	Qty.
31	SW02M8X26	Socket Head Cap Screw	M8xP1.25x26L	4
32	NT01M8	Hex Nut	M8	4
33	SW14M8X22	Socket Head Set Screw	M8xP1.25x22L	4
34	60-0324-00	Bottom Plate	(Optional)	2
35	PN01Ø5X16	Pin	Ø5X16L	4
36	60-0326-00	Cross Slide		1
37	50-0327-00	Taper Gib Strip		1
38	50-0325-00	Adjusting Screw		2
39	50-0366-00	Thrust Pad		1
40	SW14M8X12	Socket Head Set Screw	M8xP1.25x12L	1
41	SW02M6X26	Socket Head Cap Screw	M6xP1.0x26L	4
42	SW14M6X20	Socket Head Set Screw	M6xP1.0x20L	1
43	PN03Ø6X32	Spring Pin	Ø6X32L	1
44	OC01Ø1/4"	Ball Cup	Ø1/4"	1
45	SW02M10X70	Socket Head Cap Screw	M10xP1.5x70L	1
46	60-0327-1/2-00	Wiper		1
47	60-0327-2/2-00	Wiper Plate		1
48	SW04M6X12	Cross Recessed Head Screw	M6xP1.0x12L	1
49	50-0360-00	Bed Way Wiper		2
50	50-0361-00	Bed Way Wiper Plate		2
51	SW04M6X12	Cross Recessed Head Screw	M6xP1.0x12L	4
52	50-0362-00	Bed Way Wiper		2
53	50-0363-00	Bed Way Wiper Plate		2
54	60-0358-00	Lube Flow Controller		1
55	PN03Ø4X12	Spring Pin	Ø4X12L	1
56	SW04M5X8	Cross Recessed Head Screw	M5xP0.8x8L	2
57	RT01Ø2X5	Button Head Rivet	Ø2X5L	1
58	50-0359-01	Indicator		1
59	50-0330-00	Swivel Table		1
60	50-0328-00	T-Nut		4
61	SW02M10X35	Socket Head Cap Screw	M10xP1.5x35L	4
62	50-0333B-00	Compound Rest	(Normal)	1
62	50-0333-00	Compound Rest	(T-Slot)	1
63	50-0334-00	Taper Gib Strip		1
64	50-0355-00	Compound Feed Screw	(Metric)	1



No.	Part No.	Name	Specification	Qty.
64	50-0336-00	Compound Feed Screw	(Imperial)	1
65	50-0337-00	Bracket		1
66	17-0355-1/2-00	Compound Dial Guard	(Metric)	1
66	17-0355-2/2-00	Compound Dial Guard	(Imperial)	1
67	SW04M4X8	Cross Recessed Head Screw	M4xP0.7x8L	2
68	OC01Ø1/4"	Ball Cup	Ø1/4"	1
69	SW02M6X20	Socket Head Cap Screw	M6xP1.0x20L	2
70	50-0338-00	Bushing		1
71	RB51102	Thrust Bearing	#51102	2
72	50-0339-00	Nut	M15xP1.5	1
73	SW14M6X6	Socket Head Set Screw	M6xP1.0x6L	1
74	50-0340-00	Sleeve		1
75	SW14M6X10	Socket Head Set Screw	M6xP1.0x10L	1
76	50-0341B-00	Dial	(Metric)	1
76	50-0342B-00	Dial	(Imperial)	1
77	SW14M6X12	Socket Head Set Screw	M6xP1.0x12L	1
78	WR09WW32	Wave Washer (WW#32)	Ø33x.8xØ46	1
79	50-0345-00	Setting Collar		1
80	50-0346-00	Handle		1
81	50-0347-00	Grip		1
82	SW02M6X16	Socket Head Cap Screw	M6xP1.0x16L	1
83	50-0348-00	Locking Screw		1
84	50-0349-00	Wiper Grip		1
85	PN03Ø3X8	Spring Pin	Ø3X8L	1
86	50-03113-00	Setting Pin		1
87	50-0331-00	Compound Feed Nut	(Metric)	1
87	50-0332-00	Compound Feed Nut	(Imperial)	1
88	60-0351B-00	Centering Bolt		1
89	60-0351-00	Centering Bolt	(T-Slot)	1
90	50-0350-00	T-Block	(T-Slot)	1
91	PN03Ø4X16	Spring Pin	Ø4X16L	1
92	50-0352-00	Four Way Tool Post		1
93	50-0353-00	Positioning Pin		1
94	50-0354-00	Bushing		1
95	10-0344-00	Compression Spring		1



No.	Part No.	Name	Specification	Qty.
96	50-0355-00	Washer		1
97	50-0356-00	Clamping Head		1
98	50-0357-00	Clamping Lever		1
99	OC01Ø1/4"	Ball Cup	Ø1/4"	1
100	50-03109-00	Bed Way Wiper		1
101	50-03110-00	Bed Way Wiper Plate		1
102	17-0321-00	Adjusting Screw		1
103	SW04M5X8	Cross Recessed Head Screw	M5xP0.8x8L	3
104	SW14M8X40	Socket Head Set Screw	M8xP1.25x40L	1
105	NT01M8	Hex Nut	M8	1
106	50-0370-00	Tool Post Screw		12
107	50-0391-00	Tool Post Screw	(Optional)	1
108	10-0355-00	Wrench		1
109	10-0356-00	Wrench Handle		1
110	50-0387-00	Single Tool Post (American Style)	(Optional)	1
111	50-0388-00	Setting Plate	(Optional)	1
112	50-0389-00	Bottom Plate	(Optional)	1
113	50-0390-00	Tool Supporting Block	(Optional)	1
114	50-0373-01	Chip Guard		1
115	SW02M6X14	Socket Head Cap Screw	M6xP1.0x14L	2
116	50-03106-01	Distributor		1
117	SW01M5X20	Hex Head Screw	M5xP0.8x20L	1
118	50-04133-00	Thimble Nut		5
119	SW14M6X8	Socket Head Set Screw	M6xP1.0x8L	1
120	50-0401-00-20	Oil Tube	Ø4	2
121	50-04129-00	Straight Joint	PT-1/8"	4
122	50-04134-00	Thimble	Ø4	4
123	50-04133-00	Thimble Nut	Ø4	4
124	50-04131-00	Nut	M14xP1.5	1
125	50-04132-00	Straight Joint	PT-1/8"	1
126	50-0310-00	Cross Dial Guard	(Metric)	1
126	50-0311-00	Cross Dial Guard	(Imperial)	1
127	SW04M5X8	Cross Recessed Head Screw	M5xP0.8x8L	1
128	50-0402-00-17	T-Joint	PT-1/8"	1
129	50-0402-00-18	Oil Tube	Ø4	1



No.	Part No.	Name	Specification	Qty.
130	50-0402-00-19	Oil Tube	Ø4	1
131	50-04132-00	Straight Joint	PT-1/8"	4
132	50-04134-00	Thimble	Ø4	4
133	50-04133-00	Thimble Nut		4
134	50-0402-00-23	Oil Tube	Ø4	1
135	50-04132-00	Straight Joint	PT-1/8"	1
136	50-04130-00	Oil Filter Screen	T:0.2	1
137	50-04131-00	Nut	M14xP1.5	1
138	NT01M6	Hex Nut	M6	2
139	SW14M6X14	Socket Head Set Screw	M6xP1.0x14L	2
140	OC01Ø1/4"	Ball Cup	Ø1/4"	1
141	OR01P14	O-Ring	P14xW2.4	1
145	50-03117S-00	Pad Piece		1
146	50-03112S-00	Pad Piece		1
147	50-03113S-00	Bushing		1
148	50-03114S-00	Adjusting Screw		3
149	50-03115S-00	Adjusting Pin		3
150	SW14M8X10	Socket Head Set Screw	M8xP1.25x10L	3
151	RB51104/ZZ	Thrust Bearing	#51104ZZ	1
152	SW14M6X8	Socket Head Set Screw	M6xP1.0x8L	2
153	SW14M6X10	Socket Head Set Screw	M6xP1.0x10L	1
154	SW02M10X48	Socket Head Cap Screw	M10xP1.5x48L	1
155	SW02M10X32	Socket Head Cap Screw	M10xP1.5x32L	2
156	SW14M8X35	Socket Head Set Screw	M8xP1.25x35L	1
157	SW02M6X25	Socket Head Cap Screw	M6xP1.0x25L	2



APRON ASSEMBLY (Left Hand) 1/5

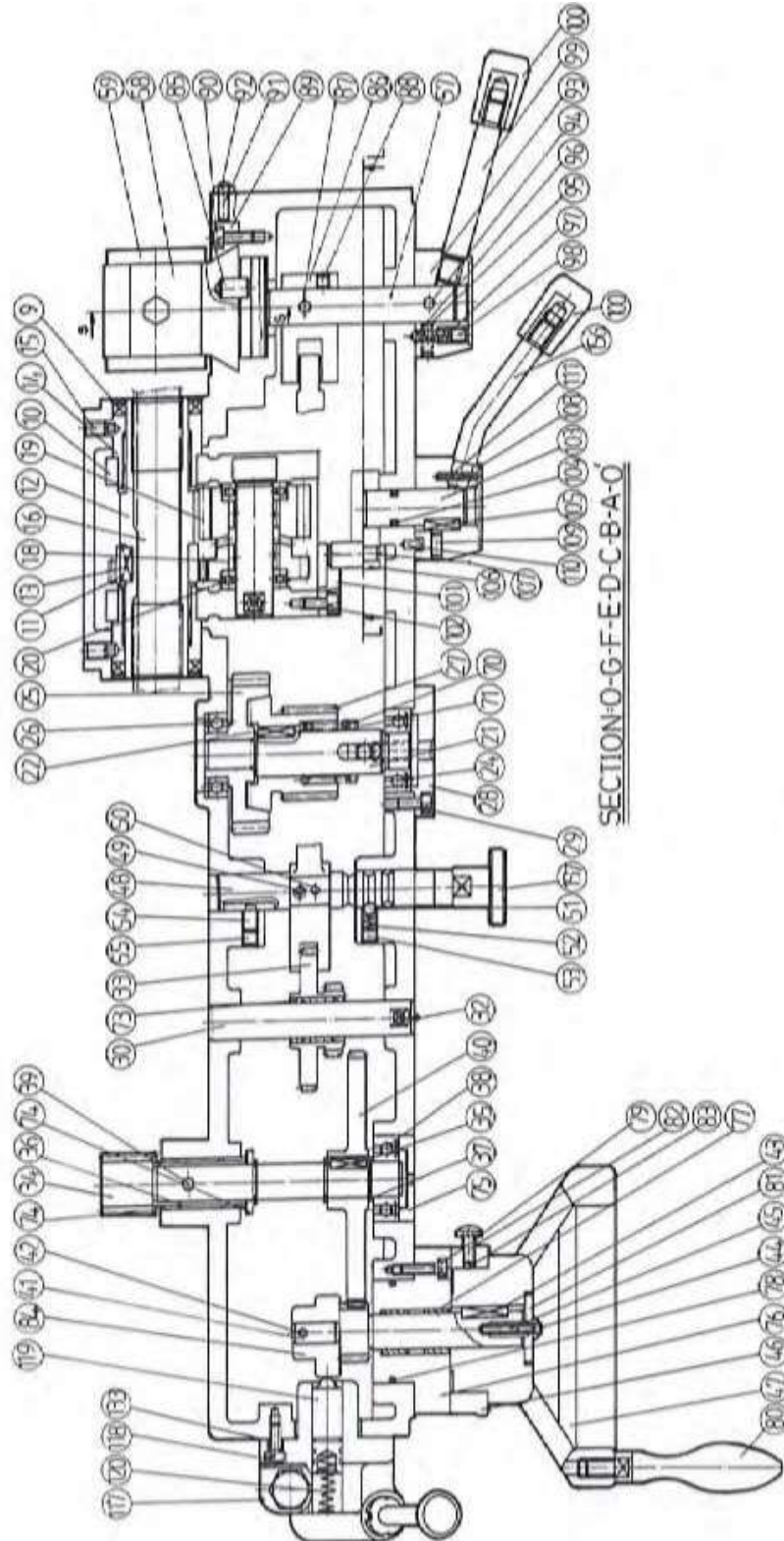



APRON ASSEMBLY (LEFT HAND) 2/5

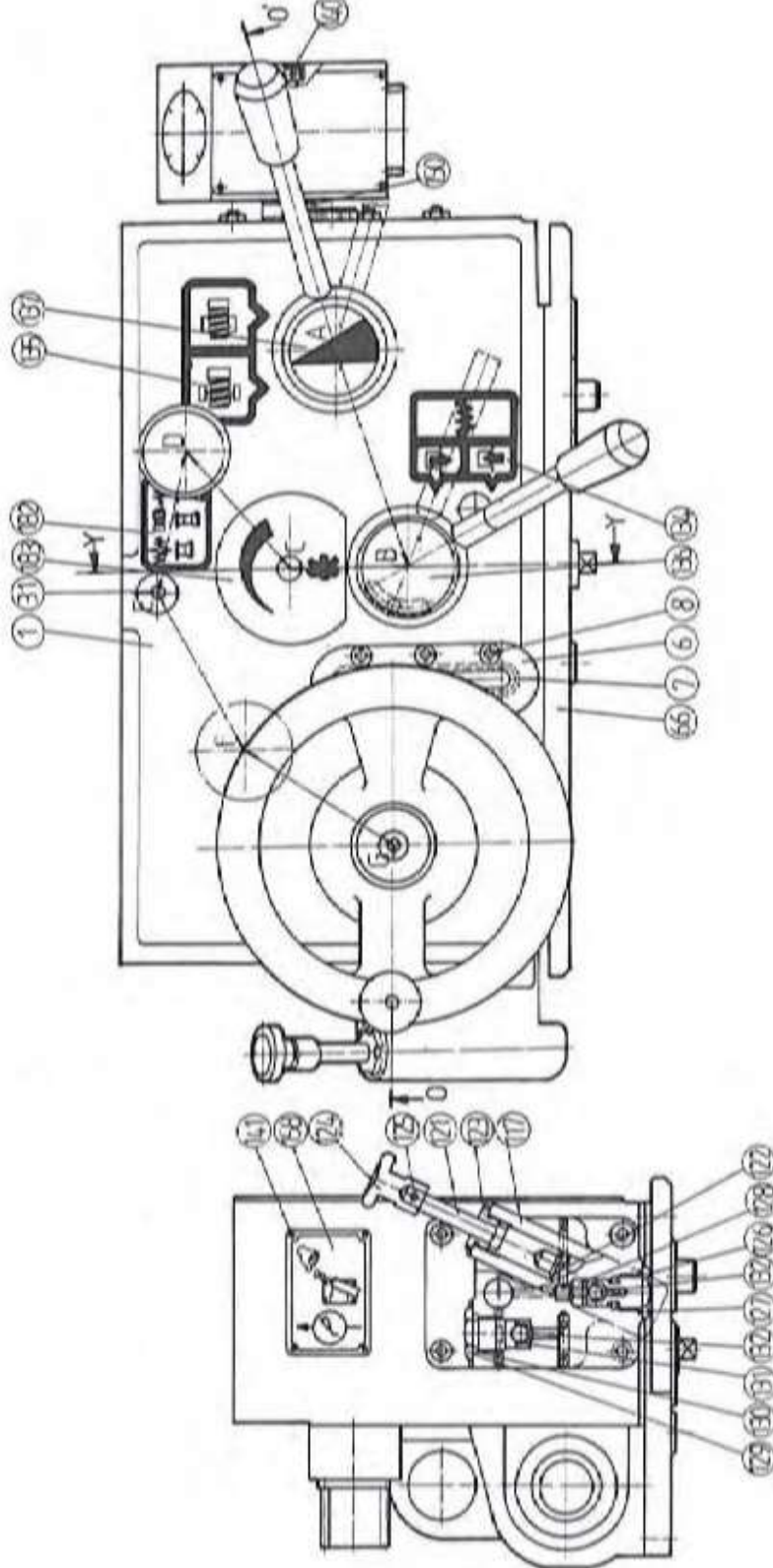



APRON ASSEMBLY (LEFT HAND) 3/5

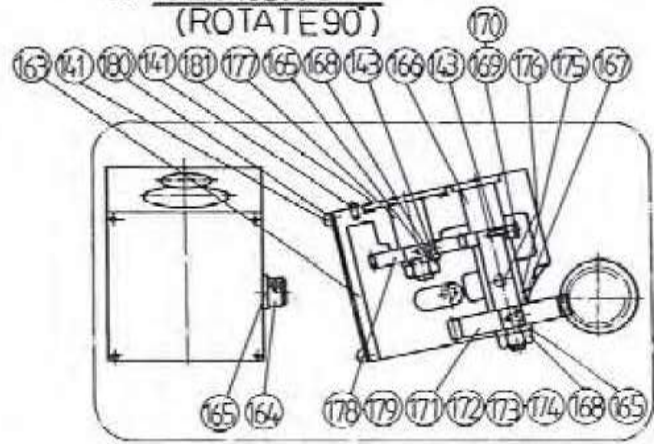
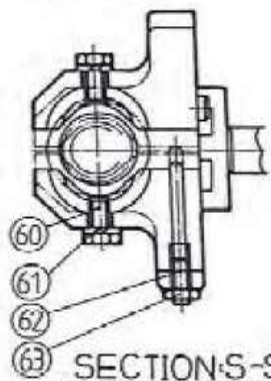
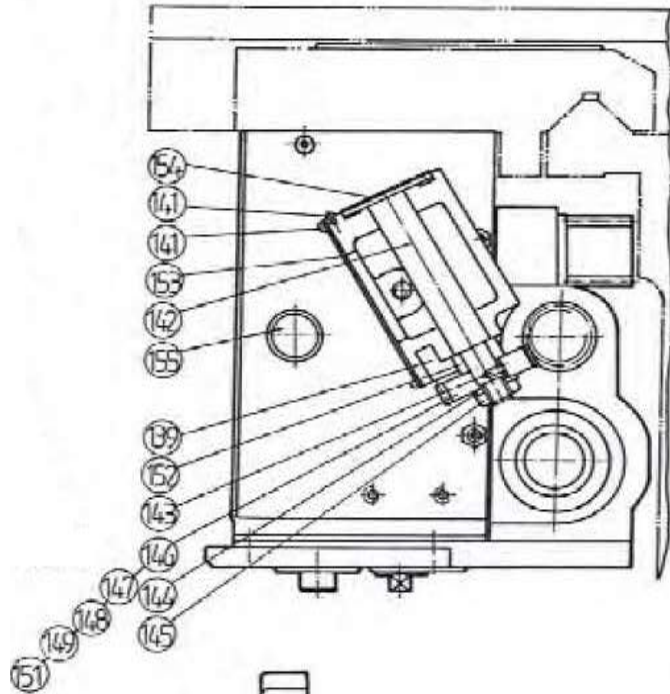

OPTIONAL THREAD
DIAL INDICATOR



APRON ASSEMBLY (LEFT HAND) 4/5

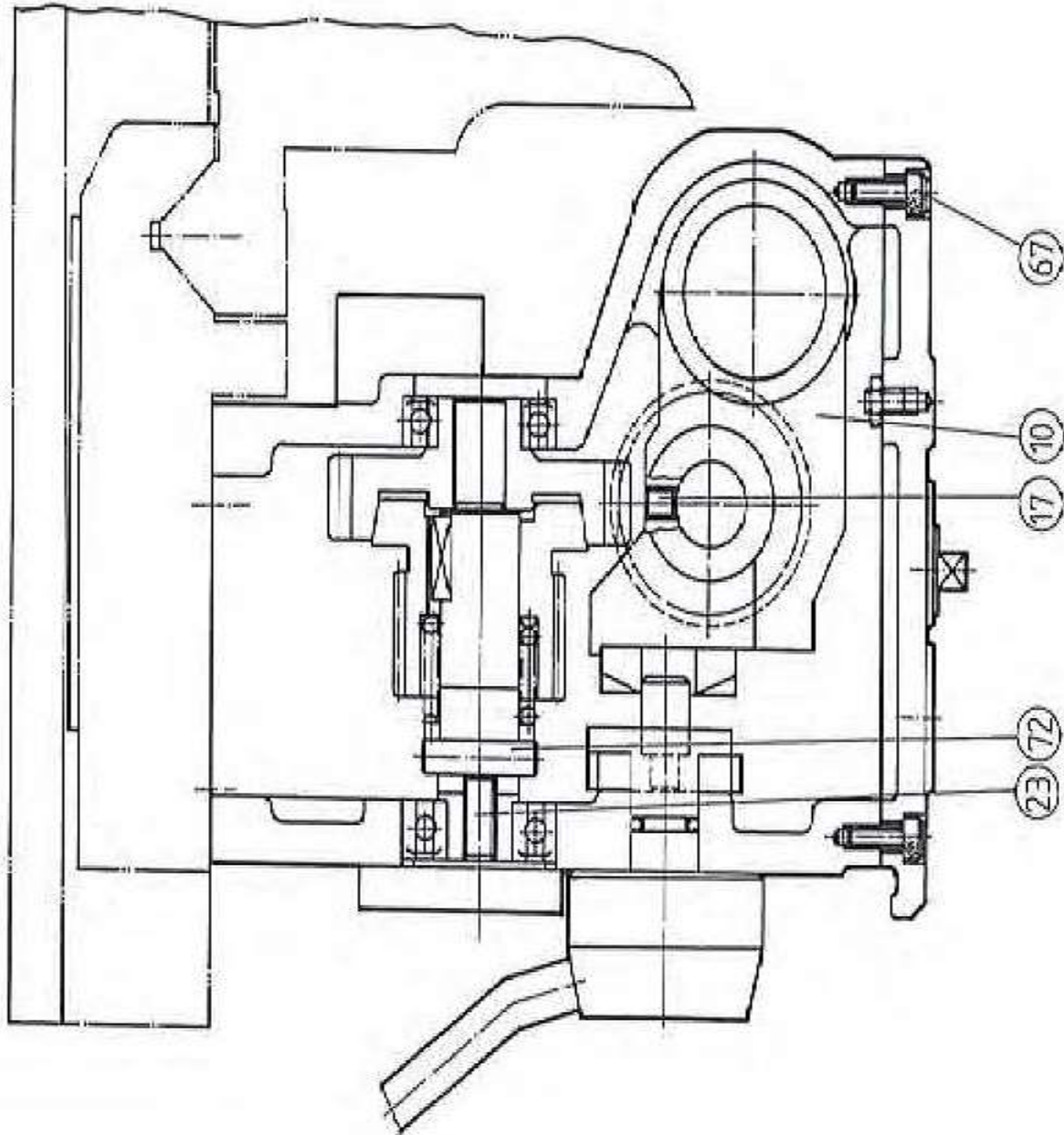

SECTION-Y-Y



APRON ASSEMBLY (LEFT HAND) 5/5

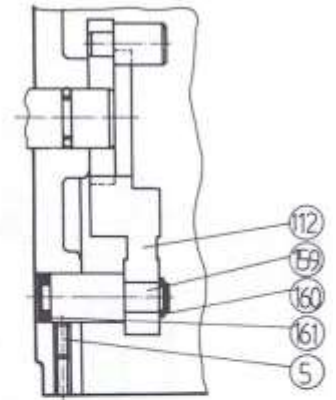

SECTION:R-R

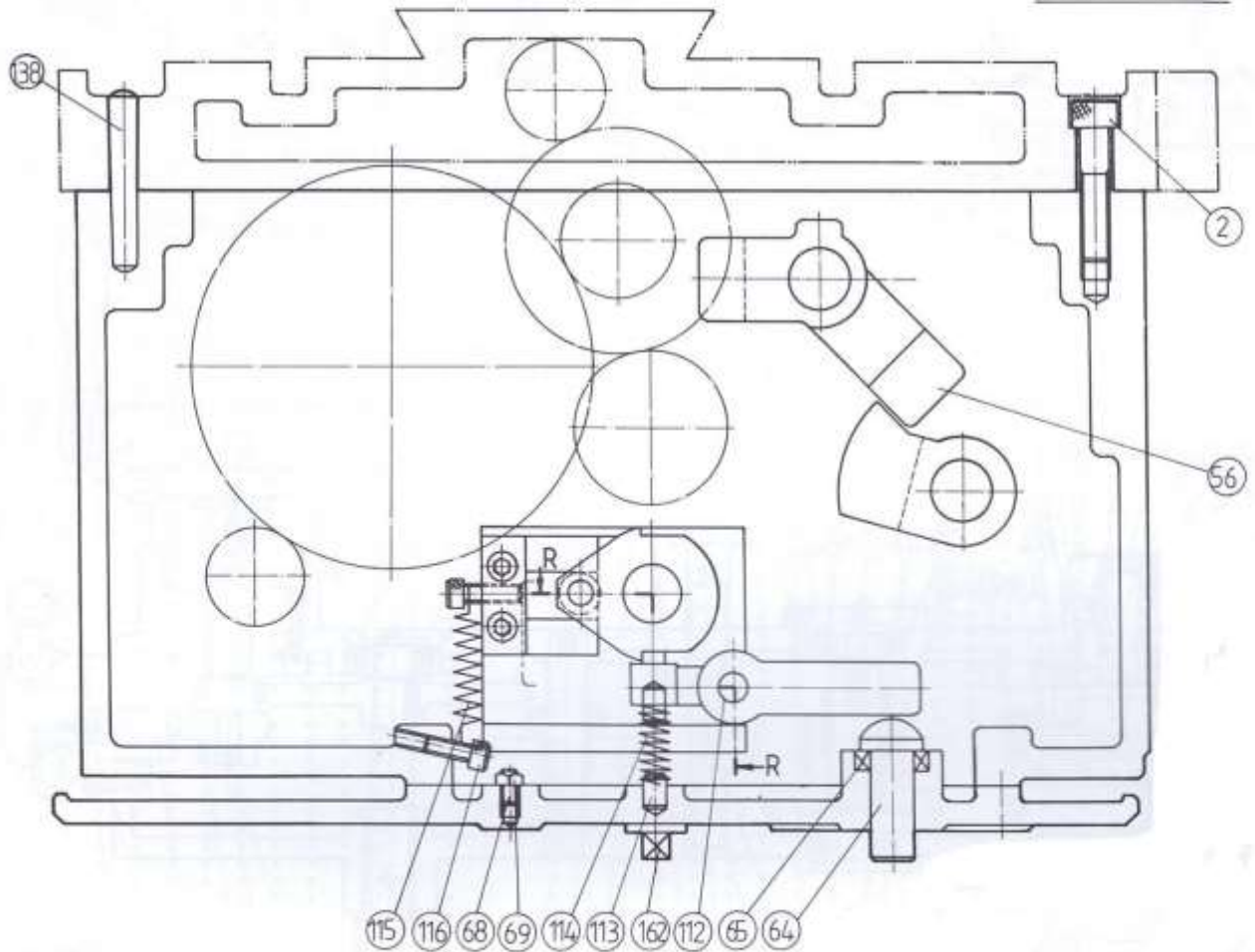

SECTION:L-L



APRON PARTS IDENTIFICATION

No.	Part No.	Name	Specification	Qty.
1	60-0401L-00	Apron	(Left Hand)	1
2	SW02M10X45	Socket Head Cap Screw	M10xP1.5x45L	4
5	SW14M6X12	Socket Head Set Screw	M6xP1.0x12L	1
6	60-0401L-00-1	Oil Sight Glass		1
7	OR02W1.9XD53.8	O-Ring	W1.9xd53.8	1
8	SW04M5X10	Cross Recessed Head Screw	M5xP0.8x10L	6
9	OSSC34X48X7	Oil Seal	SC 34x48x7	2
10	60-0402-00	Bracket		1
11	60-0403-00	Gear	M2x24T	1
12	60-0404-01	Sleeve		1
13	KY036X6X20	Double Round Head Key	6x6x20L	1
14	60-0405-00	Bushing		2
15	SW15M8X16	Socket Head Set Screw	M8xP1.25x16L	2
16	60-0406-00	Shaft		1
17	SW14M8X8	Socket Head Set Screw	M8xP1.25x8L	1
18	60-0407-00	Bushing		2
19	60-0408-00	Worm		1
20	RB51104	Thrust Bearing	#51104	2
21	60-0409-00	Shaft		1
22	KY036X6X20	Double Round Head Key	6x6x20L	1
23	SW14M10X20	Socket Head Set Screw	M10xP1.5x20L	1
24	RB6204	Deep Groove Ball Bearing	#6204	1
25	60-0410-00	Worm Gear	M3x28T	1
26	RB6005/Z	Deep Groove Ball Bearing	#6005Z	1
27	60-0411-00	Clutch Gear	M1.75x28T	1
28	60-0412-00	Bearing Cover		1
29	SW02M6X12	Socket Head Cap Screw	M6Xp1.0X12l	3
30	60-0413-00	Shaft		1
31	OC01Ø1/4"	Ball Cup	Ø1/4"	1
32	SW14M6X8	Socket Head Set Screw	M6xP1.0x8L	1
33	60-0414-00	Gear	M1.75xx22T,45T	1
34	60-0415-00	Pinion Shaft		1
35	KY036X6X20	Double Round Head Key	6x6x20L	1



No.	Part No.	Name	Specification	Qty.
36	50-0423-00	Bushing		1
37	RR01STW20	Retaining Ring (External)	STW#20	3
38	RB62043	Deep Groove Ball Bearing	#6204	1
39	SW14M6X8	Socket Head Set Screw	M6xP1.0x8L	1
40	60-0416-00	Gear	M1.75x80T	1
41	60-0417-00	Pinion Shaft		1
42	PN03Ø4X30	Spring Pin	Ø4x30L	1
43	KY036X6X25	Double Round Head Key	6x6x25L	1
44	17-0504-2	Socket Button Head Screw	M8xP1.25x20L	1
45	SW14M5X20L	Socket Head Set Screw	M5xP0.8x20L	1
46	60-0418-1/2-00	Dial	(Metric)	1
46	60-0418-2/2-00	Dial	(Imperial)	1
47	60-0419-00	Hand Wheel		1
48	60-0420-00	Feed Axis Selecting Shaft		1
49	SW14M6X6	Socket Head Set Screw	M6xP1.0x6L	1
50	PN03Ø5X30	Spring Pin	Ø5X30L	1
51	SB01Ø1/4"	Steel Ball	Ø1/4"	1
52	SG02Ø6XØ0.8X20	Compression Spring	Ø6XØ0.8X20L	1
53	SW14M8X8	Socket Head Set Screw	M8xP1.25x8L	1
54	SW15M8X12	Socket Head Set Screw	M8xP1.25x12L	1
55	SW14M8X10	Socket Head Set Screw	M8xP1.25x10L	1
56	60-0421-00	Shifting Fork		1
57	60-0422-00	Cam Shaft		1
58	60-0423-00	Half Nut Base		1
59	60-0424-1/2-00	Half Nut	(Metric)	1
59	60-0424-2/2-00	Half Nut	(Imperial)	1
60	SW01M8X16	Hex Head Screw	M8xP1.25x16L	2
61	WR03M8	Spring Washer		2
62	60-0425-00	Adjusting Screw		1
63	NT01M8	Hex Nut	M8xP1.25	1
64	60-0427-00	Acting Rod		1
65	OSTC15X25X7	Oil Seal	TC15x25x7	1
66	60-0428L-00	Bottom Cover		1
67	SW02M8X16	Socket Head Cap Screw	M6xP1.0x16L	8
68	SW14M6X12	Socket Head Set Screw	M6xP1.0x12L	1



No.	Part No.	Name	Specification	Qty.
69	NT01M6	Hex Nut	M6	1
70	50-0413-00	Compression Spring		1
71	50-0414-00	Spacer		1
72	50-0415-00	Pin		1
73	50-0420-01	Bushing		1
74	50-0422-00	Spacer		2
75	50-0425-00	Plug		1
76	50-0427-02	Bracket		1
77	50-0159-00	Bushing		2
78	OR01P34	O-Ring	P-34	1
79	SW02M6X20	Socket Head Cap Screw	M6xP1.0x20L	3
80	50-0431-00	Handle		1
81	50-0413-00	Washer		1
82	50-03111-00	Screw		1
83	50-0538-00	Pad Piece		1
84	50-0432-00	Cam		1
85	50-0439-00	Pin		2
86	50-0442-00	Safety Interlock Piece		1
87	PN03Ø5X35	Spring Pin	Ø5X35L	1
88	SW02M6X8	Socket Head Cap Screw	M6xP1.0x8L	1
89	50-0443-01	Parallel Gib		1
90	SW02M6X16	Socket Head Cap Screw	M6xP1.0x16L	3
91	SW14M6X22	Socket Head Set Screw	M6xP1.0x22L	4
92	NT02M6	Hex Nut	M6	4
93	50-0444-00	Lever Head		1
94	PN03Ø5X60	Spring Pin	Ø5X60L	1
95	SW14M6X20	Socket Head Set Screw	M6xP1.0x20L	1
96	SB01Ø1/4"	Steel Ball	Ø1/4"	1
97	SG02Ø6XØ0.8X20	Compression Spring	Ø6XØ0.8X20L	1
98	SW14M8X10	Socket Head Set Screw	M8xP1.25x10L	1
99	50-0445-00	Lever		1
100	50-01138-00	Knob		1
101	50-0446-00	Setting Block		1
102	SW02M6X12	Socket Head Cap Screw	M6xP1.0x12L	2
103	50-0448-00	Axle		1



No.	Part No.	Name	Specification	Qty.
104	OR01P16	O-Ring	P16xW2.4	1
105	KY036X6X20	Double Round Head Key	6x6x20L	1
106	50-0449-00	Swing Block		1
107	50-0450-00	Pin		1
108	50-0451-00	Lever Head		1
109	SW14M6X16	Socket Head Set Screw	M6xP1.0x16L	1
110	PN03Ø5X10	Spring Pin	Ø5X10L	1
111	PN03Ø4X20	Spring Pin	Ø4X20L	1
112	50-0457-00	Swing Arm		1
113	50-0458-00	Pin		2
114	50-0459-00	Compression Spring		1
115	50-0460-00	Extension Spring		1
116	SW02M6X16	Socket Head Cap Screw	M6xP1.0x16L	2
117	50-0462-00	Lube Pump Casting		1
118	SW02M6X16	Socket Head Cap Screw	M6xP1.0x16L	4
119	50-0463-00	Plunger		1
120	50-0464-00	Compression Spring		1
121	50-0465-00	Piston Rod		1
122	50-0466-00	Compression Spring		1
123	50-0467-00	Adjusting Nut		1
124	50-0468-00	Knob		1
125	PN03Ø2.5X15	Spring Pin	Ø2.5X15L	1
126	50-0469-00	Check Valve		1
127	OR01P16	O-Ring	P16xW2.4	1
128	50-0470-00	Collar		1
129	50-0471-00	Special Bolt		1
130	OR01P14	O-Ring	P14xW2.4	1
131	50-0472-00	Bushing		1
132	SB01Ø5/16	Steel Ball	Ø5/16	1
133	50-0473-00	Packing		1
134	50-0475-00	Feed Engagement Indicator		1
135	50-0478-00	Feed Axis Selecting Indicator		1
136	50-0168-00	Indicator		1
137	50-0181-00	Indicator		1
138	50-0484-00	Taper Pin w/Internal Thread	#7x57L	2



No.	Part No.	Name	Specification	Qty.
139	50-0485-01	Thread Dial Indicator		1
140	SW02M8X80	Socket Head Cap Screw	M8xP1.25x80L	1
141	RT01Ø2X5	Button Head Rivet	Ø2X5L	14
142	50-0486-01	Thread Dial Indicator		1
143	PN01Ø3X8	Pin	Ø3X8L	3
144	WR01M10	Washer	M10	1
145	NT02M10	Hex Nut	M10xP1.5	1
146	50-0488-01	Helical Gear (used for Metric)	MP2.0x14T	1
147	50-0489-01	Helical Gear (used for Metric)	MP2.0x15T	1
148	50-0490-01	Helical Gear (used for Metric)	MP2.0x16T	1
149	50-0491-01	Helical Gear (used for Metric)	MP2.0x22T	1
150	50-0495-01	Spacer		1
151	50-0496-01	Helical Gear (Used for Imperial)	MP2.0x16T	1
152	50-0497-01	Spacer (Used for Imperial)		1
153	50-0493-00	Indicator Table	(Metric)	1
153	50-0498-00	Indicator Table	(Imperial)	1
154	50-04122A-00	Indicator		1
155	10-0201-01-7	Input Oil Plug		1
156	50-04115-00	Lever		1
157	50-04116-00	Knob		1
158	50-04118-00	Lube Pump Indicator		1
159	50-04121-00	Shaft		1
160	RR01STW10	Retaining Ring (External)	STW#10	1
161	OR01P12	O-Ring	P12xW2.4	1
162	17-0274-00	Drain Plug		1
163	50-0499-01	Thread Dial Body		1
164	SW02M8X90	Socket Head Cap Screw	M8xP1.25x90L	1
165	WR01M8	Washer	M8	3
166	50-04101-00	Axle A	(Optional)	1
167	PN01Ø3X6	Pin	Ø3X6	1
168	NT01M8	Hex Nut	M8xP1.25	2
169	50-04103-01	Spur Gear (Optional)	M1.0x22T	1
170	50-04104-01	Spur Gear (Optional)	M1.0x24T	1
171	50-04105-01	Helical Gear	MP2x15T	1
172	50-04106-01	Helical Gear	MP2x16T	1



No.	Part No.	Name	Specification	Qty.
173	50-04107-01	Helical Gear	MP2x20T	1
174	50-04108-01	Helical Gear	MP2x25T	1
175	50-04109-01	Spacer	(Optional)	1
176	SW16M5X8	Socket Head Set Screw	M5xP0.8x8L	1
177	50-04110-01	B-Shaft	(Optional)	1
178	50-04111-01	Spur Gear (Optional)	M1.0x42T	1
179	50-04112-01	Spur Gear (Optional)	M1.0x44T	1
180	50-04113-01	Indicator Table	(Optional)	1
181	50-04122-00	Indicator		1
182	60-0430-00	Feed Axis Selecting Indicator		1
183	60-0431-00	Cone Clutch Adjusting Indicator		1



TAIL STOCK ASSEMBLY 1/2

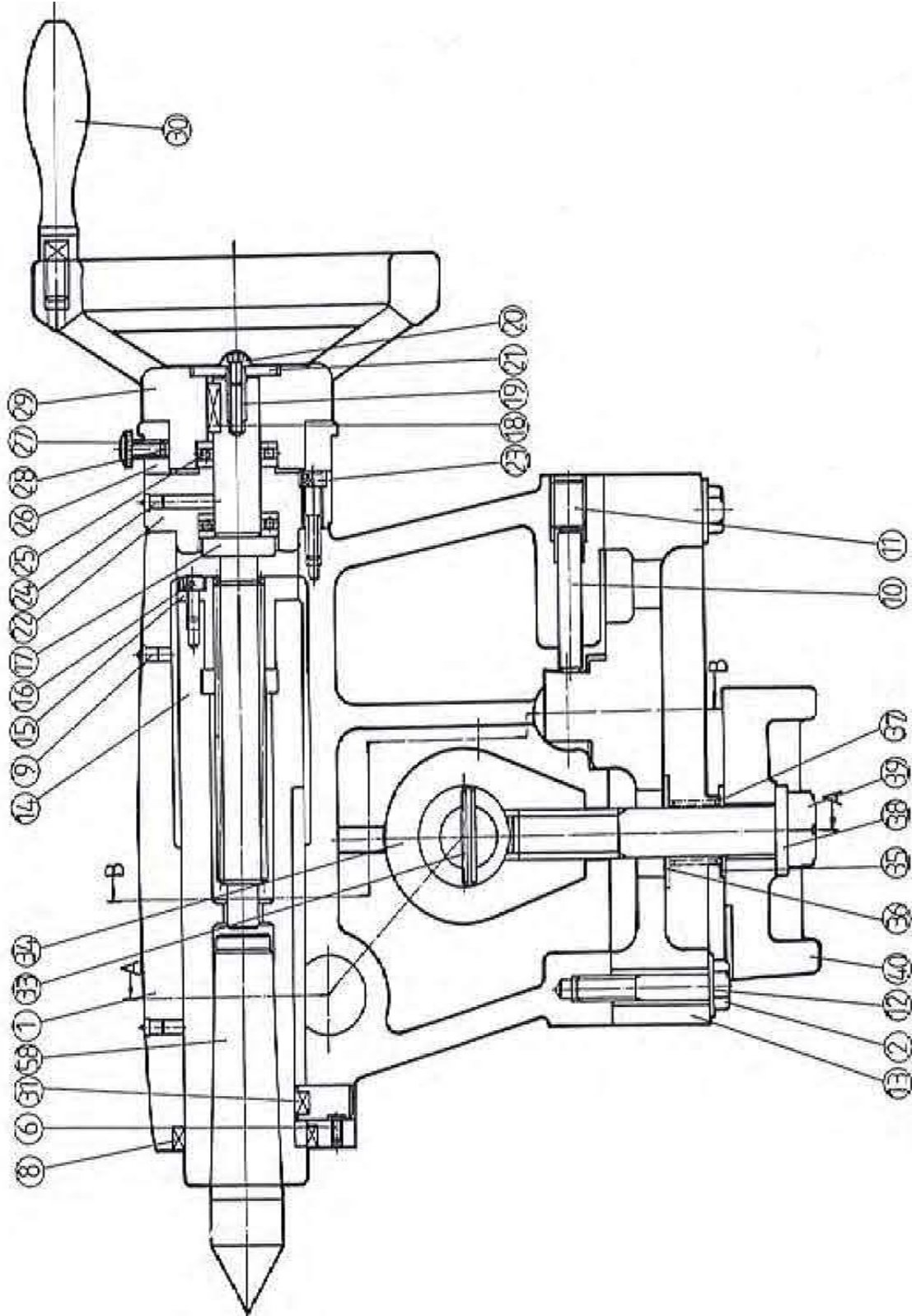



TAIL STOCK ASSEMBLY 2/2

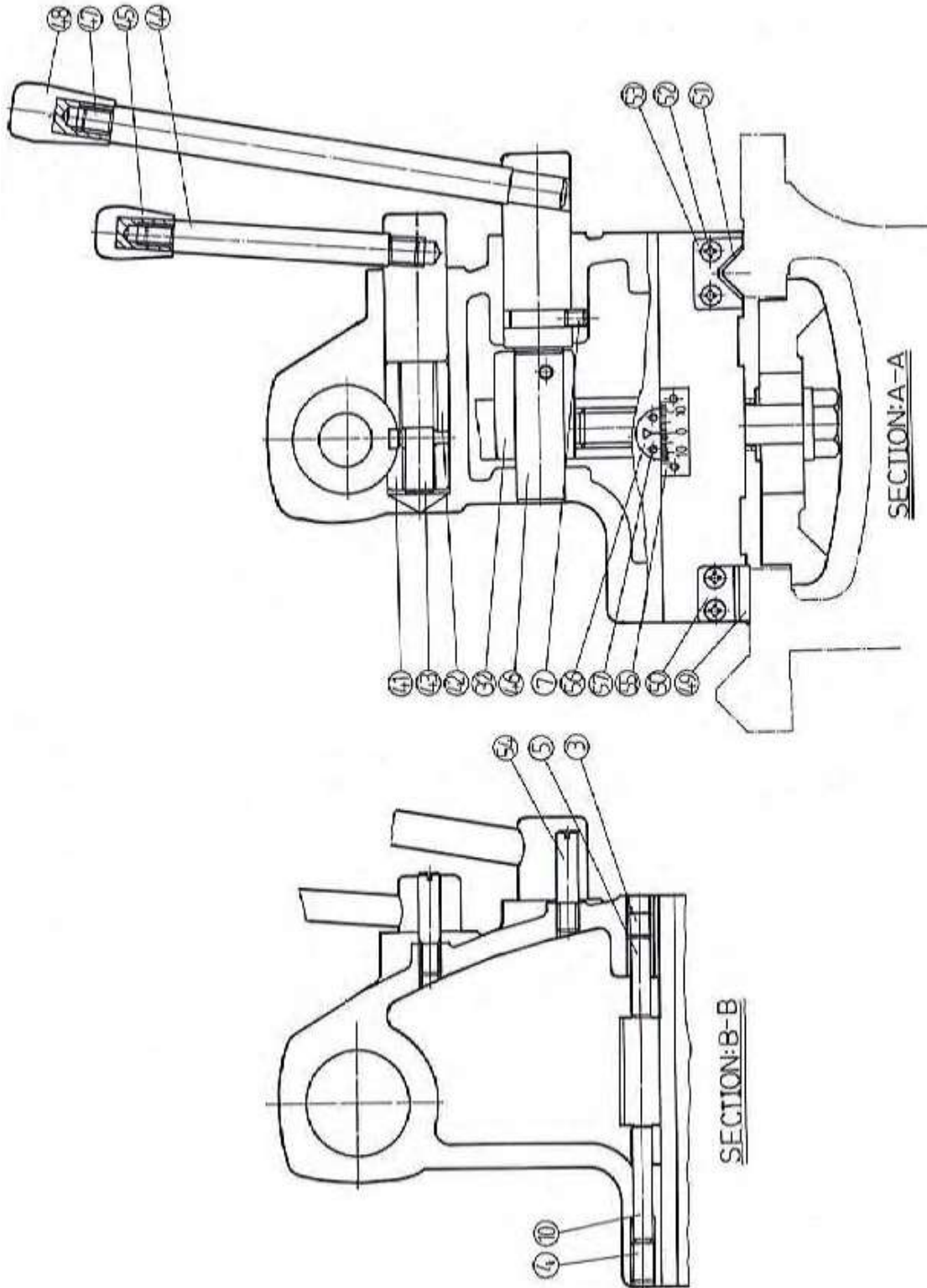



TAIL STOCK PARTS IDENTIFICATION

No.	Part No.	Name	Specification	Qty.
1	60-0501-00	Tail Stock Body		1
2	SW01M10X60	Hex Head Screw	M10xP1.5x60L	2
3	SW14M12X12	Socket Head Set Screw	M12xP1.75x12L	1
4	SW14M12X20	Socket Head Set Screw	M12xP1.75x20L	2
5	PN01Ø10X40	Parallel Pin	Ø10x40L	1
6	SW14M6X10	Socket Head Set Screw	M6xP1.0x10L	1
7	SW14M8X10	Socket Head Set Screw	M8xP1.25x10L	1
8	OSTC54X64X9	Oil Seal	TC Ø54xØ64x9	1
9	OC01Ø1/4"	Ball Cup	Ø1/4"	2
10	50-0535-00	Parallel Pin	Ø10x58L	2
11	SW14M12X20	Socket Head Set Screw	M12xP1.75x20L	1
12	23-0112-00	Washer	Ø10.5xØ25.4x2t	2
13	62-0502-00	Tail Stock Base		1
14	60-0503-00	Quill		1
15	60-0504-00	Feed Nut	(Metric)	1
15	60-0505-00	Feed Nut	(Imperial)	1
16	SW02M6X12	Socket Head Cap Screw	M6xP1.0x12L	4
17	60-0506-00	Feed Screw	(Metric)	1
17	60-0507-00	Feed Screw	(Imperial)	1
18	KY036X6X20	Double Round Head Key	6x6x20L	1
19	SW14M5X20	Socket Head Set Screw	M5xP0.8x20L	1
20	17-0504-00-2	Socket Button Head Screw	M8xP1.25x20L	1
21	50-0513-00	Washer		1
22	60-0508-00	Bracket		1
23	SW02M6X30	Socket Head Cap Screw	M6xP1.0x30L	4
24	OC01Ø1/4"	Ball Cup	Ø1/4"	1
25	RB51104	Thrust Bearing	#51104	2
26	50-0509-00	Dial	(Metric)	1
26	50-0510-00	Dial	(Imperial)	1
27	50-03111-00	Screw		1
28	50-0338-00	Bushing		1
29	60-0511-00	Hand Wheel		1
30	50-0431-00	Handle		1



No.	Part No.	Name	Specification	Qty.
31	50-0514-00	Guide Pin		1
32	50-0521-00	Eccentric Collar		1
33	PN03Ø6X40	Spring Pin	Ø6X40L	1
34	50-0522-00	Adjusting Block		1
35	50-0523-00	Washer		1
36	50-0524-00	Washer		1
37	50-0525-00	Compression Spring		1
38	50-0526-00	Washer		1
39	50-0527-00	Hex Head Screw		1
40	50-0528-00	Clamping Block		1
41	60-0515-00	Locking Nut		1
42	60-0516-00	Locking Sleeve		1
43	50-0517-00	Locking Rod		1
44	50-0518-00	Lever		1
45	50-01138-00	Knob		1
46	50-0519-00	Shaft		1
47	50-0520-00	Lever		1
48	50-0166-00	Knob		1
49	50-0530-00	Bed Way Wiper		2
50	50-0531-00	Bed Way Wiper Plate		2
51	50-0532-00	Bed Way Wiper		2
52	SW04M6X15	Cross Recessed Head Screw	M6xP1.0x15L	8
53	50-0533-00	Bed Way Wiper Plate		2
54	50-0534-00	Stud		2
55	50-0536-00	Set-Over Indicating Plate		1
56	50-0537-00	Indicator		1
57	RT01Ø2X5	Button Head Rivet	Ø2X5	4
58	14-0129	Center	MT#4	1



BED ASSEMBLY 1/2

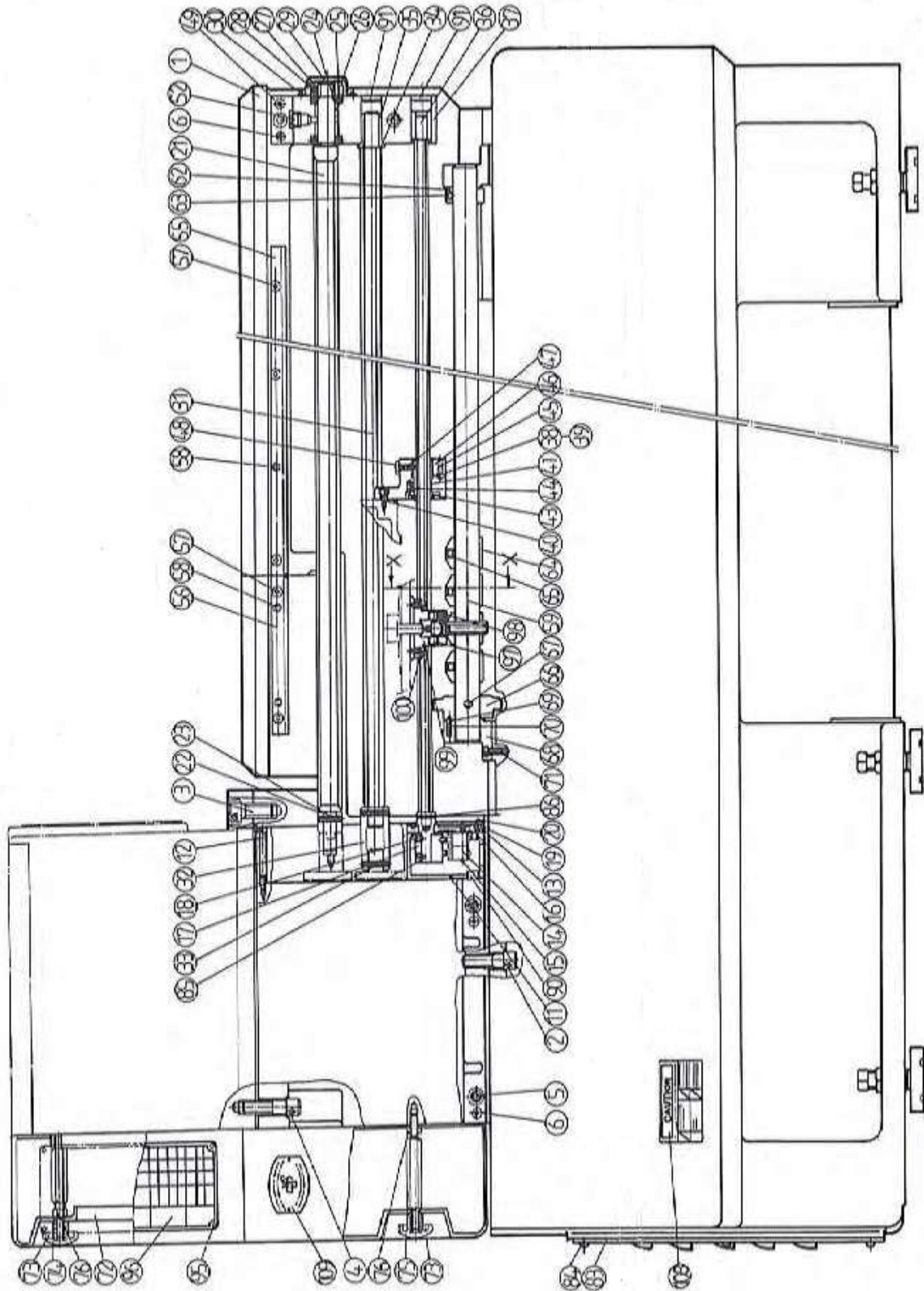



BED ASSEMBLY 2/2

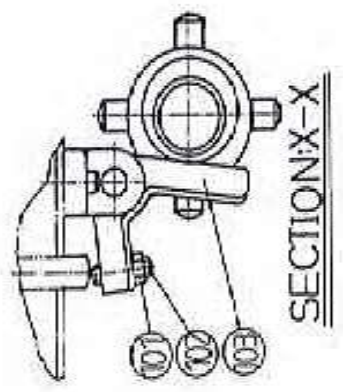
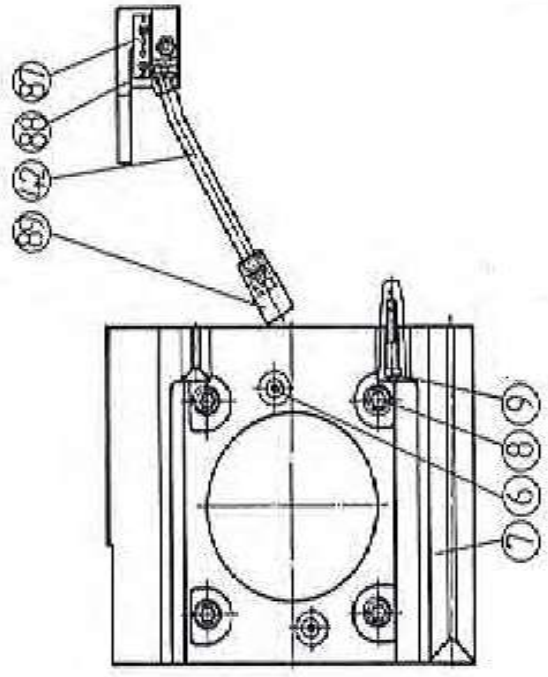
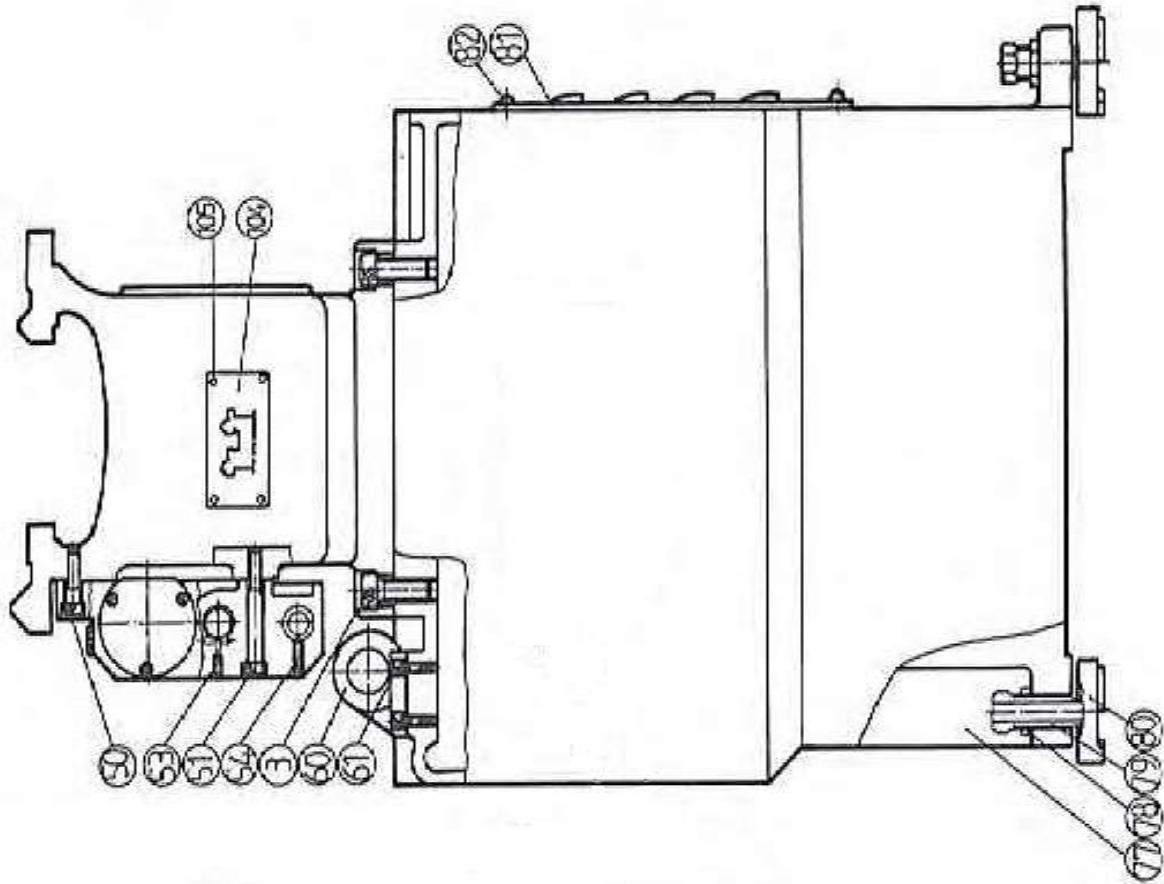



BED PARTS IDENTIFICATION

No.	Part No.	Name	Specification	Qty.
1	60-0601C-00	Bed Gap Type)		1
1	60-0601D-00	Bed (Straight Type)		1
2	SW02M16X55	Socket Head Cap Screw	M16xP2.0x55L	6
3	SW02M16X45	Socket Head Cap Screw	M16xP2.0x45L	6
4	SW02M16X60	Socket Head Cap Screw	M16xP2.0x60L	3
5	SW02M10X40	Socket Head Cap Screw	M10xP1.5x40L	4
6	50-0484-00	Taper Pin w/Internal Thread	#7x57L	6
7	60-0602-00	Gap Block		1
8	SW02M12X60	Socket Head Cap Screw	M12xP1.75x60L	4
9	SW02M8X45	Socket Head Cap Screw	M8xP1.25x45L	2
11	62-0626-00	Switch Box	TY-18TS	1
12	SW02M6X75	Socket Head Cap Screw	M6xP1.0x75L	3
13	60-0628-00	Switch Cover		1
14	LSTM1704	Micro Switch	TM1704,Z-15G,22-B	2
15	SW04M4X40	Cross Recessed Head Screw	M4xP0.7x40L	2
16	SW02M5X12	Socket Head Cap Screw	M5xP0.8x12L	3
17	17-0697-00	Cam		1
18	SW15M5X8	Socket Head Set Screw	M5xP0.8x8L	2
19	60-0630-00	Side Plate		1
20	SW04M5X8	Cross Recessed Head Screw	M5xP0.8x8L	4
21	62-0637B-00	Lead Screw	(Metric)	1
21	62-0638B-00	Lead Screw	(Imperial)	1
22	60-0641-00	Coupling		1
23	PN07Ø4X32	Copper Pin	Ø4X32L	1
24	50-0642-00	Bushing		2
25	RB51105	Thrust Bearing	#51105	2
26	50-0643-00	Locking Nut		1
27	50-0643-00-1	Copper Pad	Ø6.5x2L	1
28	SW14M8X8	Socket Head Set Screw	M8xP1.25x8L	1
29	50-0644-00	Dust Cover		1
30	SW04M5X8	Cross Recessed Head Screw	M5xP0.8x8L	3
31	62-0645B-01	Feed Rod		1



No.	Part No.	Name	Specification	Qty.
32	62-0250-00	Coupling		1
33	PN03Ø6X38	Spring Pin	Ø6x38L	2
34	50-0647-00	Spacer		1
35	50-0648-00	Bushing		1
36	62-0649B-00	Starting Rod		1
37	50-06144-00	Bushing		1
38	50-0651-00	Bracket		1
39	50-0652-00	Bracket		1
40	SW02M6X16	Socket Head Cap Screw	M6xP1.0x16L	1
41	50-0653-00	Sleeve		1
42	50-0654-00	Spindle Control Lever		1
43	17-0632-00	Thrust Piece		1
44	SG02Ø7.3Ø1.0X20	Compression Spring	Ø7.3xØ1.0x20L	3
45	17-0634-00	Position Setting Pin		1
46	17-0633-00	Gated Block		1
47	SW15M8X30	Socket Head Set Screw	M8xP1.25x30L	1
48	NT01M8	Hex Nut	M8xP1.25	1
49	60-0655-00	Bracket		1
50	SW02M10X40	Socket Head Cap Screw	M10xP1.5x40L	1
51	SW02M10X85	Socket Head Cap Screw	M10xP1.5x85L	1
52	10-0289-00	Input Oil Cap		1
53	SW14M6X12	Socket Head Set Screw	M6xP1.0x12L	1
54	SW14M6X20	Socket Head Set Screw	M6xP1.0x20L	1
55	60-0659A-00	Rack		1
56	60-0659-00	Rack (Gap Bed)		1
57	SW02M6X25	Socket Head Cap Screw	M6xP1.0x25L	6
58	PN03Ø6X36	Spring Pin	Ø6x36L	6
59	60-0661A-00	Feed Stop Rod		1
60	60-0663R-00	Feed Stop Bracket	(Right)	1
61	SW02M8X20	Socket Head Cap Screw	M8xP1.25x20L	2
62	50-06153-00	Collar		1
63	SW14M8X12	Socket Head Set Screw	M8xP1.25x12L	1
64	50-06156-00	Cam		4
65	SW14M8X10	Socket Head Set Screw	M8xP1.25x10L	4
66	50-06156-01	Selection Wheel		1



No.	Part No.	Name	Specification	Qty.
67	PN03Ø6X60	Spring Pin	Ø6x60L	1
68	60-0663L-00	Feed Stop Bracket	(Left)	1
69	SB01Ø1/4"	Steel Ball	Ø1/4"	1
70	SG02Ø6.5XØ1.0X25	Compression Spring	Ø6.5xØ1.0x25L	1
71	SW02M8X20	Socket Head Cap Screw	M8xP1.25x20L	2
72	61-0657-00	End Cover		1
73	50-0660A-00	Clamping Knob		2
74	60-0632-00	Positioning		1
75	60-0634-00	Positioning		1
76	NT01M10	Hex Nut	M10xP1.5	2
77	60-0674A-00	Base		1
78	50-06120-00	Locking Nut		6
79	50-06121-00	Adjusting Bolt		6
80	50-06122-00	Leveling Block		6
81	50-06115-00	Rear Cover	R.H. Base	1
82	SW04M6X8	Cross Recessed Head Screw	M6xP1.0x8L	4
83	50-06114-00	Rear Cover	L.H. Base	1
84	SW04M6X8	Cross Recessed Head Screw	M6xP1.0x8L	4
85	50-06119-00	Cam Axle		1
86	PN03Ø3X24	Spring Pin	Ø3x24L	1
87	17-0678-00	Spindle direction Indicator		1
88	RT01Ø2X5	Button Head Rivet	Ø2x5L	2
89	50-0166-00	Knob	M12	1
90	11-0767-00	Electric Wire Protective Bushing		2
91	50-06123-00	Plug		2
93	60-0660-00	Model Name Plate		1
96	60-0254-00	Thread Cutting Table	(Metric)	1
96	60-0255-00	Thread Cutting Table	(Imperial)	1
97	50-06158-00	Pin		1
98	SW14M6X10	Socket Head Set Screw	M6xP1.0x10L	1
99	50-06157-00	Bracket		1
100	SW02MX25	Socket Head Cap Screw	M8xP1.25x25L	2
101	NT01M8	Hex Nut	M8	1
102	SW14M8X35	Socket Head Cap Screw	M8xP1.25x35L	1
103	50-06159-00	Rocking Arm		1



No.	Part No.	Name	Specification	Qty.
104	11-0625	Bed Way Surface Indicator		1
105	RT01Ø2X5	Button Head Rivet	Ø2x5L	4
108	50-06162-00	Caution Indicator		1
109	11-0628A-02	CNS Certification Indicator		1



NOTES



NOTES



BAILEIGH INDUSTRIAL, INC. 1625 DUFEK DRIVE MANITOWOC, WI 54220

PHONE: 920. 684. 4990 FAX: 920. 684. 3944

www.baileigh.com

BAILEIGH INDUSTRIAL, INC. 1455 S. CAMPUS AVENUE ONTARIO, CA 91761

PHONE: 920. 684. 4990 FAX: 920. 684. 3944

BAILEIGH INDUSTRIAL LTD. UNIT 1 FULLWOOD CLOSE

ALDERMANS GREEN INDUSTRIAL ESTATE

COVENTRY, CV2 2SS UNITED KINGDOM

PHONE: +44 (0)24 7661 9267 FAX: +44 (0)24 7661 9276

WWW.BAILEIGHINDUSTRIAL.CO.UK

BAILEIGH INDUSTRIAL GMBH HOFENER STRAÙE 64

70736 FELLBACH

DEUTCHSLAND

WWW.BAILEIGHINDUSTRIAL.DE