



# OPERATOR'S MANUAL

**Metal Working**



## 75 TON SHOP PRESS MODEL: HSP-75A

Baileigh Industrial, Inc.  
P.O. Box 531  
Manitowoc, WI 54221-0531  
Phone: 920.684.4990  
Fax: 920.684.3944  
[sales@baileigh.com](mailto:sales@baileigh.com)

REPRODUCTION OF THIS MANUAL IN ANY FORM WITHOUT WRITTEN APPROVAL OF BAILEIGH INDUSTRIAL, INC. IS PROHIBITED. Baileigh Industrial, Inc. does not assume and hereby disclaims any liability for any damage or loss caused by an omission or error in this Operator's Manual, resulting from accident, negligence, or other occurrence.

Rev. 03/2017

© 2017 Baileigh Industrial, Inc.



## Table of Contents

THANK YOU & WARRANTY .....	1
INTRODUCTION.....	3
GENERAL NOTES.....	3
SAFETY INSTRUCTIONS .....	4
SAFETY PRECAUTIONS .....	6
Dear Valued Customer:.....	6
MACHINE SAFETY LABELS .....	8
TECHNICAL SPECIFICATIONS.....	9
TECHNICAL SUPPORT .....	9
UNPACKING AND CHECKING CONTENTS.....	10
Cleaning .....	10
TRANSPORTING AND LIFTING .....	11
INSTALLATION.....	12
Anchoring the Machine.....	13
DIMENSIONS .....	14
GETTING TO KNOW YOUR MACHINE .....	15
ASSEMBLY.....	16
SETUP AND ADJUSTMENTS .....	19
Ram Slide Adjustment .....	19
Purging the System .....	20
OPERATION PREPLANNING .....	21
OPERATION.....	23
Moving the Bed Frame .....	23
Sequence of Operation.....	24
UNDERSTANDING SPRINGBACK .....	25
MATERIAL SELECTION.....	25
LUBRICATION AND MAINTENANCE .....	26
PARTS DIAGRAM .....	28
Parts List .....	31
MAIN CYLINDER ASSEMBLY PARTS DIAGRAM .....	34
Main Cylinder Assembly Parts List .....	35
PUMP ASSEMBLY PARTS DIAGRAM.....	36
Pump Assembly Parts List.....	37
HYDRAULIC SCHEMATIC .....	39
TROUBLESHOOTING .....	40



## THANK YOU & WARRANTY

Thank you for your purchase of a machine from Baileigh Industrial. We hope that you find it productive and useful to you for a long time to come.

**Inspection & Acceptance.** Buyer shall inspect all Goods within ten (10) days after receipt thereof. Buyer's payment shall constitute final acceptance of the Goods and shall act as a waiver of the Buyer's rights to inspect or reject the goods unless otherwise agreed. If Buyer rejects any merchandise, Buyer must first obtain a Returned Goods Authorization ("RGA") number before returning any goods to Seller. Goods returned without a RGA will be refused. Seller will not be responsible for any freight costs, damages to goods, or any other costs or liabilities pertaining to goods returned without a RGA. Seller shall have the right to substitute a conforming tender. Buyer will be responsible for all freight costs to and from Buyer and repackaging costs, if any, if Buyer refuses to accept shipment. If Goods are returned in unsalable condition, Buyer shall be responsible for full value of the Goods. Buyer may not return any special-order Goods. Any Goods returned hereunder shall be subject to a restocking fee equal to 30% of the invoice price.

**Specifications.** Seller may, at its option, make changes in the designs, specifications or components of the Goods to improve the safety of such Goods, or if in Seller's judgment, such changes will be beneficial to their operation or use. Buyer may not make any changes in the specifications for the Goods unless Seller approves of such changes in writing, in which event Seller may impose additional charges to implement such changes.

**Limited Warranty.** Seller warrants to the original end-user that the Goods manufactured or provided by Seller under this Agreement shall be free of defects in material or workmanship for a period of twelve (12) months from the date of purchase, provided that the Goods are installed, used, and maintained in accordance with any instruction manual or technical guidelines provided by the Seller or supplied with the Goods, if applicable. The original end-user must give written notice to Seller of any suspected defect in the Goods prior to the expiration of the warranty period. The original end-user must also obtain a RGA from Seller prior to returning any Goods to Seller for warranty service under this paragraph. Seller will not accept any responsibility for Goods returned without a RGA. The original end-user shall be responsible for all costs and expenses associated with returning the Goods to Seller for warranty service. In the event of a defect, Seller, at its sole option, shall repair or replace the defective Goods or refund to the original end-user the purchase price for such defective Goods. Goods are not eligible for replacement or return after a period of 30 days from date of receipt. The foregoing warranty is Seller's sole obligation, and the original end-user's exclusive remedy, with regard to any defective Goods. This limited warranty does not apply to: (a) die sets, tooling, and saw blades; (b) periodic or routine maintenance and setup, (c) repair or replacement of the Goods due to normal wear and tear, (d) defects or damage to the Goods resulting from misuse, abuse, neglect, or accidents, (e) defects or damage to the Goods resulting from improper or unauthorized alterations, modifications, or changes; and (f) any Goods that has not been installed and/or maintained in accordance with the instruction manual or technical guidelines provided by Seller.

**EXCLUSION OF OTHER WARRANTIES.** THE FOREGOING LIMITED WARRANTY IS IN LIEU OF ALL OTHER WARRANTIES, EXPRESS OR IMPLIED. ANY AND ALL OTHER EXPRESS, STATUTORY OR IMPLIED WARRANTIES, INCLUDING BUT NOT LIMITED TO, ANY WARRANTY OF MERCHANTABILITY OR FITNESS FOR ANY PARTICULAR PURPOSE ARE EXPRESSLY DISCLAIMED. NO WARRANTY IS MADE WHICH EXTENDS BEYOND THAT WHICH IS EXPRESSLY CONTAINED HEREIN.

**Limitation of Liability.** IN NO EVENT SHALL SELLER BE LIABLE TO BUYER OR ANY OTHER PARTY FOR ANY INCIDENTAL, CONSEQUENTIAL OR SPECIAL DAMAGES (INCLUDING, WITHOUT LIMITATION, LOST PROFITS OR DOWN TIME) ARISING FROM OR IN MANNER CONNECTED WITH THE GOODS, ANY BREACH BY SELLER OR ITS AGENTS OF THIS AGREEMENT, OR ANY OTHER CAUSE WHATSOEVER, WHETHER BASED ON CONTRACT, TORT OR ANY OTHER THEORY OF LIABILITY. BUYER'S REMEDY WITH RESPECT TO ANY CLAIM ARISING UNDER THIS AGREEMENT IS STRICTLY LIMITED TO NO MORE THAN THE AMOUNT PAID BY THE BUYER FOR THE GOODS.



**Force Majeure.** Seller shall not be responsible for any delay in the delivery of, or failure to deliver, Goods due to causes beyond Seller's reasonable control including, without limitation, acts of God, acts of war or terrorism, enemy actions, hostilities, strikes, labor difficulties, embargoes, non-delivery or late delivery of materials, parts and equipment or transportation delays not caused by the fault of Seller, delays caused by civil authorities, governmental regulations or orders, fire, lightening, natural disasters or any other cause beyond Seller's reasonable control. In the event of any such delay, performance will be postponed by such length of time as may be reasonably necessary to compensate for the delay.

**Installation.** If Buyer purchases any Goods that require installation, Buyer shall, at its expense, make all arrangements and connections necessary to install and operate the Goods. Buyer shall install the Goods in accordance with any Seller instructions and shall indemnify Seller against any and all damages, demands, suits, causes of action, claims and expenses (including actual attorneys' fees and costs) arising directly or indirectly out of Buyer's failure to properly install the Goods.

**Work By Others; Safety Devices.** Unless agreed to in writing by Seller, Seller has no responsibility for labor or work performed by Buyer or others, of any nature, relating to design, manufacture, fabrication, use, installation or provision of Goods. Buyer is solely responsible for furnishing, and requiring its employees and customers to use all safety devices, guards and safe operating procedures required by law and/or as set forth in manuals and instruction sheets furnished by Seller. Buyer is responsible for consulting all operator's manuals, ANSI or comparable safety standards, OSHA regulations and other sources of safety standards and regulations applicable to the use and operation of the Goods.

**Remedies.** Each of the rights and remedies of Seller under this Agreement is cumulative and in addition to any other or further remedies provided under this Agreement or at law or equity.

**Attorney's Fees.** In the event legal action is necessary to recover monies due from Buyer or to enforce any provision of this Agreement, Buyer shall be liable to Seller for all costs and expenses associated therewith, including Seller's actual attorneys' fees and costs.

**Governing Law/Venue.** This Agreement shall be construed and governed under the laws of the State of Wisconsin, without application of conflict of law principles. Each party agrees that all actions or proceedings arising out of or in connection with this Agreement shall be commenced, tried, and litigated only in the state courts sitting in Manitowoc County, Wisconsin or the U.S. Federal Court for the Eastern District of Wisconsin. Each party waives any right it may have to assert the doctrine of "forum non conveniens" or to object to venue to the extent that any proceeding is brought in accordance with this section. Each party consents to and waives any objection to the exercise of personal jurisdiction over it by courts described in this section. Each party waives to the fullest extent permitted by applicable law the right to a trial by jury.

**Summary of Return Policy.**

- 10 Day acceptance period from date of delivery. Damage claims and order discrepancies will not be accepted after this time.
- You must obtain a Baileigh issued RGA number PRIOR to returning any materials.
- Returned materials must be received at Baileigh in new condition and in original packaging.
- Altered items are not eligible for return.
- Buyer is responsible for all shipping charges.
- A 30% re-stocking fee applies to all returns.

Baileigh Industrial makes every effort to ensure that our posted specifications, images, pricing and product availability are as correct and timely as possible. We apologize for any discrepancies that may occur. Baileigh Industrial reserves the right to make any and all changes deemed necessary in the course of business including but not limited to pricing, product specifications, quantities, and product availability.

**For Customer Service & Technical Support:**

Please contact one of our knowledgeable Sales and Service team members at:  
(920) 684-4990 or e-mail us at [sales@baileigh.com](mailto:sales@baileigh.com)



## **INTRODUCTION**

*The quality and reliability of the components assembled on a Baileigh Industrial machine guarantee near perfect functioning, free from problems, even under the most demanding working conditions. However if a situation arises, refer to the manual first. If a solution cannot be found, contact the distributor where you purchased our product. Make sure you have the serial number and production year of the machine (stamped on the nameplate). For replacement parts refer to the assembly numbers on the parts list drawings.*

*Our technical staff will do their best to help you get your machine back in working order.*

### **In this manual you will find: (when applicable)**

- Safety procedures
- Correct installation guidelines
- Description of the functional parts of the machine
- Capacity charts
- Set-up and start-up instructions
- Machine operation
- Scheduled maintenance
- Parts lists

## **GENERAL NOTES**

After receiving your equipment remove the protective container. Do a complete visual inspection, and if damage is noted, **photograph it for insurance claims** and contact your carrier at once, requesting inspection. Also contact Baileigh Industrial and inform them of the unexpected occurrence. Temporarily suspend installation.

Take necessary precautions while loading / unloading or moving the machine to avoid any injuries.

Your machine is designed and manufactured to work smoothly and efficiently. Following proper maintenance instructions will help ensure this. Try and use original spare parts, whenever possible, and most importantly; **DO NOT** overload the machine or make any modifications.



**Note:** This symbol refers to useful information throughout the manual.



## **IMPORTANT** **PLEASE READ THIS OPERATORS MANUAL CAREFULLY**

It contains important safety information, instructions, and necessary operating procedures. The continual observance of these procedures will help increase your production and extend the life of the equipment.

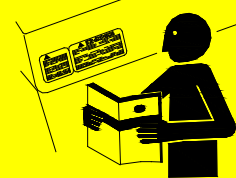

## **SAFETY INSTRUCTIONS**

### **LEARN TO RECOGNIZE SAFETY INFORMATION**

This is the safety alert symbol. When you see this symbol on your machine or in this manual, **BE ALERT TO THE POTENTIAL FOR PERSONAL INJURY!**

Follow recommended precautions and safe operating practices.

### **UNDERSTAND SIGNAL WORDS**

A signal word – **DANGER**, **WARNING**, or **CAUTION** is used with the safety alert symbol. **DANGER** identifies a hazard or unsafe practice that will result in severe **Injury or Death.**

Safety signs with signal word **DANGER** or **WARNING** are typically near specific hazards.

General precautions are listed on **CAUTION** safety signs. **CAUTION** also calls attention to safety messages in this manual.



**DANGER**



**WARNING**



**CAUTION**



**SAVE THESE INSTRUCTIONS.**  
**Refer to them often and use them to instruct others.**



**PROTECT EYES**

Wear safety glasses or suitable eye protection when working on or around machinery.

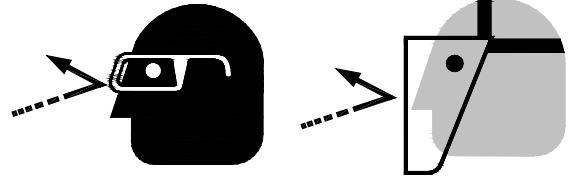

**PROTECT AGAINST NOISE**

Prolonged exposure to loud noise can cause impairment or loss of hearing. Wear suitable hearing protective devices such as ear muffs or earplugs to protect against objectionable or uncomfortable loud noises.

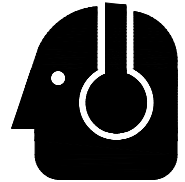

**HYDRAULIC HOSE FAILURE**

Exercise **CAUTION** around hydraulic hoses in case of a hose or fitting failure.

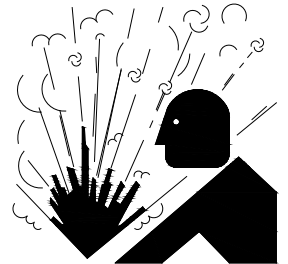

**BEWARE OF CRUSH HAZARD**

**NEVER** place your hands, fingers, or any part of your body in the die area of this machine. Keep hands and fingers away from the ram and tooling when the machine is in operation.

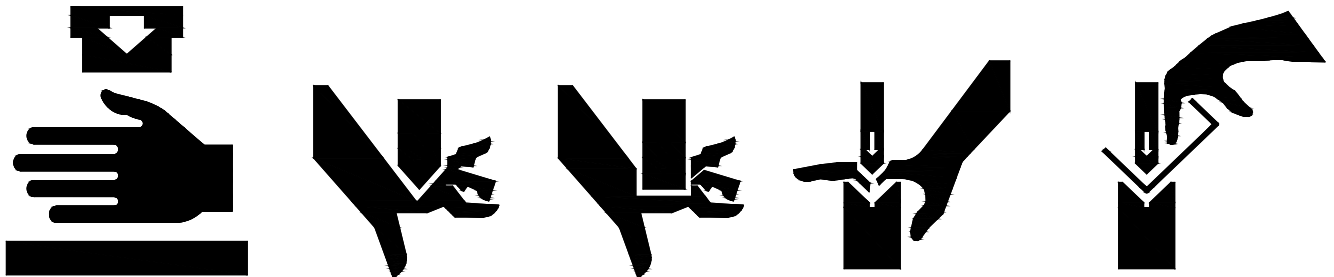



## SAFETY PRECAUTIONS



Metal working can be dangerous if safe and proper operating procedures are not followed. As with all machinery, there are certain hazards involved with the operation of the product. Using the machine with respect and caution will considerably lessen the possibility of personal injury. However, if normal safety precautions are overlooked or ignored, personal injury to the operator may result.

Safety equipment such as guards, hold-downs, safety glasses, dust masks and hearing protection can reduce your potential for injury. But even the best guard won't make up for poor judgment, carelessness or inattention. **Always use common sense** and exercise **caution** in the workshop. If a procedure feels dangerous, don't try it.

**REMEMBER: Your personal safety is your responsibility.**



**WARNING: FAILURE TO FOLLOW THESE RULES MAY RESULT IN SERIOUS PERSONAL INJURY**

Dear Valued Customer:

- All Baileigh machines should be used only for their intended use.
- Baileigh does not recommend or endorse making any modifications or alterations to a Baileigh machine. Modifications or alterations to a machine may pose a substantial risk of injury to the operator or others and may do substantial damage to the machine.
- Any modifications or alterations to a Baileigh machine will invalidate the machine's warranty.

**PLEASE ENJOY YOUR BAILEIGH MACHINE! ....PLEASE ENJOY IT SAFELY!**

1. **FOR YOUR OWN SAFETY, READ INSTRUCTION MANUAL BEFORE OPERATING THE MACHINE.** Learn the machine's application and limitations as well as the specific hazards.
2. **Only trained and qualified personnel can operate this machine.**
3. **Make sure guards are in place and in proper working order before operating machinery.**
4. **Remove any adjusting tools.** Before operating the machine, make sure any adjusting tools have been removed.
5. **Keep work area clean.** Cluttered areas invite injuries.
6. **Overloading machine.** By overloading the machine you may cause injury from flying parts. **DO NOT** exceed the specified machine capacities.



7. **Dressing material edges.** Always chamfer and deburr all sharp edges.
8. **Do not force tool.** Your machine will do a better and safer job if used as intended. **DO NOT** use inappropriate attachments in an attempt to exceed the machines rated capacity.
9. **Use the right tool for the job. DO NOT** attempt to force a small tool or attachment to do the work of a large industrial tool. **DO NOT** use a tool for a purpose for which it was not intended.
10. **Dress appropriate. DO NOT** wear loose fitting clothing or jewelry as they can be caught in moving machine parts. Protective clothing and steel toe shoes are recommended when using machinery. Wear a restrictive hair covering to contain long hair.
11. **Use eye and ear protection.** Always wear ISO approved impact safety goggles. Wear a full-face shield if you are producing metal filings.
12. **Do not overreach.** Maintain proper footing and balance at all times. **DO NOT** reach over or across a running machine.
13. **Stay alert.** Watch what you are doing and use common sense. **DO NOT** operate any tool or machine when you are tired.
14. **Check for damaged parts.** Before using any tool or machine, carefully check any part that appears damaged. Check for alignment and binding of moving parts that may affect proper machine operation.
15. **Observe work area conditions. DO NOT** use machines or power tools in damp or wet locations. Do not expose to rain. Keep work area well lighted.
16. **Keep children away.** Children must never be allowed in the work area. **DO NOT** let them handle machines, tools, or extension cords.
17. **Store idle equipment.** When not in use, tools must be stored in a dry location to inhibit rust. Always lock up tools and keep them out of reach of children.
18. **DO NOT operate machine if under the influence of alcohol or drugs.** Read warning labels on prescriptions. If there is any doubt, **DO NOT** operate the machine.
19. Keep visitors a safe distance from the work area.

 **CAUTION:** Never connect to an air source capable of exceeding 120 PSI. Over pressurizing the tool may cause bursting, breakage, or serious personal injury.



## MACHINE SAFETY LABELS

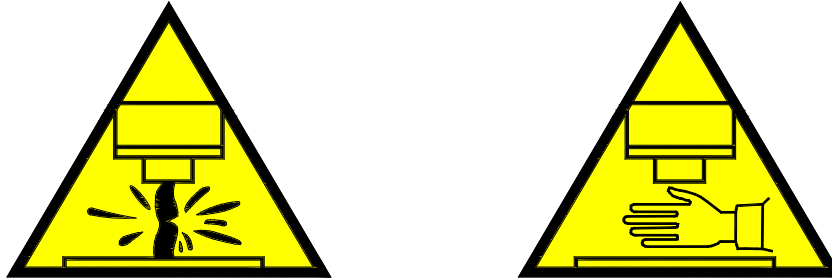

**75**  
**TON**  
**NEVER EXCEED THIS RATED CAPACITY**

**SHOP PRESS**



**WARNING**

- Wear ANSI approved Impact safety goggles, full-face Impact safety shield and heavy-duty work gloves when operating the press.
- Inspect the press before each use. DO NOT use if bent, broken, cracked, leaking or otherwise damaged, any suspect parts are noted or it has been subjected to a shock load.
- Check to ensure that all applicable bolts and nuts are firmly tightened.
- Ensure that workpiece is center loaded and secure.
- Keep hands and feet away from bed area when applying load to the workpiece.
- DO NOT use the shop press to compress spring or any other item that could disengage and cause a potential hazard.
- DO NOT make any modifications to the press.
- Keep children and unauthorized persons away from the work area.
- Failure to heed these instructions may result in property damage and / or serious personal injury.





## TECHNICAL SPECIFICATIONS

Maximum Capacity	75 ton (68 ton)
Hydraulic System Pressure	8691psi. (59.92MPa)
Moveable Cylinder	Yes
Table Width	31.5" (800mm)
Table Depth	11" (279mm)
Cylinder Stroke	9.8" (250mm)
Cylinder Diameter	9" (229mm)
Piston Rod Diameter	3.5" (76.2mm)
Piston Head Diameter	2.75" (69.8mm)
Working Range	2.6" ~ 34.8" (68 ~ 884mm)
Ram Travel Speed	6.75"/min (171mm/min)
Power Requirement	Pneumatic/Manual
Air Fitting	¼"NPT
Air Pressure	107 ~ 124psi. (.75 ~ .85MPa)
Air Volume (minimum)	11.5 SCFM @90psi (.325m <sup>2</sup> @0.62mpa)
Shipping Weight	1300lbs (365kgs)
Shipping Dimensions	84" x 44" x 24" (2134 x 1118 x 610mm)

## TECHNICAL SUPPORT

Our technical support department can be reached at 920.684.4990, and asking for the support desk for purchased machines. Tech Support handles questions on machine setup, schematics, warranty issues, and individual parts needs: (other than die sets and blades).

For specific application needs or future machine purchases contact the Sales Department at: [sales@baileigh.com](mailto:sales@baileigh.com), Phone: 920.684.4990, or Fax: 920.684.3944.



**Note:** The photos and illustrations used in this manual are representative only and may not depict the actual color, labeling or accessories and may be intended to illustrate technique only.



**Note:** The specifications and dimensions presented here are subject to change without prior notice due to improvements of our products.



## UNPACKING AND CHECKING CONTENTS

Your Baileigh machine is shipped complete. Separate all parts from the packing material and check each item carefully. Make certain all items are accounted for before discarding any packing material.

**⚠ WARNING: SUFFOCATION HAZARD!** Immediately discard any plastic bags and packing materials to eliminate choking and suffocation hazards to children and animals.  
If any parts are missing, **DO NOT** place the machine into service until the missing parts are obtained and installed correctly.

### Cleaning

**⚠ WARNING: DO NOT USE** gasoline or other petroleum products to clean the machine. They have low flash points and can explode or cause fire.

**⚠ CAUTION:** When using cleaning solvents work in a well-ventilated area. Many cleaning solvents are toxic if inhaled.

Your machine may be shipped with a rustproof waxy coating and/or grease on the exposed unpainted metal surfaces. Fully and completely remove this protective coating using a degreaser or solvent cleaner. Moving items will need to be moved along their travel path to allow for cleaning the entire surface. For a more thorough cleaning, some parts will occasionally have to be removed. **DO NOT USE** acetone or brake cleaner as they may damage painted surfaces.

Follow manufacturer's label instructions when using any type of cleaning product. After cleaning, wipe unpainted metal surfaces with a light coating of quality oil or grease for protection.



**Important:** This waxy coating is **NOT** a lubricant and will cause the machine to stick and lose performance as the coating continues to dry.





## TRANSPORTING AND LIFTING



**IMPORTANT:** Lifting and carrying operations should be carried out by skilled workers, such as a truck operator, crane operator, etc. If a crane is used to lift the machine, attach the lifting chain carefully, making sure the machine is well balanced.

### Follow these guidelines when lifting with truck or trolley:

- The lift truck must be able to lift at least 1.5 – 2 times the machines gross weight.
- Make sure the machine is balanced. While transporting, avoid rough or jerky motion, and maintain a safe clearance zone around the transport area.
- Use a fork lift with sufficient lifting capacity and forks that are long enough to reach the complete width of the machine.
- Remove the securing bolts that attach the machine to the pallet.
- Approaching the machine from the side, lift the machine on the frame taking care that there are no cables or pipes in the area of the forks.
- Move the machine to the required position and lower gently to the floor.
- Level the machine so that all the supporting feet are taking the weight of the machine and no rocking is taking place.

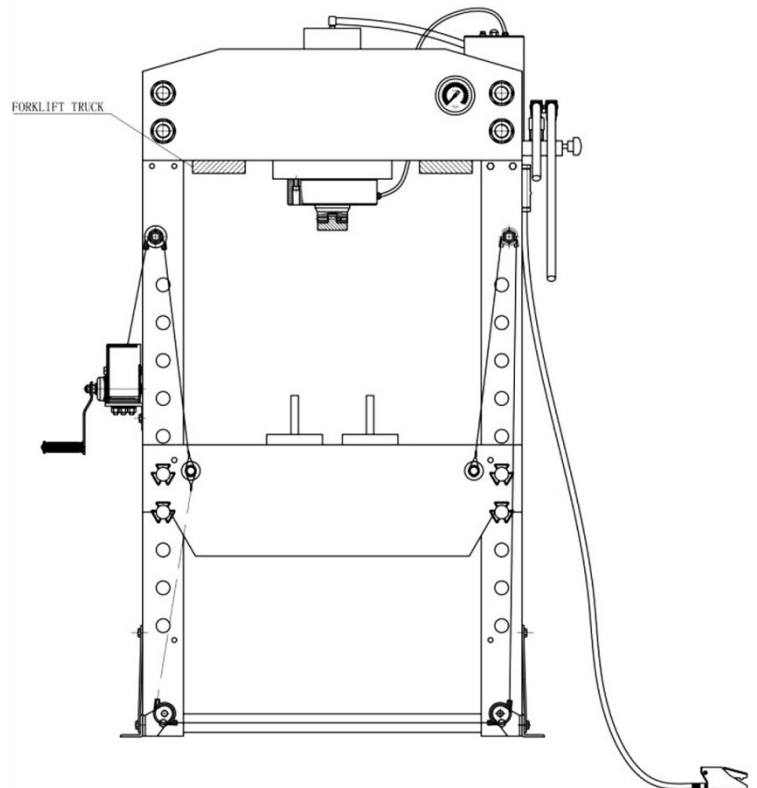
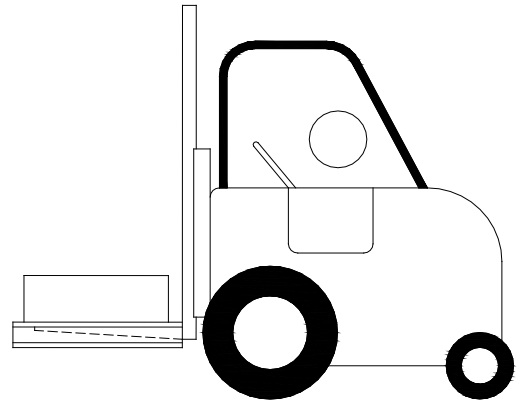



## INSTALLATION

### **IMPORTANT:**

Consider the following when looking for a suitable location to place the machine:

- Overall weight of the machine.
- Weight of material being processed.
- Sizes of material to be processed through the machine.
- Space needed for auxiliary stands, work tables, or other machinery.
- Clearance from walls and other obstacles.
- Maintain an adequate working area around the machine for safety.
- Have the work area well illuminated with proper lighting.
- Keep the floor free of oil and make sure it is not slippery.
- Remove scrap and waste materials regularly, and make sure the work area is free from obstructing objects.
- If long lengths of material are to be fed into the machine, make sure that they will not extend into any aisles.
- **LEVELING:** The machine should be sited on a level, concrete floor. Provisions for securing it should be in position prior to placing the machine. The accuracy of any machine depends on the precise placement of it to the mounting surface.
- **FLOOR:** This tool distributes a large amount of weight over a small area. Make certain that the floor is capable of supporting the weight of the machine, work stock, and the operator. The floor should also be a level surface. If the unit wobbles or rocks once in place, be sure to eliminate by using shims.
- **WORKING CLEARANCES:** Take into consideration the size of the material to be processed. Make sure that you allow enough space for you to operate the machine freely.
- **POWER SUPPLY PLACEMENT:** The power supply should be located close enough to the machine so that the power cord is not in an area where it would cause a tripping hazard. Be sure to observe all electrical codes if installing new circuits and/or outlets.



**WARNING:** Before operating the press, make sure it is firmly anchored to the floor. If it tips over on you, it could cause severe injury or death.



### Anchoring the Machine

- Once positioned, anchor the machine to the floor, as shown in the diagram. Use bolts and expansion plugs or sunken tie rods that connect through and are sized for the holes in the base of the stand.
- This machine requires a solid floor such as concrete at a minimum of 4" (102mm) thick. 6" (153mm) minimum is preferred.

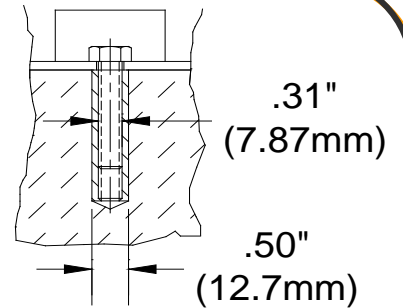

Provide adequate clearance for the equipment in an environment that is clean, non-flammable, non-corrosive, and dust free.

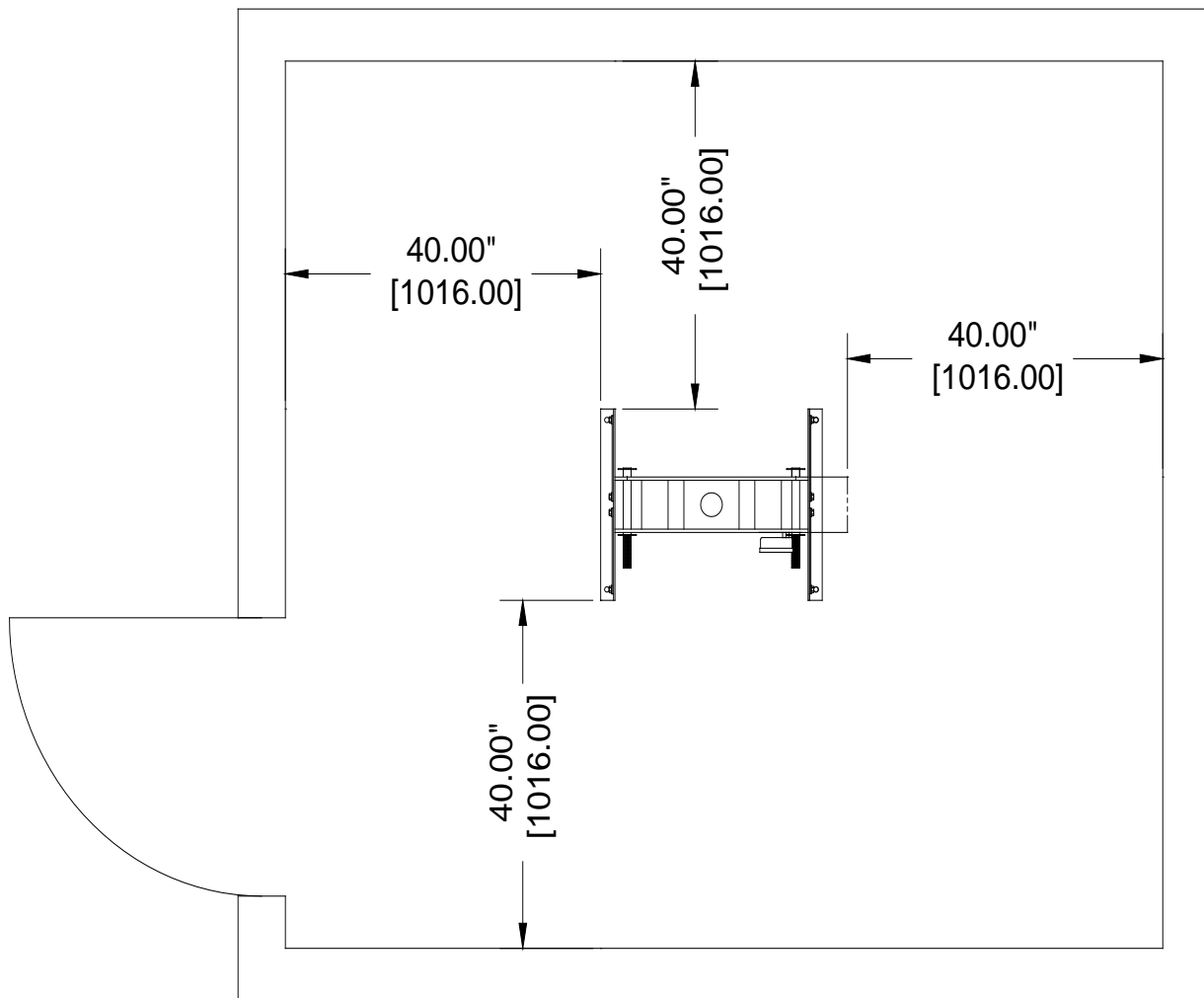



## DIMENSIONS

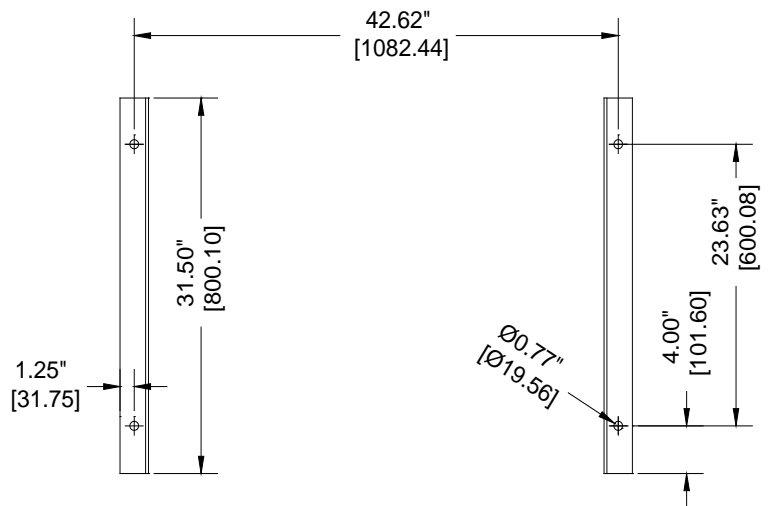
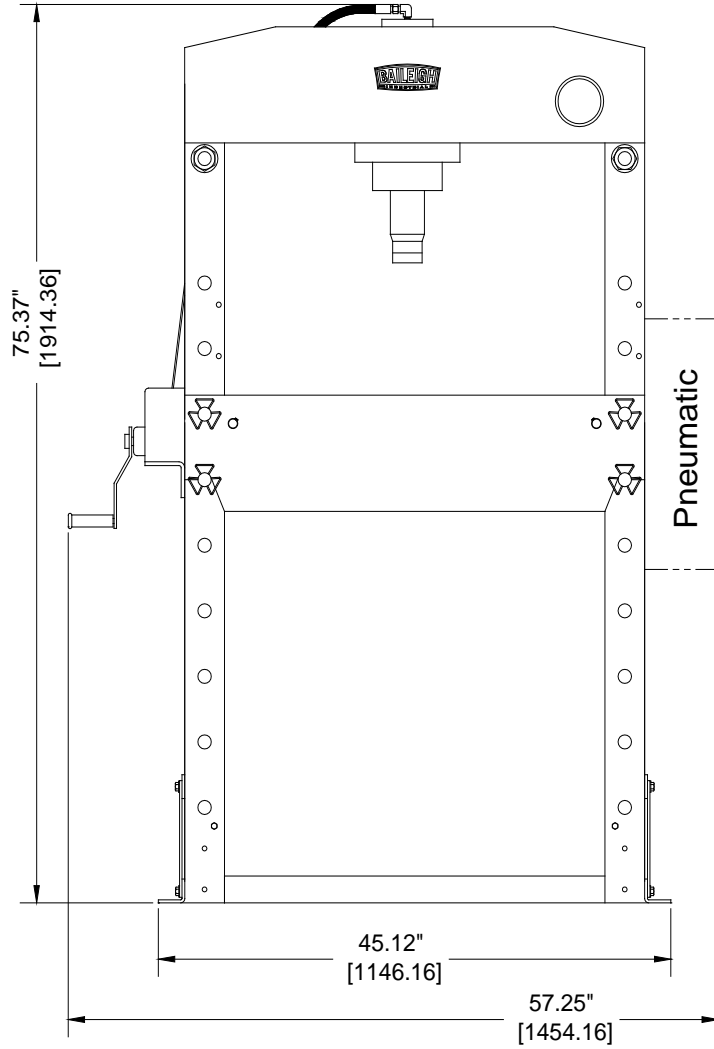
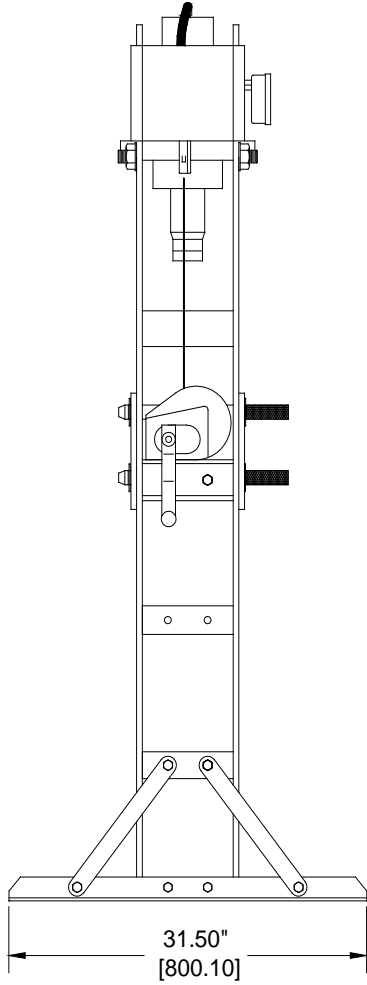



## GETTING TO KNOW YOUR MACHINE

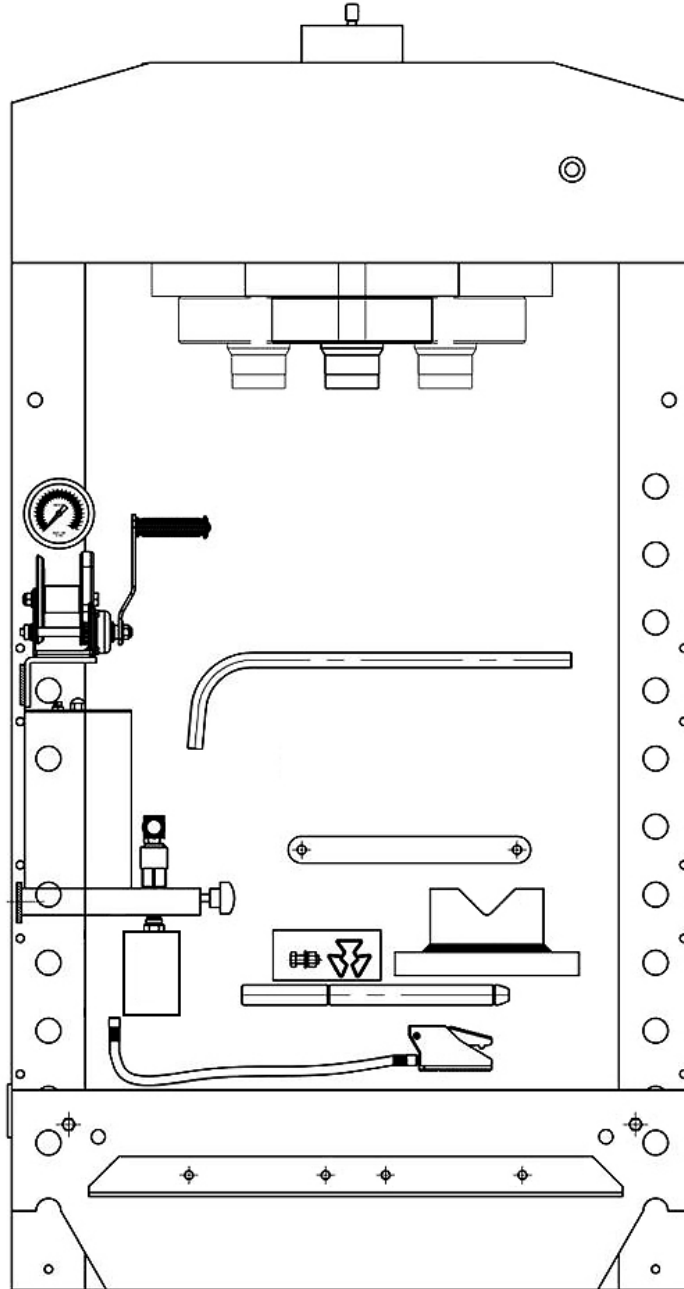

Description	Description	Description
Base Angles	Bed Frame Pin	Circlip
Brace Supports	Bed Frame	Heel Block
Winch and Cable	Hydraulics Pump System	Pressure Gauge
Main Frame w/Cylinder	Handle	Hardware



## ASSEMBLY



**Note:** Reference the Parts Diagram near the end of the book for additional component identification and location.

### Mounting Support Structure

While the base is lying on its side, slide the bed frame from the bottom of the base. This provides for better access when attaching the lower support structure.

1. Attach the base section angle (01) to the main frame with two M12 x 35mm hex bolts (02), flat washers (06), lock washers (05), and nuts (04). Add the two supports (03) with four M12 x 35mm hex bolts (02), flat washers (06), lock washers (05), and nuts (04). Repeat for the opposite side of the base. (Tighten all nuts and bolts securely.)

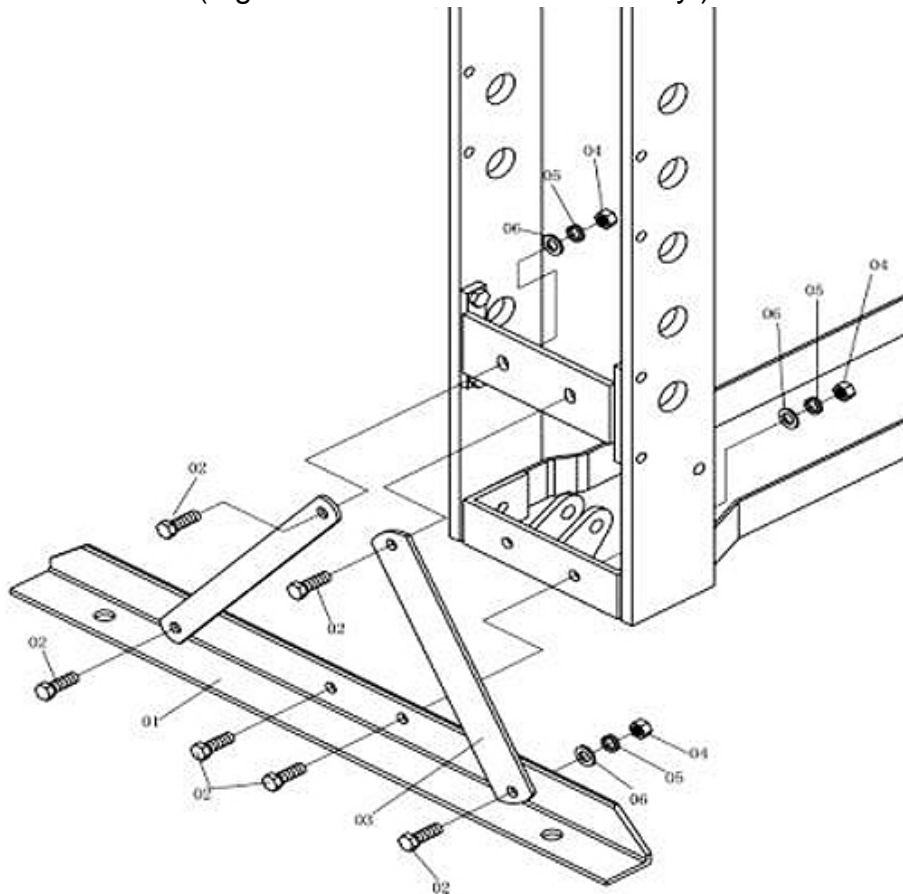

2. Slide the bed frame back down to the bottom of the base before standing the press up. Now using suitable lifting equipment, safely lift the press to a vertical position. Make sure the pneumatic cylinder assembly is supported and not hanging by the hoses which could damage them.



### Attaching the Pressure Gauge

1. Assemble the nylon O-ring (71) inside of the gauge fitting (51), and then install onto the pressure gauge.
2. Install the pressure gauge into the front panel and hold the gauge in position and tighten the nut (52) to hold the gauge in position.

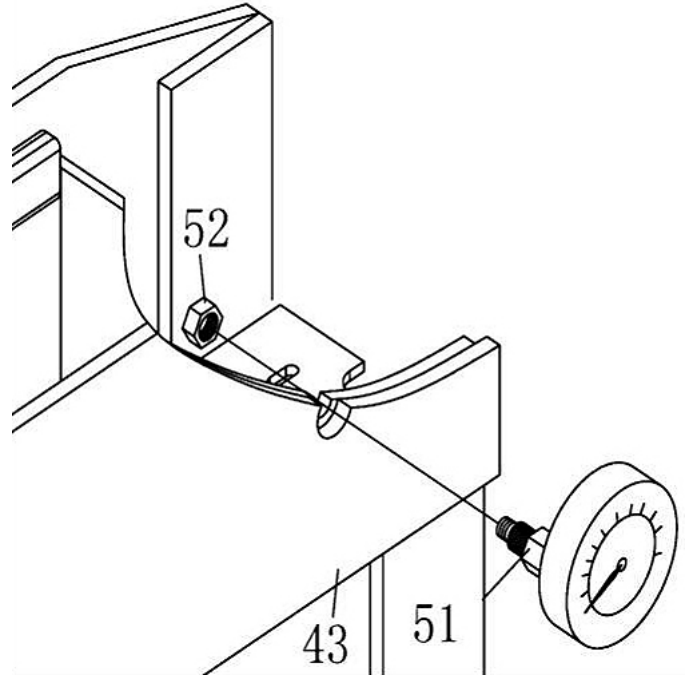

### Install the Hydraulic Assembly

1. Remove the pump assembly (53) from the shipping location inside the press frame.
2. Raise the pump assembly up to the mounting pad and attach the pump assembly (53) to the frame using bolts (54) removed from the shipping location.
3. Tighten the mounting bolts.

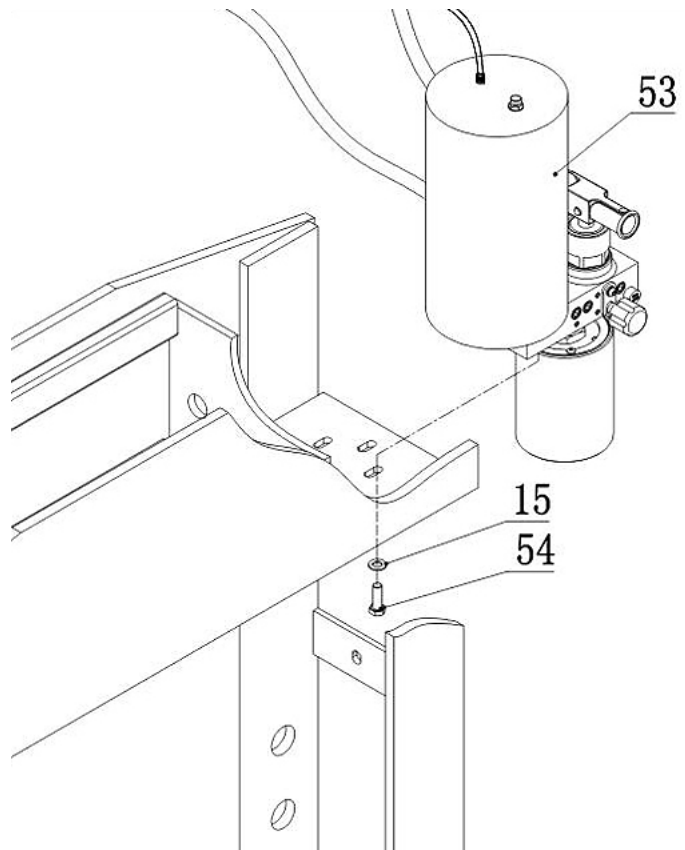



4. Hydraulic hose A (57): Install the O-ring (55) to gauge fitting (51), then put the Hydraulic hose A (57) into the gauge fitting (51) and tighten.

Hose (57) to the pressure gauge, connects to the outboard port of the pump body.

5. Hydraulic hose C (56): Remove the plug from Hydraulic hose (56) then assemble the O-ring (55), also remove the plug from ram assembly (46), and connect the Hydraulic hose 1 (56) to ram assembly (46) and tighten.

Hose (56) to the top of the cylinder, is normally installed on the cylinder and connects to the inboard port of the pump body.

6. Route the PU tube from the cylinder to the top of the hydraulic tank.
7. Remove the plugs from the end of the tube and the elbow fitting on the top of the tank.
8. Install the compression nut from the elbow fitting onto the tube and connect the tube to the fitting.
9. Tighten the compression nut only slightly more than hand tight.
10. Open the breather valve on the top of the tank.
11. Attach the handle to the pump pin by using bolt and tighten.

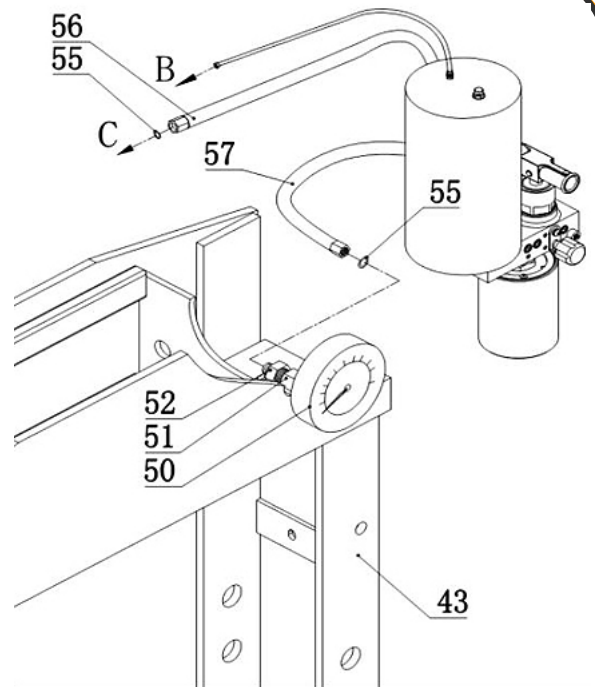



## **Mounting the Bed Frame Winch**

1. Move the hand winch (11) to the outside of the frame and attach the angle to the flatbar member with two M10 x 20mm lg. hex bolts (02), flat washers (06), lock washers (05), and M10 hex nuts (04). Tighten all nuts and bolts securely. Check that the winch cable is not pinched or kinked and that it does not bind up.

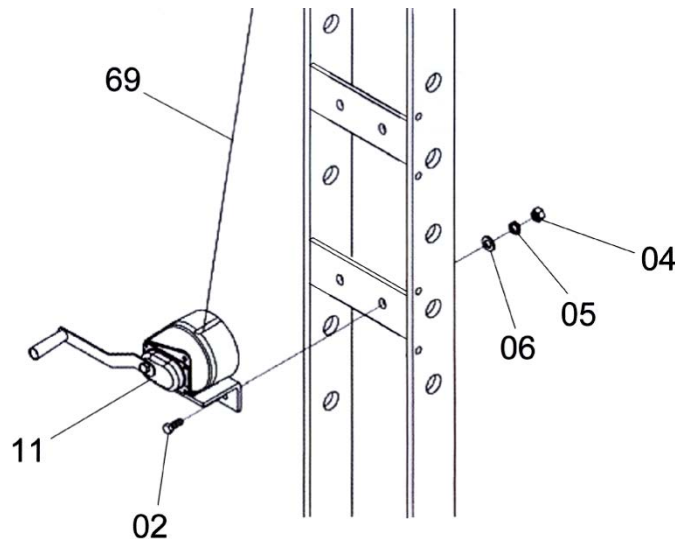

## **SETUP AND ADJUSTMENTS**

### **Ram Slide Adjustment**

To move the ram slide laterally:

1. Loosen the four spring loaded hex bolts.
2. Slide the assembly to a new location.
3. Re-snug the spring loaded hex bolts enough to secure the ram slide.

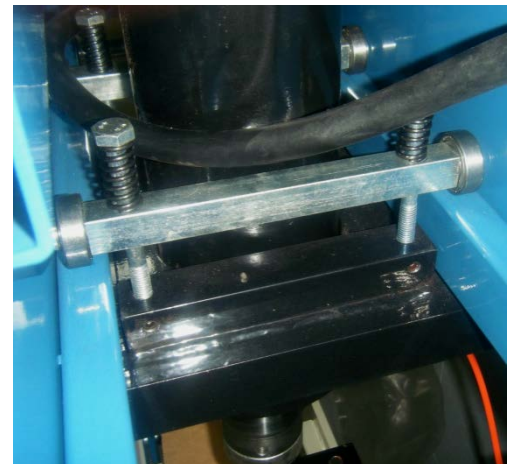



## Purging the System

1. Securely fasten this hydraulic press to a level concrete floor.
2. Make sure there is adequate lighting and a 40" (1,016mm) minimum clearance around the entire machine.
3. Before using for the first time, pour a teaspoon of good quality air tool lubricant into the air supply inlet of the lift control valve. Connect a 120 psi (.83Mpa) airline to the control valve and press the handle for 3 seconds to evenly distribute the lubricant.
4. Purge away air from the hydraulic system.
  - Manual operation system: open the release valve on the pump by turning it counterclockwise.  
Allow the ram to fully retract.  
Close the release valve. Snug but do not overtighten.  
Pump several full strokes to eliminate any air in the system.
  - Air operating system: open the release valve on the pump by turning it counterclockwise.  
Allow the ram to fully retract.  
Close the release valve. Snug but do not overtighten.  
Connect the quick coupler-male into the air supply hose quick coupler.  
Step on the foot pedal to activate the air motor.  
Allow the air motor to extend the ram to full extension.  
Open the release valve on the pump and allow the ram to fully retract.  
Close the release valve. Snug but do not overtighten.

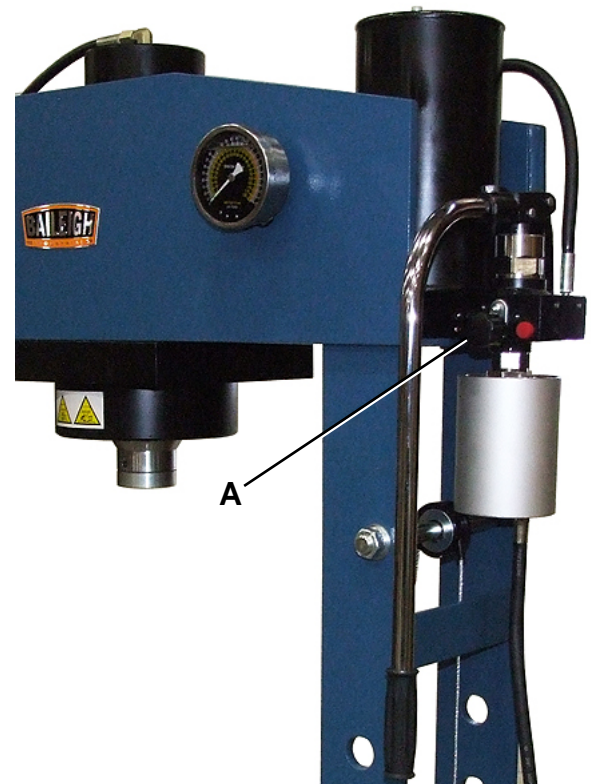
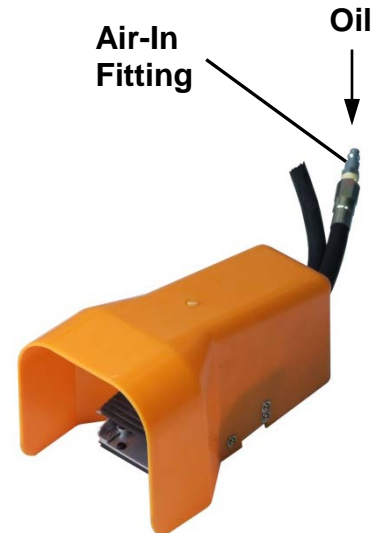



## **OPERATION PREPLANNING**

This is a general discussion on press operation and is not intended to be an exact step-by-step procedure. This is intended to create a broad thought process to be considered prior to using the press to stimulate the operator into thinking about as many possible scenarios that could cause injury or material damage. The operator should then take all steps they can think of to prevent or protect against such possible scenarios

**The following is a listing of some of the most common procedures the operator shall take into consideration and employ. The specific application will require the operator to address any items not covered here.**

1. Provide a container or applicable padding under the press to protect the part when it drops.
2. Position the heel plates to support the workpiece, and aligns the press pin or tooling on the part to be pressed.
3. Preload the workpiece prior to proceeding with the full pressing operation.
4. View the setup from various angles, and verify that the ram remains aligned with and centered with the workpiece and the bed.
5. Relieves the hydraulic pressure and allows the ram to return to the retracted position.



**WARNING:** Failure to center the piece part on the blocks and the ram to the piece part may cause serious injury.

**Never compress springs or objects that when compressed, could shatter, or explode out of the press causing serious injury.**

### **Workpiece Considerations**

Before using this hydraulic press, you must inspect the workpiece. This is not a comprehensive list but rather a list of common issues. It is up to you to address any additional special items required to prepare your workpiece for press operations. Not addressing the items below can lead to galled, seized, or broken housings. Ignoring any of the items listed can lead to a workpiece or tooling being ejected from the press, which could cause severe injury or death.

- **Material Strength:** Make sure that the workpiece material is designed to withstand the intended force the press will apply.
- **Material Cleanliness:** Make sure that the workpiece is clean and that all burrs, grit, rust, or damage is removed from the pressing path. Light oiling on the components may prevent galling or seizing.



- **Pressing Path and Sequence:** Make sure that the direction of the component to be pressed on or off is correct and that the correct size of sleeve or arbor plate is used for support.
- **Fasteners and Retainers:** Make sure that all retaining rings, pins, or fasteners are removed, and no hidden secondary retainers are present.
- **Hidden Objects:** Some components house one or more pieces such as springs, retaining rings, or spacers. Make sure that the part to be dismantled with the press has the applicable caging system to catch hidden items. Should the workpiece slip or open up when the retaining ring is removed and the hydraulic pressure is relieved.
- **Special Fits:** Make sure that interference fits are correct before pressing a part on, and make sure that the applicable parts have been heated or chilled to the correct temperatures to avoid galling and seizing. Be aware, that not all parts were designed to be pressed off. If in doubt, refer to the OEM of the part you are working on.



## OPERATION

**⚠ CAUTION:** Always wear proper eye protection with side shields, safety footwear, and leather gloves to protect from burrs and sharp edges. When handling large heavy material make sure they are properly supported.

### Moving the Bed Frame

**⚠ IMPORTANT:** NEVER lift or lower the bed with tooling or material or pressure from the ram on the bed. This will damage the machine voiding the warranty.

1. Remove all material and the two heel blocks (32) from the bed frame before moving to a different set of holes.
2. In order to reposition the bed frame, have an assistant hold the handle of the winch to keep the frame from falling.
3. Remove the rear circlips (19) and pull out all four bed frame pins (18).
4. Using the winch, either raise or lower the bed frame to a new position and re-insert the pins.
5. Secure with the four rear circlips (19).
6. Place the two heel blocks (32) back onto the frame. They can be used with the flat side up or the V-block side up. Always push the pins down.

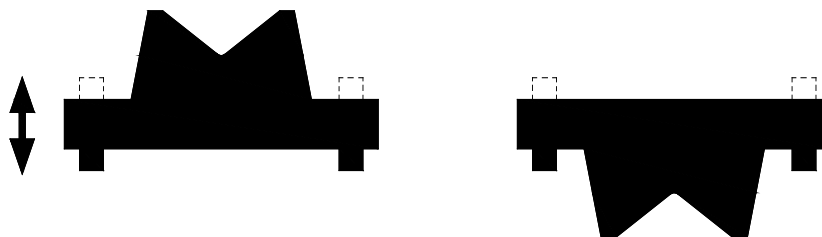

**Note:** The heel blocks should always be used as a pair, not individually.



## Sequence of Operation

1. Insert the piece part into the V-blocks or onto the flat blocks.
2. Close the release valve (P16) by turning it clockwise (cw) until it is off.
3. Connect the quick air valve air-in fitting to a 120 psi (.83 MPa) air source.
4. Press the foot switch on the air valve to let the pump work until the serrated saddle (49) nears the piece part, then release the foot switch. (When an air source is unavailable, pump the handle (64) until the serrated saddle nears the piece part.)



**Note:** When pumping the handle, the pressure will change when the ram contacts the part. The hydraulics is changing from low pressure to high pressure operation. Continue pumping to build pressure to full force.

5. Align the piece part to the ram to ensure center loading.



**WARNING:** Failure to center the piece part on the blocks and the ram to the piece part may cause serious injury.  
Never compress springs or objects that when compressed, could shatter, or explode out of the press causing serious injury.

6. Press the air valve foot-switch (61) or pump the handle (64) to apply load to the piece part. Applied pressure is read on the pressure gauge (50).
7. When the work is done, release the foot switch on the air valve, or stop pumping the handle.
8. Slowly and carefully remove the load from the piece part by turning the release valve (P16) counterclockwise (ccw) in small increments until the ram backs away from the piece part.
9. Once the ram has fully retracted, remove the piece part from the bed frame.
10. Disconnect the air valve from the air source.



## UNDERSTANDING SPRINGBACK

Springback, also known as elastic recovery, is the result of the metal wanting to return to its original shape after undergoing compression and stretch. After the bending leaf is removed from the metal and the load is released, the piece part relaxes, forcing the bent portion of the metal to return slightly to its original shape. The key to obtaining the correct bend angle is to over bend the metal a little and allow it to spring back to the desired angle. All metals exhibit a certain amount of spring back.

## MATERIAL SELECTION

**⚠ CAUTION:** It must be determined by the customer that materials being processed through the machine are NOT potentially hazardous to operator or personnel working nearby.

When selecting materials keep these instructions in mind:

- Material must be clean and dry. (without oil)
- Material should have a smooth surface so it processes easily.
- Dimensional properties of material must be consistent and not exceed the machine capacity values.
- Chemical structure of material must be consistent.
- Buy certificated steel from the same vendor when possible.



## LUBRICATION AND MAINTENANCE



*Note: Proper maintenance can increase the life expectancy of your machine.*

### Daily Maintenance

- Check daily for any unsafe conditions and fix immediately.
- Check that all nuts and bolts are properly tightened.
- Lubricate threaded components pivot points and sliding devices.
- Check hydraulic hoses and fittings for leakage.
- Keep area around machine clear of debris.
- Clean the outside of the press with a clean, soft, and dry cloth.
- When not in use, keep the press dry and covered. Keep the ram and piston fully retracted to prevent rust or corrosion.
- If press efficiency drops, purge air from the hydraulic system.

**DO NOT** allow lubricant on the frame bed or the heel blocks. Wipe off immediately.

### Checking the Hydraulic Oil

- Remove the breather / oil filler nut on top of the reservoir.
- If oil is low, refill with 22 ISO6743 hydraulic jack oil or equivalent. (Reservoir Capacity = 4.7qt (4.5L).
- Replace the oil fill nut.
- Purge air from the hydraulic system.





### Checking the Cable

- Check integrity of bed frame lift system. Make sure cables run free with no binding or twist. Check cable connections and pulleys for wear or damage. **DO NOT** lubricate any part of the lift system.

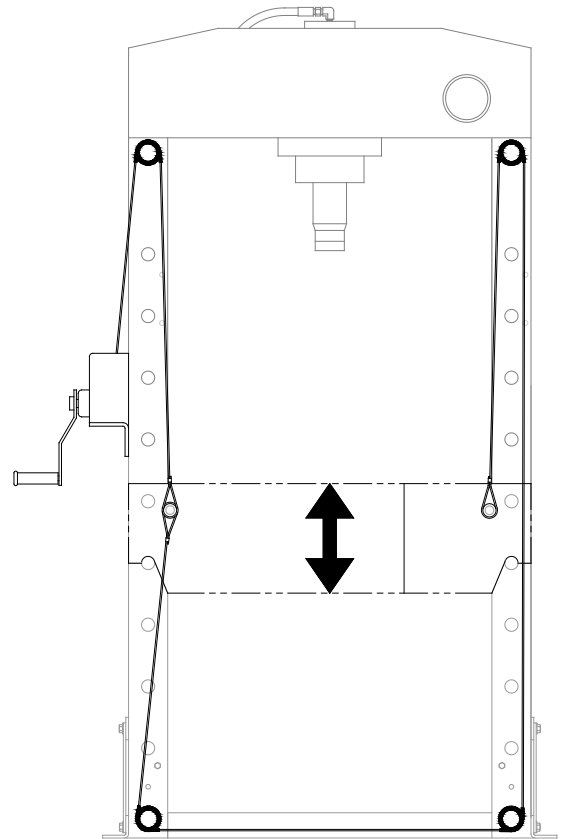



## PARTS DIAGRAM

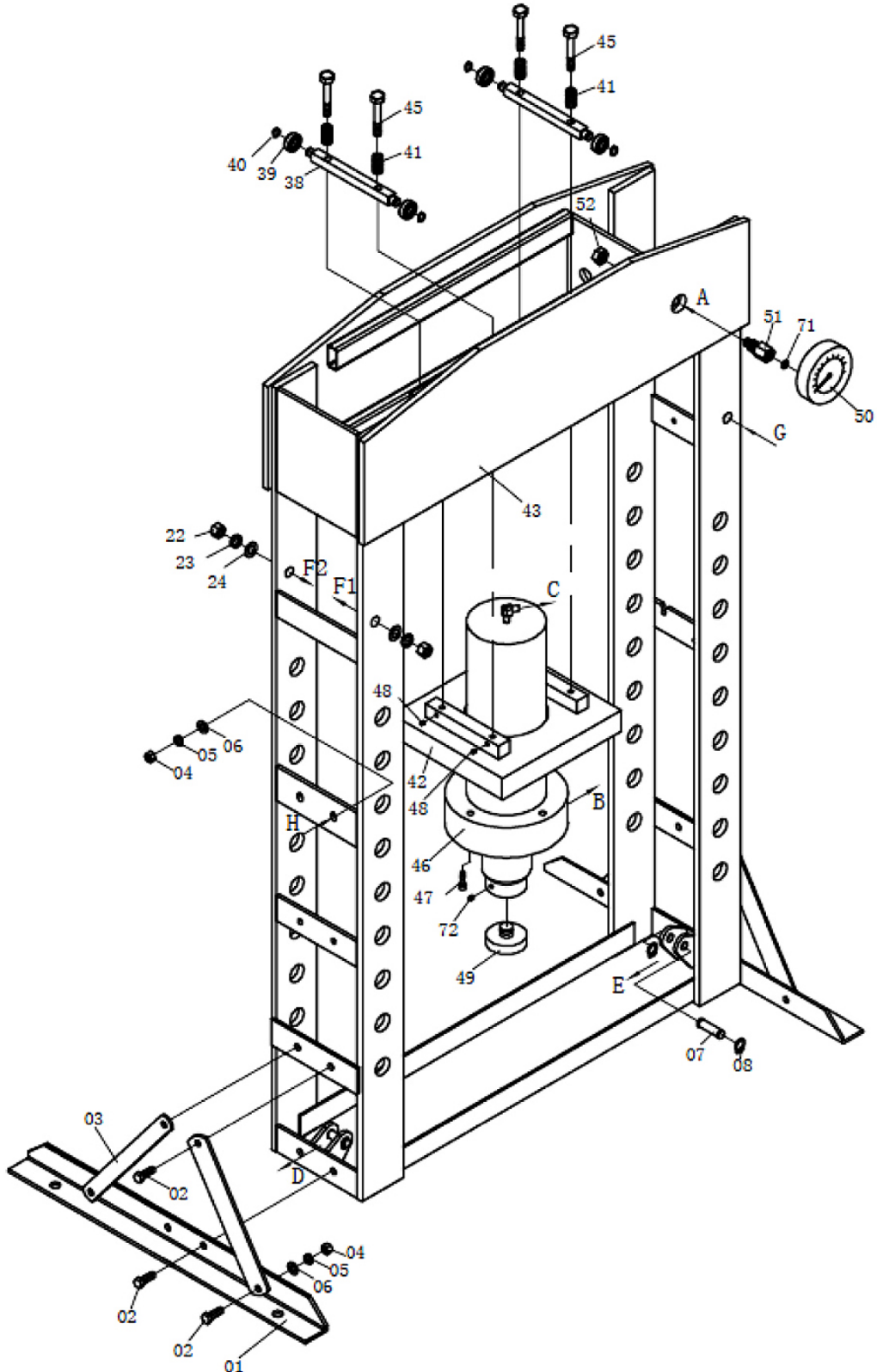

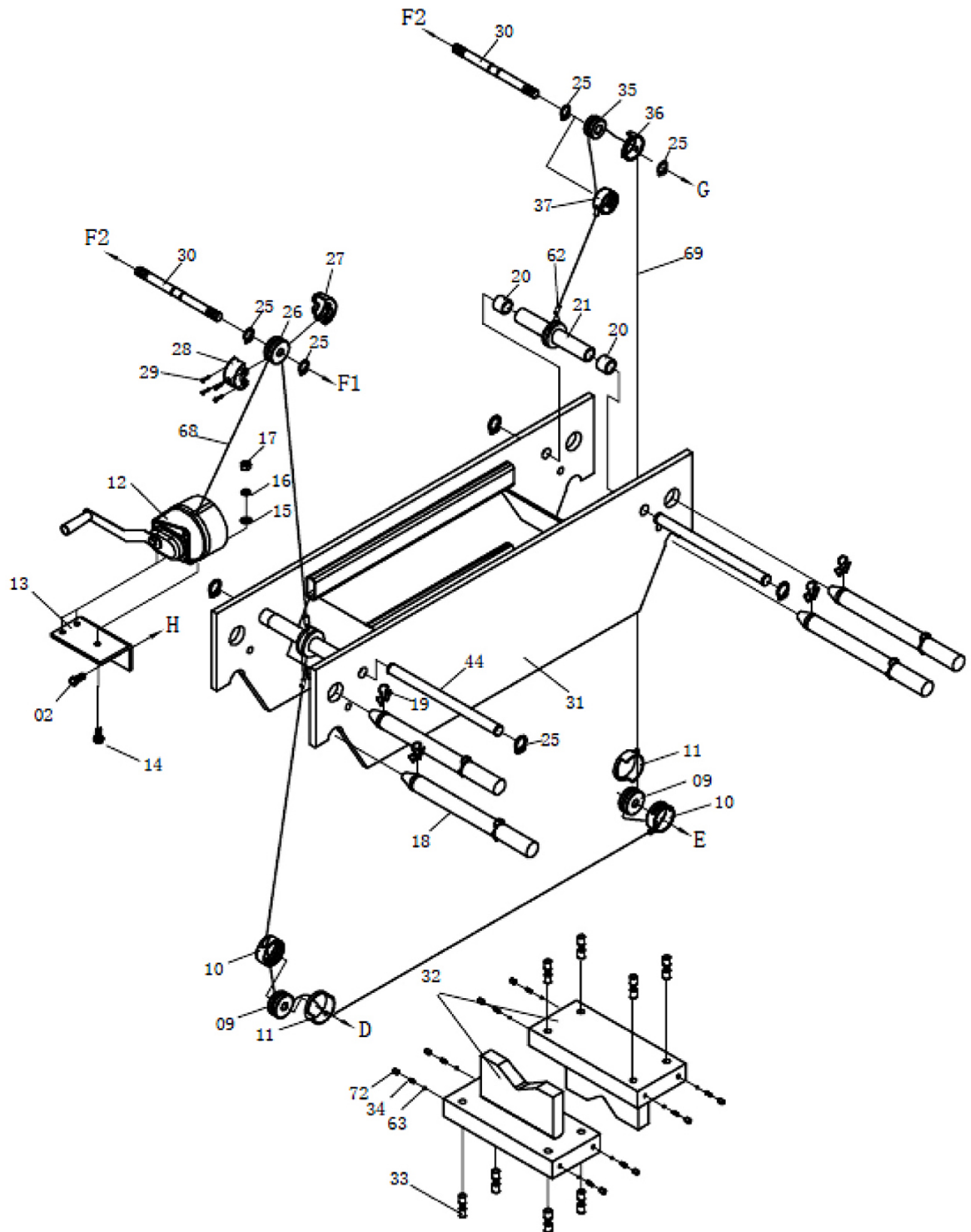

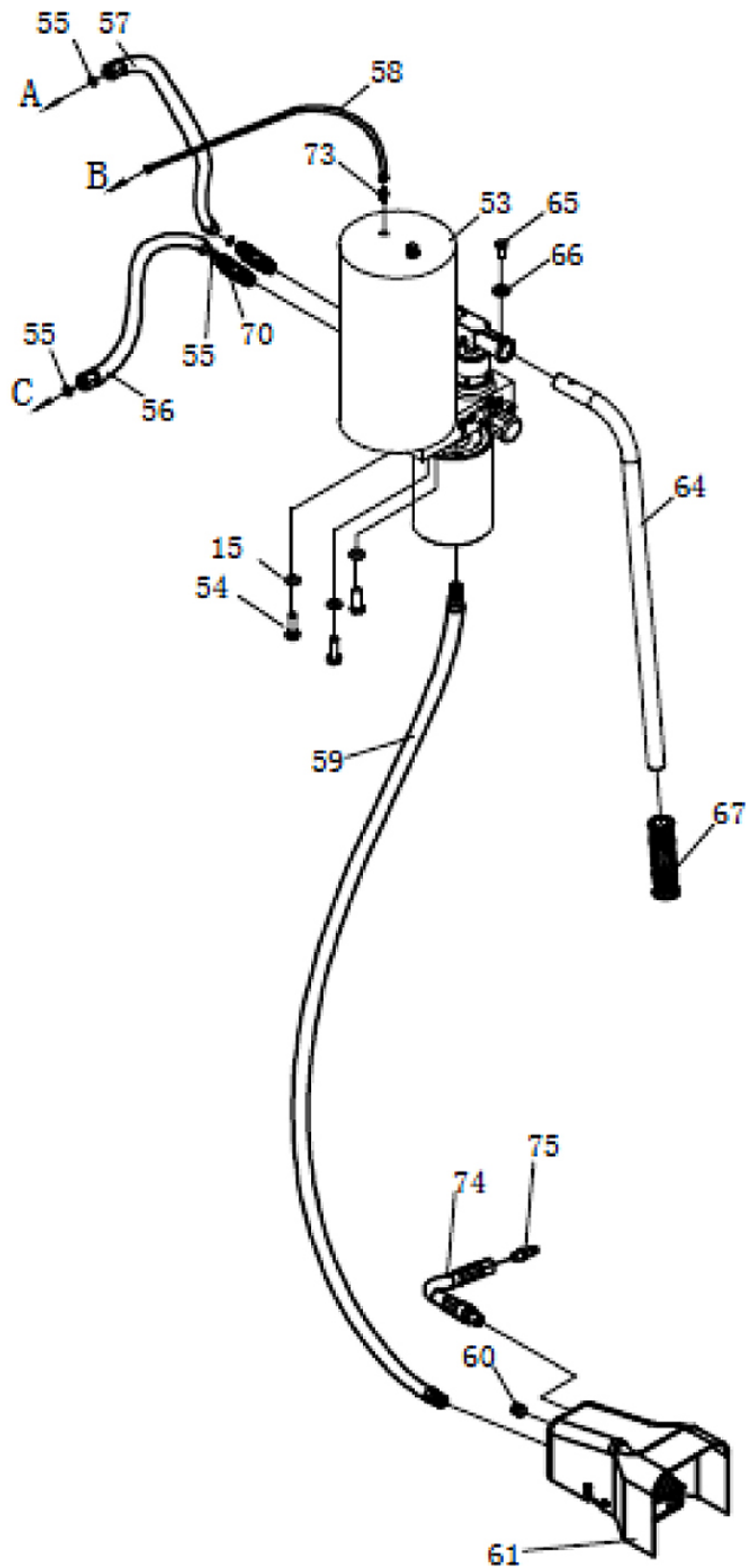



**Parts List**

Item	Description	Qty.
01	Base section	2
02	Bolt	14
03	Support	4
04	Nut	14
05	Lock washer	14
06	Washer	14
07	Pin 2	2
08	Circlip	4
09	Roller	2
10	Shield	2
11	Shield	2
12	Hand winch	1
13	Fixed plate	1
14	Bolt	3
15	Washer	7
16	Lock washer	3
17	Nut	3
18	Pin	4
19	Circlip	8
20	Bushing	4
21	Sleeve	2
22	Bolt	4
23	Lock washer	4
24	Washer	4
25	Circlip	8
26	Roller	1
27	Shield	1
28	Shield	1
29	Screw	4
30	Roller Pin	2
31	Bed frame	1
32	Heel block	2
33	Limited screw	8



Item	Description	Qty.
34	Spring	8
35	Small roller	1
36	Shield	1
37	Shield	1
38	Connecting rod	2
39	Ball bearing	4
40	Circlip	4
41	Spring	4
42	Under plate	1
43	Frame	1
44	Lifting pin	2
45	Bolt	4
46	Ram assembly	1
47	Screw	4
48	Screw	4
49	Serrated saddle	1
50	75T Pressure gauge	1
51	Gauge fitting	1
52	Nut	1
53	Pump assembly	1
54	Bolt	4
55	O-ring	4
56	Hydraulic hose 1	1
57	Hydraulic hose 2	1
58	Oil hose	1
59	Air hose	1
60	Screw	1
61	Air valve with shield	1
62	Cable sheath	3
63	Steel ball	8
64	Handle	1
65	Bolt	1
66	Washer	1
67	Cover for handle	1
68	Cable	1



Item	Description	Qty.
69	Cable	1
70	Elbow	2
71	Nylon ring	1
72	Screw	9
73	Connect fitting	1
74	Air hose	1
75	Hose Fitting	1



# MAIN CYLINDER ASSEMBLY PARTS DIAGRAM

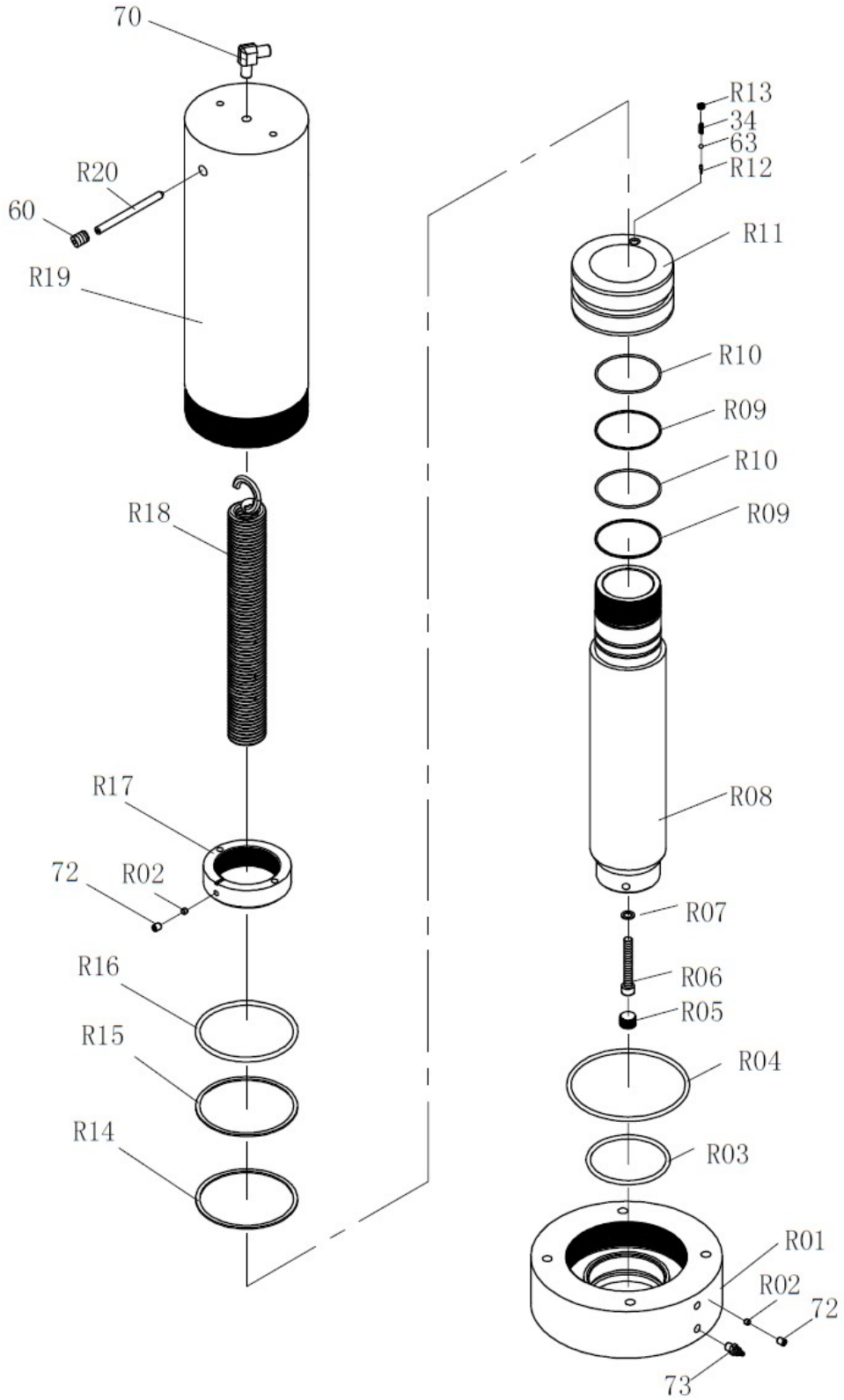



**Main Cylinder Assembly Parts List**

Item	Description	Qty.
R01	Cap fight	1
R02	Nylon ring	2
R03	O-ring	1
R04	O-ring	1
R05	Plug	1
R06	Screw	1
R07	Copper ring	1
R08	Piston	1
R09	F4 ring	2
R10	O-ring	2
R11	Piston head	1
R12	Valve core	1
R13	Screw	1
R14	Nylon ring	1
R15	Retaining ring	1
R16	O-ring	1
R17	Nut	1
R18	Spring	1
R19	Cylinder	1
R20	Pin	1
34	Spring	1
60	Plug	1
63	Steel ball	1
70	Elbow	1
72	Screw	2
73	Connecting fitting	1



# PUMP ASSEMBLY PARTS DIAGRAM

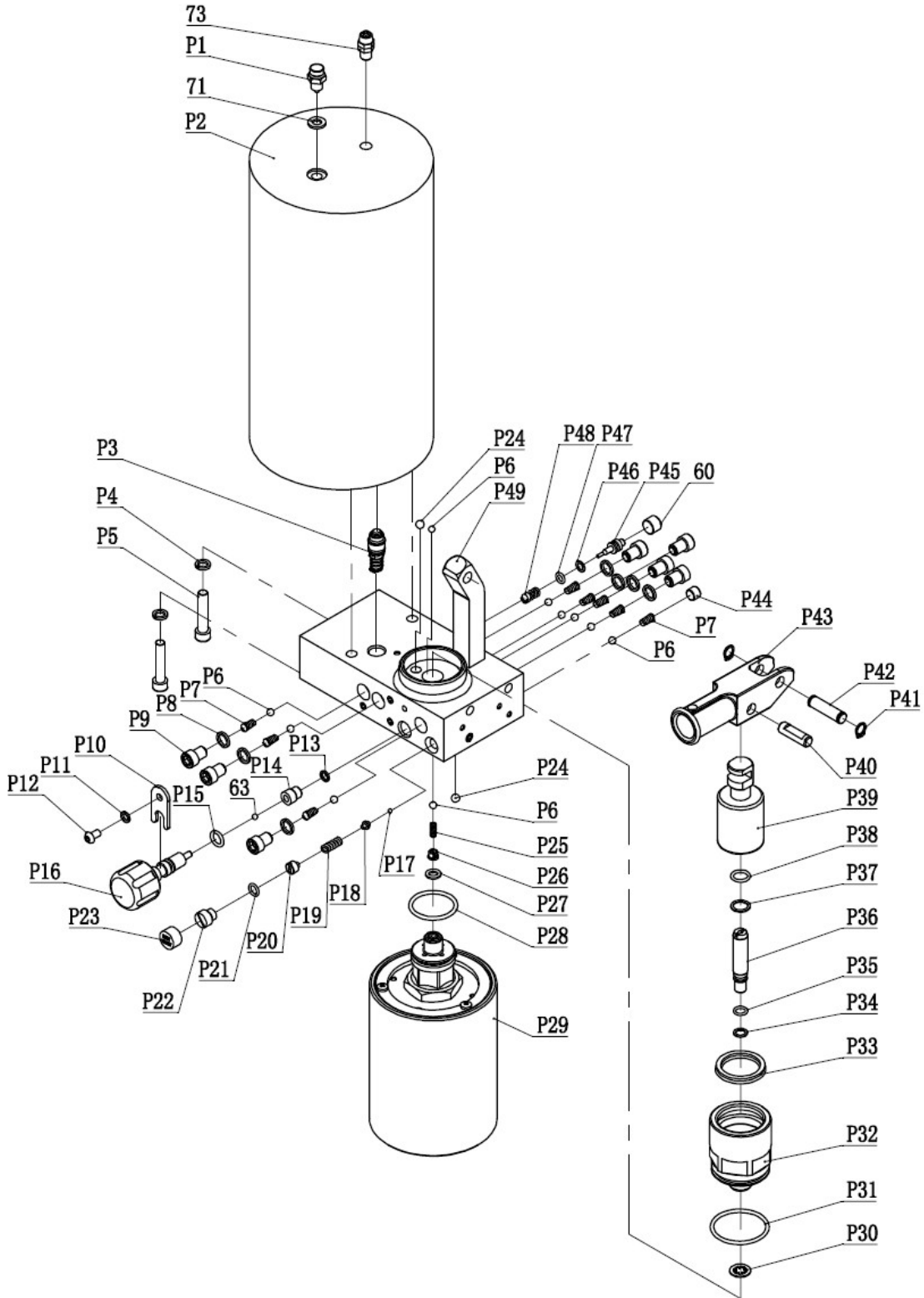



**Pump Assembly Parts List**

Item	Description	Qty.
P01	Vent screw	1
P02	Reservoir	1
P03	Adapter assembly	1
P04	Lock washer	2
P05	Screw	2
P06	Steel ball	10
P07	Spring	8
P08	Copper ring	7
P09	Screw	7
P10	U-ring	1
P11	Lock washer	1
P12	Screw	1
P13	Washer	1
P14	Release Valve seat	1
P15	O-ring	1
P16	Release valve	1
P17	Steel ball	1
P18	Adjust ball seat	1
P19	Spring	1
P20	Screw	1
P21	O-ring	1
P22	Screw	1
P23	Cap	1
P24	Steel ball	2
P25	Spring	1
P26	Spring seat	1
P27	Copper ring	1
P28	O-ring	1
P29	Air motor	1
P30	Copper ring	1
P31	O-ring	1
P32	Pump core base for manual	1
P33	U-ring	1



Item	Description	Qty.
P34	O-ring	1
P35	F4 ring	1
P36	Manual pump core	1
P37	F4 ring	1
P38	O-ring	1
P39	Manual pump core	1
P40	Pin	1
P41	Circlip	1
P42	Pin	2
P43	Hand press	1
P44	Plug	1
P45	Valve plug	1
P46	O-ring	1
P47	F4 ring	1
P48	Spring	1
P49	Weld assembly	1
60	Plug	1
63	Steel ball	1
71	Nylon ring	1
73	Connect fitting	1



HYDRAULIC SCHEMATIC

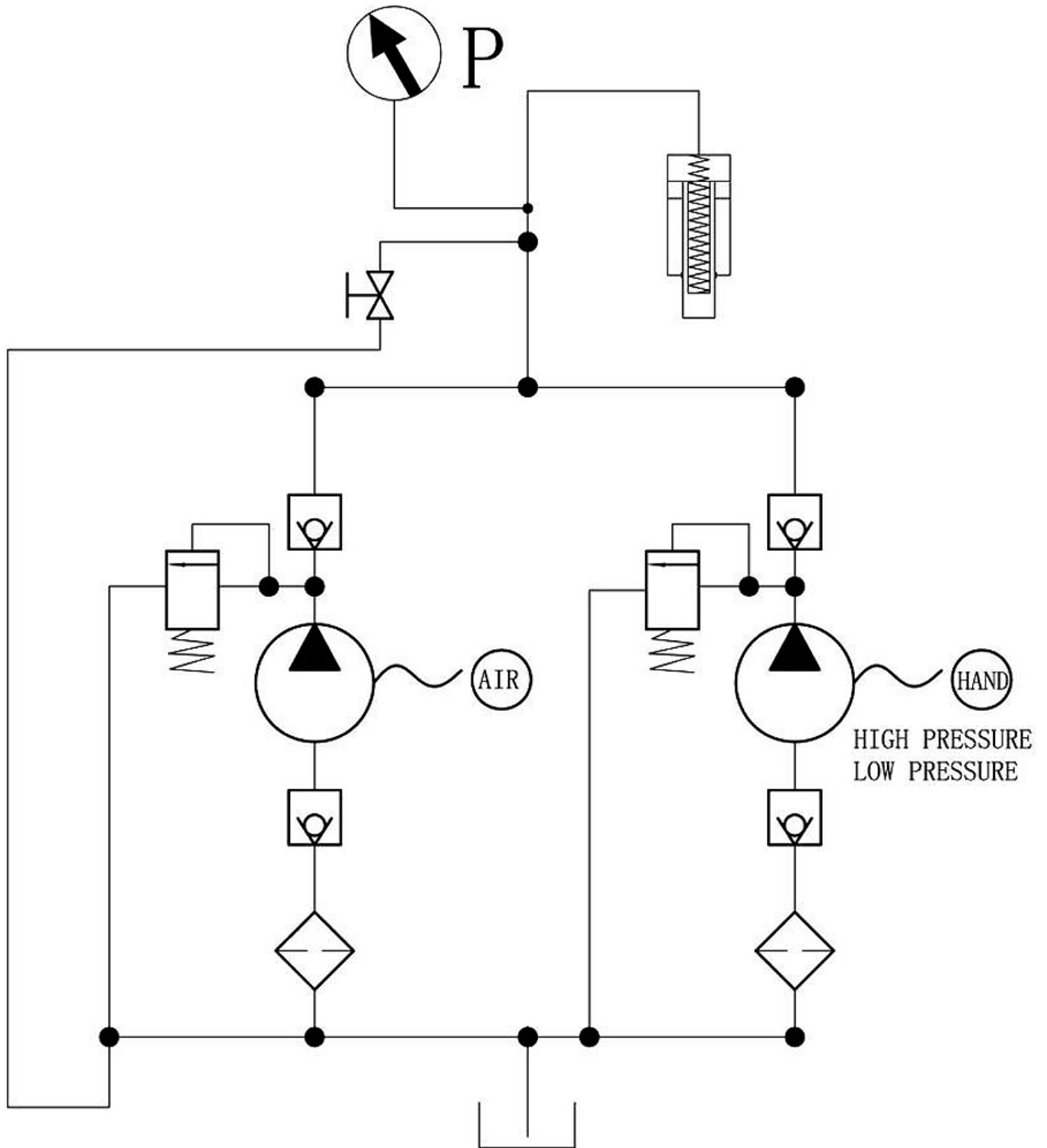



## TROUBLESHOOTING

SYMPTOM	POSSIBLE CAUSE (S)	CORRECTIVE ACTION
Pump is Working But The Ram Will Not Move.	The oil pipe is loose.	Tighten pipe connections.
	The ram is leaking	Replace the oil seals.
When Release Valve is Opened, Ram Does Not Reset.	The oil pipe is loose	Tighten pipe connections.
	Not enough space in the pump.	Open the exhaust valve.
	Ram is damaged	Replace the ram.
Sound From Air Motor But Ram Does Not Work.	Release valve not completely closed.	Check and close the release valve.
	Air in system.	Purge the system
Ram Can Not Complete Stroke.	Not enough hydraulic oil.	Add sufficient oil
Air Motor Does Not Work.	Not enough air pressure or exceeded the capacity.	Check the air pressure and capacity.
	Air motor is damaged.	Replace the air motor.
Leaking oil	Damaged or worn out cylinder seals.	Replace the seals.
	Screwed parts loose.	Re-tighten screws.
	Damaged hose or hoses.	Replace hose(s)



NOTES



**BAILEIGH INDUSTRIAL, INC. 1625 DUFEK DRIVE MANITOWOC, WI 54220**

**PHONE: 920. 684. 4990 FAX: 920. 684. 3944**

**[www.baileigh.com](http://www.baileigh.com)**

**BAILEIGH INDUSTRIAL, INC. 1455 S. CAMPUS AVENUE ONTARIO, CA 91761**

**PHONE: 920. 684. 4990 FAX: 920. 684. 3944**

**BAILEIGH INDUSTRIAL LTD. UNIT D SWIFT POINT**

**SWIFT VALLEY INDUSTRIAL ESTATE, RUGBY**

**WEST MIDLANDS, CV21 1QH UNITED KINGDOM**

**PHONE: +44 (0)24 7661 9267 FAX: +44 (0)24 7661 9276**

**[WWW.BAILEIGH.CO.UK](http://WWW.BAILEIGH.CO.UK)**