



Operating Instructions and Parts Manual

3-in-1 Combination Shear, Brake, Roll

Model SBR-1220



Baileigh Industrial
P.O. Box 531
Manitowoc, WI 54221-0531
Ph.: 920-684-4990
Fax: 920-684-3944
Baileigh-Sales@jpwindustries.com

Edition 2 08/2025
Copyright © 2021 Baileigh Industrial

1.0 Table of Contents

Section	Page
1.0 Table of Contents	2
2.0 Safety Instructions	3
3.0 About This Manual	4
4.0 Product Identification	5
5.0 Specifications	6
6.0 Setup and Assembly	7
6.1 Unpacking and Checking Contents	7
6.2 Cleaning	7
6.3 Installation	7
6.4 Assembly	8
7.0 Shear Overview	8
7.1 Shearing Tips	8
8.0 Shearing Sheet Metal	9
9.0 Shear Adjustments	9
9.1 Adjust for Shear Bow	10
10.0 Removal of Brake Blades for Cleaning and Setup	10
10.1 Installing the Brake Blades	10
11.0 Brake Overview	11
11.1 Bending Allowance	11
12.0 Bending Sheet Metal	11
12.1 Basic Bend Operation	11
12.2 Adjust the Fingers for Box and Pan Bending	11
13.0 Slip Roll Overview	12
14.0 Operating the Slip Roll	12
14.1 Determining Length of Material	12
14.2 Pre-Bending and Finish Rolling	12
14.3 Rolling Operation	12
14.4 Rolling Round Shapes	13
15.0 Material Selection	14
16.0 Maintenance	14
16.1 Lubrication	14
17.0 Slip Roll Maintenance	14
17.1 Every (6) Months Remove and Lubricate the Roller Bushings	14
18.0 Brake Alignment	15
19.0 Replacing the Shear Blade	16
19.1 Rotate or Replace the Blades	16
20.0 Troubleshooting	17
20.1 Shear Operation	17
20.2 Brake Operation	17
20.3 Slip Roll Operation	17
21.0 Replacement Parts	18
21.1.1 3-in-1 Combination Shear, Brake, Roll Assembly – Exploded View	18
21.1.2 3-in-1 Combination Shear, Brake, Roll Assembly – Parts List	19
22.0 Warranty and Service	21



2.0 Safety Instructions

⚠ WARNING

Failure to follow these rules may result in serious personal injury

1. FOR YOUR OWN SAFETY, READ INSTRUCTION MANUAL BEFORE OPERATING THE MACHINE. Learn the machine's application and limitations as well as the specific hazards.
2. Only trained and qualified personnel can operate this machine.
3. Make sure guards are in place and in proper working order before operating machinery.
4. Remove any adjusting tools. Before operating the machine, make sure any adjusting tools have been removed.
5. Keep work area clean. Cluttered areas invite injuries.
6. Overloading machine. By overloading the machine, you may cause injury from flying parts. DO NOT exceed the specified machine capacities.
7. Machine usage. DO NOT use the brake as a press or crushing tool.
8. Dressing material edges. Before bending sheet metal, always chamfer and deburr all sharp edges.
9. Do not force tool. Your machine will do a better and safer job if used as intended. DO NOT use inappropriate attachments in an attempt to exceed the machines rated capacity.
10. Use the right tool for the job. DO NOT attempt to force a small tool or attachment to do the work of a large industrial tool. DO NOT use a tool for a purpose for which it was not intended.
11. Dress appropriate. DO NOT wear loose fitting clothing or jewelry as they can be caught in moving machine parts. Protective clothing and steel toe shoes are recommended when using machinery. Wear a restrictive hair covering to contain long hair.
12. Use eye protection. Always wear ISO approved protective eye wear when operating machinery. Wear a full-face shield if you are producing metal filings. Eye wear shall be impact resistant, protective safety glasses with side shields which comply with ANSI Z87.1 specification. Use of eye wear which does not comply with ANSI Z87.1 specification could result in severe injury from breakage of eye protection.
13. Do not overreach. Maintain proper footing and balance at all times. DO NOT reach over or across a running machine.
14. Stay alert. Watch what you are doing and use common sense. DO NOT operate any tool or machine when you are tired.
15. Check for damaged parts. Before using any tool or machine, carefully check any part that appears damaged. Check for alignment and binding of moving parts that may affect proper machine operation.
16. Observe work area conditions. DO NOT use machines or power tools in damp or wet locations. Do not expose to rain. Keep work area well lighted. DO NOT use electrically powered tools in the presence of flammable gases or liquids.
17. Blade adjustments and maintenance. Always keep blades sharp and properly adjusted for optimum performance.
18. Keep children away. Children must never be allowed in the work area. DO NOT let them handle machines, tools, or extension cords.
19. Store idle equipment. When not in use, tools must be stored in a dry location to inhibit rust. Always lock up tools and keep them out of reach of children.
20. DO NOT operate machine if under the influence of alcohol or drugs. Read warning labels on prescriptions. If there is any doubt, DO NOT operate the machine.
21. Keep visitors a safe distance from the work area.

⚠ WARNING

Before operating the Baileigh Shear, Brake, Roll make sure it is firmly bolted to a table, bench, or the floor. If it tips over on you, it could cause severe injury or death.

⚠ WARNING

The bending brake poses a pinching hazard. The shear blade poses an amputation hazard. Make sure no body part or clothing is near the specific hazard. Failure to follow this warning could result in severed or crushed fingers.

Familiarize yourself with the following safety notices used in this manual:

⚠ CAUTION

This means that if precautions are not heeded, it may result in minor injury and/or machine damage.

⚠ WARNING

This means that if precautions are not heeded, it may result in serious injury or death.

⚠ DANGER

This means that if precautions are not heeded, it will result in serious or fatal, injury.

Save the Instructions

3.0 About This Manual

This manual is provided by Baileigh Industrial, covering the safe operation and maintenance procedures for a Baileigh Model SBR-1220 3-in-1 Combination Shear, Brake, Roll. This manual contains instructions on installation, safety precautions, general operating procedures, maintenance instructions and parts breakdown. Your machine has been designed and constructed to provide consistent, long-term operation if used in accordance with the instructions as set forth in this document.

Technical Support handles questions on setup, operation, schematics, warranty issues, and individual parts needed. Our Technical Support department can be reached at 920-684-4990.

If there are questions or comments, please contact your local supplier or Baileigh Industrial. We can also be reached at our web site: www.baileigh.com.

Retain this manual for future reference. If the machine transfers ownership, the manual should accompany it.

⚠ WARNING

Read and understand the entire contents of this manual before attempting assembly or operation! Failure to comply may cause serious injury!

Register your product online -

<https://baileigh.com/product-registration>



4.0 Product Identification



Figure 4-1

Table 4-1

Item	Description	Function
A	Back Gauge	Controls material stop distance for brake and shear.
B	Rear Roller Adjustment Knob	Clockwise to raise and counterclockwise to lower.
C	Handlebar Adjustment Knob	Loosen knob and adjust handlebar position.
D	Handlebar	Controls motion of the rolls, shear, and brake (the SBR-1220 includes one handlebar).
E	Upper Roller Adjustment Knob	Clockwise to lower and counterclockwise to raise.
F	Slip Roll Cover	Covers rolls when not being used.
G	Slip Roll	Forming material.
H	Brake Fingers	Presses down on the material to form the bend.
I	Shear Adjustment Screws	Adjusting shear blade gap.
J	Work Apron	Place material on this surface when shearing.
K	Shear Blade	Cuts material.
L	Spring Loaded Hold Down	Controls the hold down feed gap.

5.0 Specifications

Table 5-1

Model number	SBR-1220
Power	
Power Requirements	Manual
General Specifications	
Bed Width	12" (305mm)
Shear Capacity	20ga. (.912mm) mild steel*
Bending Capacity	20ga. (.912mm) mild steel*
Rolling Capacity	20ga. (.912mm) mild steel*
Maximum Bend Angle	90°
Slip Roll Solid Rod Sizes	.0625" (1.587mm) diameter, .0937" (2.381mm) diameter, .125" (3.175mm) diameter, .156" (3.968mm) diameter, .187" (4.762mm) diameter, .250" (6.35mm) diameter
Minimum Roll Diameter	1.54" (39mm)
Box Depth	4" (101.6mm)
Frame and Base	Cast Iron
Brake	Ground Steel w/Hardened Edge
Shear Table	Precision Ground Cast Iron
Shear Blades	Hardened Steel (Can be turned four times)
Shear Hold-Down Clamp	Spring-Loaded Cast Iron
Diameter of Rolls	1.5" (38mm)
Weights and Dimensions	
Shipping Dimensions (L x W x H)	20" x 13" x 17" (508 x 330 x 432mm)
Shipping Weight	100 lbs. (45 kg)
Based on a material tensile strength of *64000 PSI – mild steel **100000 PSI – stainless steel	

⚠ WARNING

Read and understand the entire contents of this manual before attempting assembly or operation. Failure to comply may cause serious injury.

6.0 Setup and Assembly

6.1 Unpacking and Checking Contents

The Baileigh Combination Shear, Brake, Roll requires some assembly. After opening the crate, carefully remove and lay out the pieces as shown below and do a visual inventory / inspection. Separate all parts from the packing material and check each item carefully. Make certain all items are accounted for before discarding any packing material.

⚠ WARNING

SUFFOCATION HAZARD! Immediately discard any plastic bags and packing materials to eliminate choking and suffocation hazards to children and animals.

⚠ WARNING

If any parts are missing, **DO NOT** place the machine into service until the missing parts are obtained and installed correctly.



Combination Shear, Brake.

Figure 6-1



Figure 6-2

6.2 Cleaning

⚠ WARNING

DO NOT USE gasoline or other petroleum products to clean the machine. They have low flash points and can explode or cause fire.

⚠ CAUTION

When using cleaning solvents work in a well-ventilated area. Many cleaning solvents are toxic if inhaled.

Your machine may be shipped with a rustproof waxy coating and/or grease on the exposed unpainted metal surfaces. Fully and completely remove this protective coating using a degreaser or solvent cleaner. Moving items will need to be moved along their travel path to allow for cleaning the entire surface. For a more thorough cleaning, some parts will occasionally have to be removed. **DO NOT USE** acetone or brake cleaner as they may damage painted surfaces.

Follow manufacturer's label instructions when using any type of cleaning product. After cleaning, wipe unpainted metal surfaces with a light coating of quality oil or grease for protection.

IMPORTANT: This waxy coating is **NOT** a lubricant and will cause the machine to stick and lose performance as the coating continues to dry.

6.3 Installation

If you intend to mount the Baileigh Combination SBR on a workbench, be aware of the following:

- Overall weight of the machine.
- Weight of material being processed.
- Make sure the workbench is properly reinforced to support the weight.
- The strongest mounting option is where the holes are drilled all the way through the workbench and the machine is secured with bolts, washers, and nuts.

Consider the following when looking for a suitable location to place the machine:

- Sizes of material to be processed through the machine.
- Space needed for auxiliary stands, work tables, or other machinery.
- Clearance from walls and other obstacles.
- Maintain an adequate working area around the machine for safety.
- Have the work area well illuminated with proper lighting.
- Remove scrap and waste materials regularly, and make sure the work area is free from obstructing objects.
- Keep the floor free of oil and make sure it is not slippery.

6.3.1 Leveling

⚠ WARNING

Before operating the Baileigh Shear, Brake, Roll make sure it is firmly bolted to a table, bench, or the floor. If it tips over on you, it could cause severe injury or death.

The machine should be sited on a level, concrete floor. Provisions for securing it should be in position prior to placing the machine. The accuracy of any machine depends on the precise placement of it to the mounting surface.

6.4 Assembly

The handle assembly must be mounted to the machine.

If left hand operation is required, repeat the steps below on the opposite side of the machine.

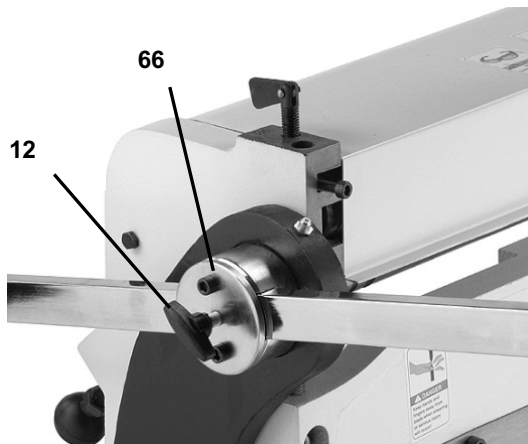

Figure 6-3

1. Install the cover over the handle using two M6-1 x 16 cap screws (#66).
2. Tighten the handle assembly adjustment knob (#12) to fix the handle in position.
3. If needed, extend the handle further from the adjustment knob to obtain greater torque.
4. Thread both rods (#50) into the lower set of holes as shown in (fig.6-4). These holes are located on the out feed side of the casting. With the flange pointing up, the stop assembly is used for the brake. If the flange points down, the stop assembly is used for the shear.
5. Fasten both stand dies (#49) to the back gauge (#48). The stand dies can now be positioned where needed on the long rods to locate the back gauge.



Figure 6-4

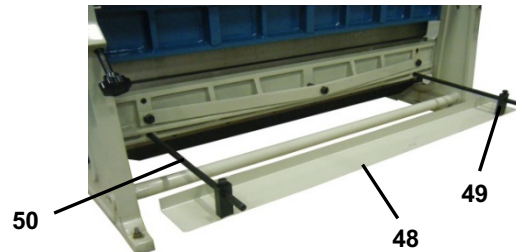

Figure 6-5

7.0 Shear Overview

The shear section has blades that can be reversed to provide a sharp edge as needed and are capable of shearing up to 20 gauge (0.912mm) mild steel sheet x 12" (305mm) wide. An adjustable upper blade assembly passes by a fixed lower blade resulting in a precise shearing action. If necessary, the back gauge can be adjusted to accommodate repeat pieces.

7.1 Shearing Tips

1. Keep the blade gap to the smallest distance possible.
2. When shearing, the work should be squared against a guide.
3. The pressure plate should be adjusted approximately 0.125" (3.175mm) above the table when the shear blade is in the up position. As the blade is moved downward, the pressure plate should immediately rest against the workpiece and hold it in place.
4. To prevent distortion when shearing, snap the handle assembly quickly to pierce the workpiece, then continue with steady even pressure to complete the cut.
5. After shearing, metal parts will have a sharp edge on them. These edges may cause cuts when handled. Deburr the workpiece to remove the edge before handling.

6. Have the shear blades sharpened by a professional. This will lead to accurate, quality results.
7. To avoid rolling over the edge of the sheet metal and pinching it between the two blades, NEVER cut any piece narrower than eight times the thickness of the material.

8.0 Shearing Sheet Metal

⚠ WARNING

Before operating the Baileigh Shear, Brake, Roll make sure it is firmly bolted to a table, bench, or the floor. If it tips over on you, it could cause severe injury or death.

⚠ WARNING

The shearing blades pose an amputation hazard. Make sure no body part or clothing is near the specific hazard. Failure to follow this warning could result in severed or crushed fingers.

⚠ CAUTION

Always wear proper eye protection with side shields, steel toe footwear, and leather gloves to protect from burrs and sharp edges.

1. Adjust the rear stop (#48) to accommodate the length of the cut (fig. 8-1).

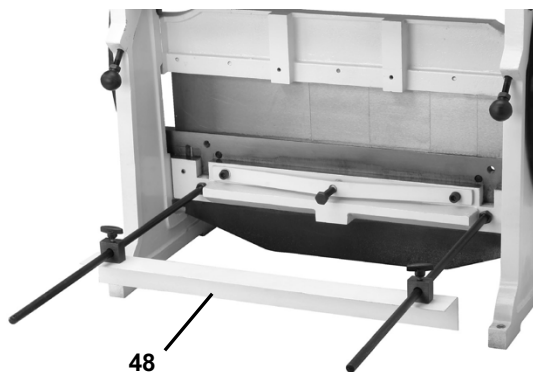

Figure 8-1

2. Using the handle assembly, raise the upper blade to the highest position.
3. Have at least one square edge of the material against the side guide or the adjustable rear stop for accurate cuts.
4. Lay the sheet metal on the work apron against the left side guide. Push the sheet under the hold down until it bumps up to the adjustable stop.
5. Rotate the handlebar to begin the cut. The shearing action begins at the left side of the

piece part and continues to the right until the cut is complete.

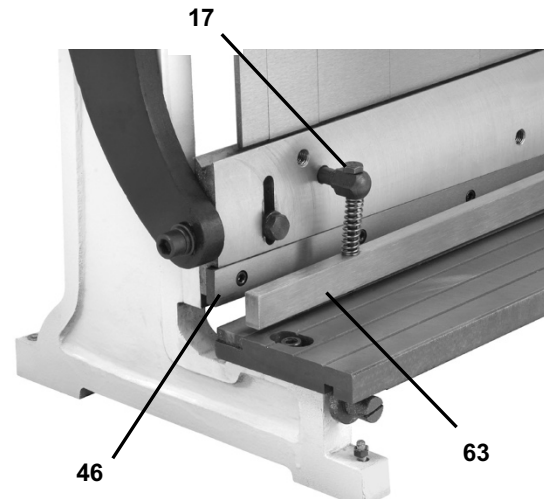

Figure 8-2

- a. The pressure plate (#63) should make contact with the sheet before the blade (#46) does. If it does not, adjust the two hex bolts (#17) on the pressure plate brackets to lower the pressure plate. When fully open the gap should not exceed 0.125" (3.175mm).
6. Carefully lift the cut piece from the rear of the machine if it does not fall to the tabletop or floor on its own.

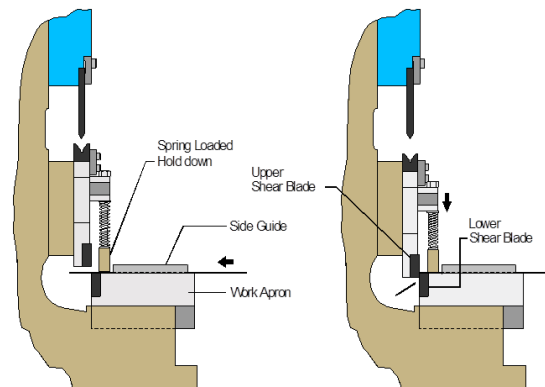

Figure 8-3

9.0 Shear Adjustments

To obtain optimum results, shear alignment and shear bow are two conditions which may need to be adjusted depending on the gauge and type of material you want to shear. Shears that are out of adjustment may lead to uneven or ragged cuts.

1. Lower the shear and hold it in position.
2. Measure along the length of the blades, check the gap of the moving blade and the fixed blade with a 0.002" (.05mm) feeler gauge as shown in figure 9-1.

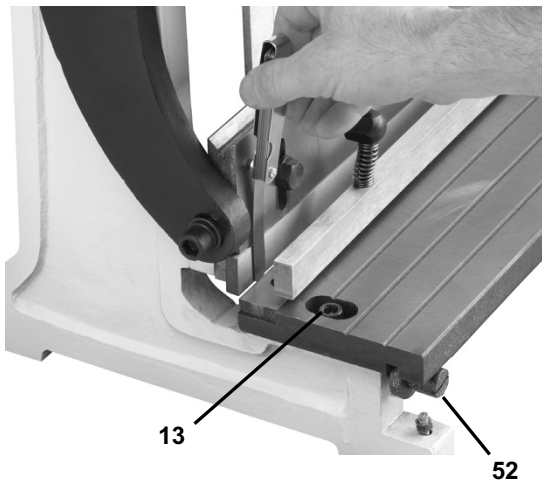

Figure 9-1

- If the gap is the same along the length of the blades, then no further adjustment is needed.
 - If the gap is unequal, proceed to **Step 3**.
 - If you detect a bow in the gap, read the next sub-section on shear bow.
3. Loosen the two cap screws (#13) that hold the table in place (fig. 9-1).
 4. Turn the two adjustment screws (#52) (one on each end of the work apron) until the gap is equal across the length of the blades.
 5. Tighten the two table adjustment screws and re-check.

9.1 Adjust for Shear Bow

Make small adjustments to the bolt attached to the shear blade adjustment bar.

1. Tighten the adjustment bolt (#26) to cause the ends of the upper blade to move away from the fixed blade or loosen the bolt to cause the ends of the upper blade to move toward the fixed blade.
2. Once the shear bow is corrected, re-check the shear gap.

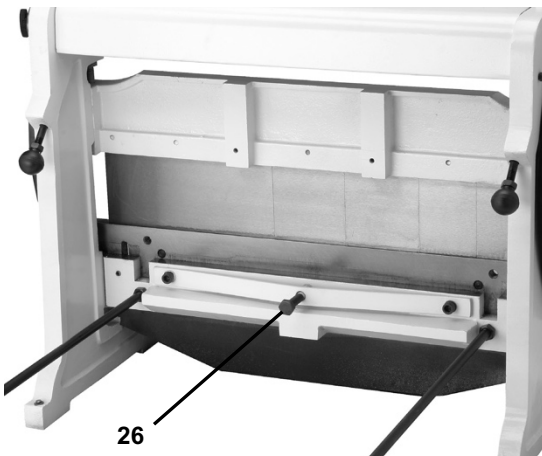

Figure 9-2

10.0 Removal of Brake Blades for Cleaning and Setup

Turn the handlebar counterclockwise (**ccw**) to raise the brake blade die until it contacts the brake blades as shown in (fig.10-1). Using a hex wrench, loosen all cap screws holding the gib. Now slide the brake blades out, one at a time. Clean the casting seat, the gib, and all of the brake blades with mineral spirits. After drying, lubricate with an anti-rust lubricant.

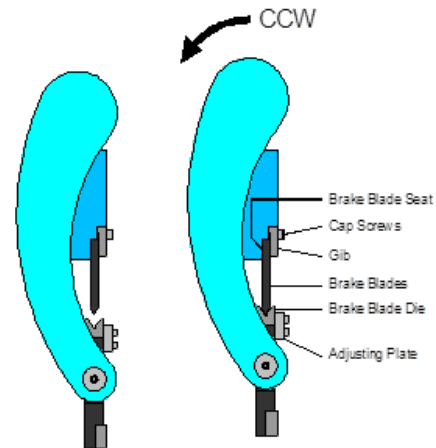

Figure 10-1

10.1 Installing the Brake Blades

Turn the handlebar clockwise (**cw**) to lower the brake blade die. Lay a strip of wood on the brake blade die the full length as shown in (fig.10-2). Start inserting the brake blades. Wide blades to the right and narrow blades to the left when facing the front of the machine. When the brake blades are all in place, turn the handlebar counterclockwise (**ccw**) to raise the brake blade die. When the brake blades are firmly seated in the casting, tighten all cap screws on the gib. Now lower the brake blade die and remove the strip of wood.

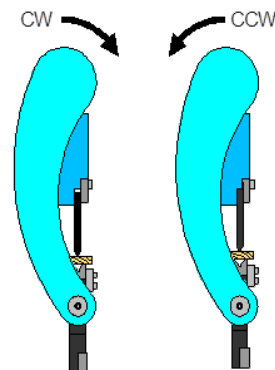

Figure 10-2

11.0 Brake Overview

The Combination SBR has adjustable and removable fingers to offer a wide variety of bending brake options. The brake section is capable of bending up to 20ga. (0.912mm) x 12" (305mm) wide mild steel sheet.

To start a bend, the operator places a piece of sheet metal on the blade brake die. By turning the handlebar, the brake die is raised up until the tips of the brake blades line up with a line scribed on the sheet metal. If necessary, the back gauge can be adjusted to accommodate repeat pieces. By continuing the upward travel of the brake die, the brake blades push the sheet metal down into the "V"-groove of the brake die. The thinner the material the further it will enter the groove for a slight overbend. This is helpful when the material experiences some springback. To remove the piece part, the operator lowers the brake die and removes the piece from the front of the machine.

11.1 Bending Allowance

To bend sheet metal accurately, you will need to consider the total length of each bend. This is referred to as bend allowance. Subtract the bend allowance from the sum of the outside dimensions of the piece part to obtain the actual overall length or width of the piece. Because of differences in sheet metal hardness, and whether the bend is made with the grain or against it, exact allowances must sometimes be made by trial and error. However, bend allowances for general use can be obtained from metal working books or from the Internet.

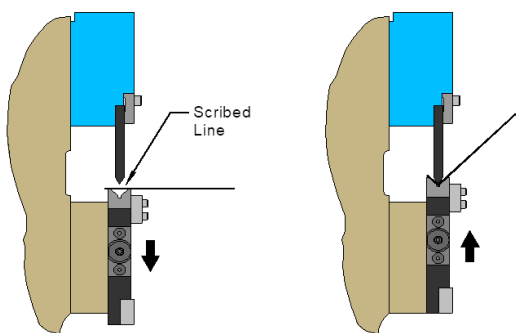

Figure 11-1

12.0 Bending Sheet Metal

⚠ WARNING

Before operating the Baileigh Shear, Brake, Roll make sure it is firmly bolted to a table, bench, or the floor. If it tips over on you, it could cause severe injury or death.

When using the Combination SBR as a manual box and pan brake, the brake blades can be removed and setup to allow all four flanges of the box or pan to be bent upward.

12.1 Basic Bend Operation

⚠ WARNING

The bending brake poses a pinching hazard. Make sure no body part or clothing is near the specific hazard. Failure to follow this warning could result in severed or crushed fingers.

1. Install the stop assembly in the holes in the brake die as shown in fig 12-1. Adjust the stop to the required depth. It can also be mounted on the front of the brake. Or. Scribe a line on the sheet metal to indicate where the bend is to be made.



Figure 12-1

2. Using the handle assembly, raise the fingers on the brake until there is enough gap to fit the work piece.
3. Lower the brake blade die by turning the handlebar and inserting the sheet metal between the brake die and the brake blades.
4. Make sure the material is against the back stop or that the scribe mark is lined up to where the brake blade will come down.
5. While the sheet metal is being held firmly, turn the handlebar and make the bend to the desired angle.
6. Raise the brake blade die and remove the piece part

Note: The brake die is designed to bend material up to 90°.

12.2 Adjust the Fingers for Box and Pan Bending

1. Place a thin and flat piece of spacer material (A) over the notch of the brake die. This flat surface will help you obtain equal finger length.
2. With the handle assembly, lower the fingers so they are just touching the top of the spacer on the brake die.

- Loosen, but do not remove, the six cap screws (#20) shown in fig 12-2

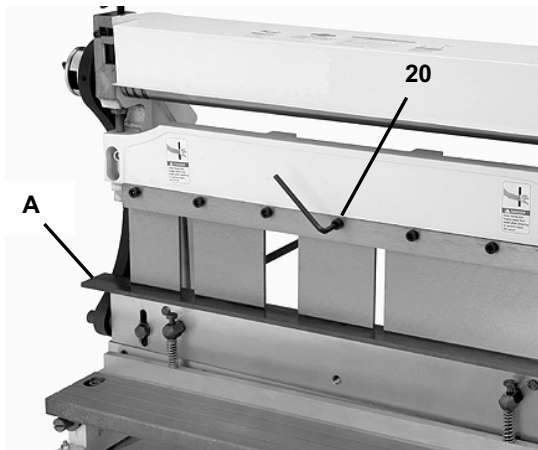

Figure 12-2

- Slide the fingers horizontally to the desired position or rearrange them to get the desired width combination for your project.
- Using the handle assembly, lower the fingers to apply light pressure. Check to make sure each finger has continuous contact with the spacer.
- Tighten the six cap screws.

13.0 Slip Roll Overview

The slip roll section can be used to roll up to 20ga. (0.912mm) x 12" (305mm) wide mild steel. It consists of 3 hardened rolls. The rear roll is adjustable to control the radius of the piece part as it is being formed. The closer the rear roll is brought to the front upper roll, the tighter the radius. The two front gear driven rolls pinch the material and pull it against the rear roll, forcing it up towards the front upper roll. The top front roll has two adjustment knobs, one on each end of the machine, to control the upper and lower roller spacing for different material thicknesses. When removing the formed piece part, the top front roll can be slipped out.

- When the slip roll section is not being used, the operator can cover the rolling mechanism with the formed steel pivoting cover / guard.
- The rear roll can be adjusted to a raised or tilted position on one end to roll cones or left flat to roll cylinders or arcs.
- Located on the end of the upper and lower rolls are three wire or forming grooves. These can be used for forming small diameter tubing or wire into rings or curved shapes.
- To prolong the life of the rolls, always keep them clean and well lubricated. Remove burrs from the edges of any sheet metal being processed through the rolls.
- DO NOT exceed the rated capacity on this slip roll. It has been tested at the factory to roll 20ga. (.912mm) x 12" (305mm) wide mild steel.
- Because material springback varies with the kind of material being formed, only by test

forming several pieces can the correct adjustments be made.

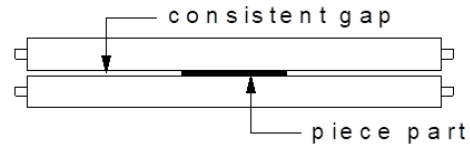

Figure 13-1

CAUTION

When handling large piece parts, you may require assistance in handling the piece as it exits the rolls. Failure to adequately support the piece part may result in the piece falling and causing bodily injury.

14.0 Operating the Slip Roll

14.1 Determining Length of Material

LENGTH OF MATERIAL necessary to form the desired size circle is the first consideration in circle forming. To determine the approximate length of material needed use the formula: $C = \pi \times D$, Where C is the circumference, π is the value of π or 3.1416, and D is the diameter. For example, to find the length of material (C or Circumference) to form a 4" (101.6mm) diameter circle, multiply (3.1416 x 4). The result is 12.5664 or the approximate length of material needed. Cut a few pieces of material to this length for test forming. Material may have to be lengthened or shortened depending upon results of the test forming run.

14.2 Pre-Bending and Finish Rolling

PRE-BENDING is the operation where the ends of the material are bent to the same radius as that of the finished piece. This principle is used to get the best results in full circle bending.

Before bending, follow these steps:

- Clean the material and rolls of any dust or grease.
- Make sure the edges of the piece part are free of chips and burrs.
- Check that the material is flat.
- Have a template of the finished diameter to compare with.
- Always work in the center of the rolls.

14.3 Rolling Operation

- Back off the idler roll by turning the two adjustment bolts counterclockwise (ccw) as in view "A" below.
- Unscrew the top roll adjustment bolts until there is enough gap between the top and bottom rolls to allow the piece part to fit between.
- Rotate the handlebar to advance the piece part about 1" (25.4mm) beyond the rolls.

4. Tighten the top roll adjustment bolts to hold the piece part firmly.
5. Raise the idler roll enough to get the material started in an upward direction against the top front roll as shown in view "B".
6. Rolling the initial edge slightly will give it a pre-bend.

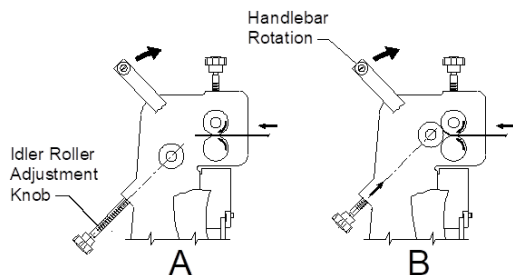

Figure 14-1

7. Back the piece out, turn the piece part and repeat the sequence for the other end. See view "C" below.
8. Now that you have a pre-bend on both ends, it is time to roll the final diameter.
9. Back down the rear idler roll and start rolling the piece forward and reverse as shown in view "D".
10. Start raising the idler roll gradually and continue rolling the piece forward and reverse until you have reached the finished diameter.

Note: To achieve a cone configuration, adjust the idler roll on one end only.

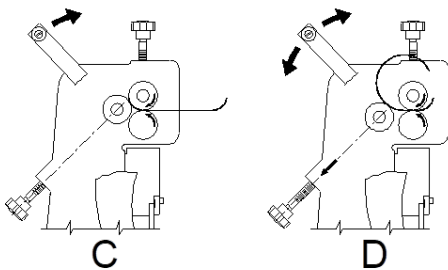

Figure 14-2

CAUTION

Have an assistant support the top roll when removing finished cylinders from the top roll. Failure to adequately support the top roll may result in the roll falling and causing personal injury.

11. Turn the notched shaft and slip the upper roll cylinder out to remove the work piece (fig 14-3).

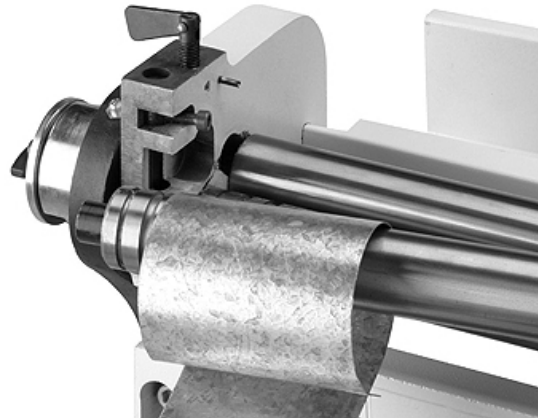

Figure 14-3

12. With the help of an assistant, lift the left end of the top roll, up and out, keeping the right end gears meshed as much as possible. The other person will slide the finished cylinder off. The roll is heavy, so DO NOT attempt this alone.

Note: Wire rolling is done the same way. Choose the same size groove on the upper and lower cylinders to match the wire gauge you are rolling.

14.4 Rolling Round Shapes

There are three wire or forming grooves located on the end of the upper and lower rolls (fig. 14-4). They can be used to form solid wire, rods, and small tubing.

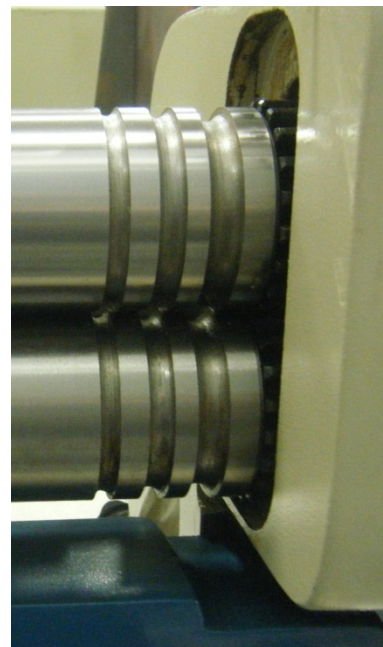

Figure 14-4

To make rings, follow the "Determining Length of Material" procedure to calculate the actual length. Then proceed with the rolling operation.

15.0 Material Selection

⚠ CAUTION

It must be determined by the customer that materials being processed through the machine are NOT potentially hazardous to operator or personnel working nearby.

When selecting materials keep these instructions in mind:

- Material must be clean and dry. (without oil)
- Material should have a smooth surface so it processes easily.
- Dimensional properties of material must be consistent and not exceed the machine capacity values.
- Chemical structure of material must be consistent.
- Buy certificated steel from the same vendor when possible.

16.0 Maintenance

⚠ WARNING

Maintenance should be performed on a regular basis by qualified personnel.

⚠ WARNING

Always follow proper safety precautions when working on or around any machinery.

Check for the following conditions and repair or replace when necessary:

- Check daily for any unsafe conditions and fix immediately.
- Check that all nuts and bolts are properly tightened.
- On a weekly basis clean the machine and the area around it.
- Lubricate gears, bushings, threaded components and sliding devices.
- Apply rust inhibitive lubricant to all non-painted surfaces.
- Loose mounting bolts.
- Chipped brake fingers.
- Dull or chipped shear blades.
- Inadequate lubrication.
- Any other condition that could hamper the safe operation of this machine.

16.1 Lubrication

Use a grease gun filled with general purpose grease on the crank arms as necessary on the installed grease fittings (fig 16-1).

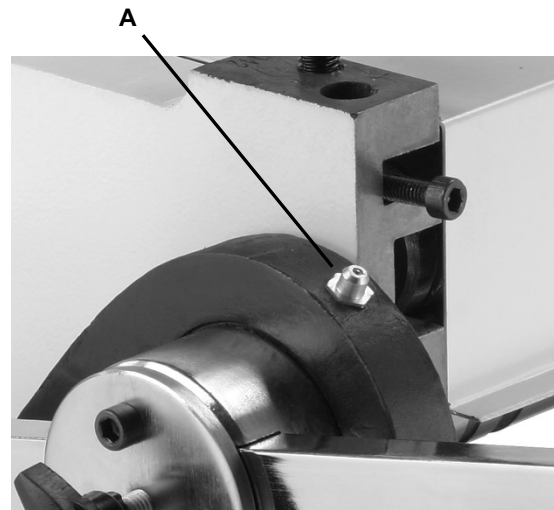

Figure 16-1

Lightly paint the slip roll gears with grease.

Wipe the unpainted parts of the sheet metal machine with a light coat of oil to prevent rust.

Grease Fitting

Note: Proper maintenance can increase the life expectancy of your machine.

17.0 Slip Roll Maintenance

17.1 Every (6) Months Remove and Lubricate the Roller Bushings

1. With the aid of an assistant carefully remove the top front roll. To do so, back off both top roll adjustment bolts, and rotate the roll release pin (left side of roll), 90°. Be careful not to damage the roll.
2. Remove both bushings from the ends of the roll.
3. With mineral spirits, wipe all old grease from the bushings, gears, roller end shafts, and machined pockets that the bushings rest on.
4. After the parts have dried, lubricate them sufficiently with multi-purpose grease.
5. Apply some 10W30 or equivalent oil into the bushings of the bottom front roll.
6. Lower the idler roll by turning the (2) idler adjustment bolts counterclockwise (**ccw**). This will give you access to apply oil to the bushings. (fig. 17-3)
7. Remove the idler adjustment bolts and clean the threads. Lubricate with oil and re-install. (fig. 17-2).

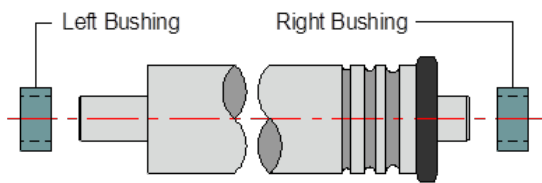

Top Front Roll
Figure 17-1

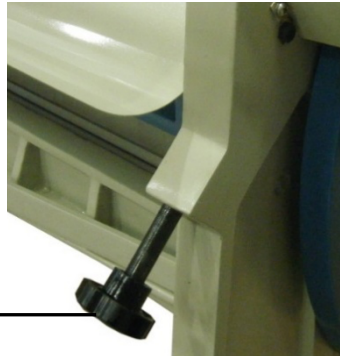

Idler Adjustment Bolts

Figure 17-2

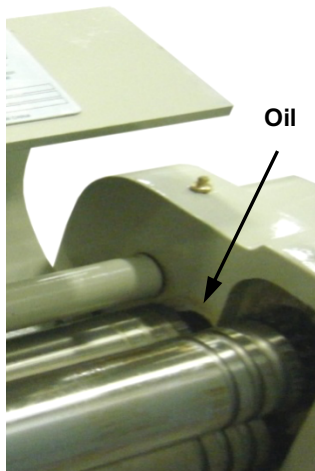

Oil

Figure 17-3

18.0 Brake Alignment

⚠ WARNING

The bending brake poses a pinching hazard. Make sure no body part or clothing is near the specific hazard. Failure to follow this warning could result in severed or crushed fingers.

On occasion, it may become necessary to realign the brake blades and the brake die. Follow the procedure below:

1. The first thing to do is clean and then deburr the brake blades and the V-groove of the brake die.
2. Make sure all brake blades are tight and seated properly.
3. Place a straight piece of .5" to .75" (12.7 to 19mm) diameter tubing (approx.) 12" (305mm)

long in the brake die "V"- groove as shown in (fig.18-1.)

4. Raise the blade die until the side of the pipe lightly contacts the brake blades.
5. From one end to the other, visually check for consistent contact between the pipe and the blades.
6. If you notice a gap at one end of the brake, loosen the (2) carriage lock cap screws at that end (fig. 18-2), and adjust the jack bolt until the brake blades just touch the pipe.
7. Tighten both cap screws and remove the pipe.
8. After cycling the brake a few times, recheck the alignment.

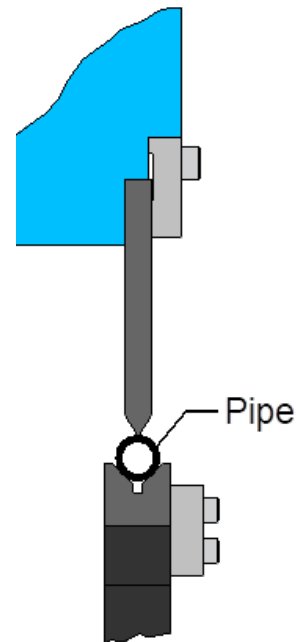
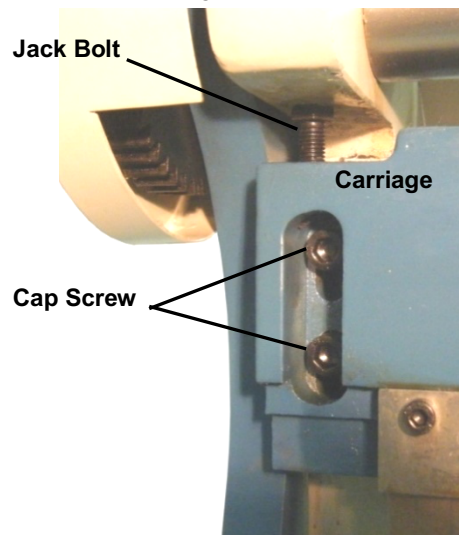

Figure 18-1



Jack Bolt

Carriage

Cap Screw

Figure 18-2

19.0 Replacing the Shear Blade

⚠ WARNING

The shear blade poses an amputation hazard. Make sure no body part or clothing is near the specific hazard. Failure to follow this warning could result in severed or crushed fingers.

The blades on the Baileigh Combination SBR each have four usable edges. If you have not already used all four cutting edges, you can rotate the blade to expose a sharp edge. After all edges have been used the blade can be reground or replaced.

Contact Baileigh Industrial for replacement blades.

19.1 Rotate or Replace the Blades

1. Remove the material hold down by unscrewing the bolts (#17) from the hold down bar (#63).
2. Raise the shearing blade assembly to the top of its stroke and secure either by blocking the frame or tying off the handlebar. MAKE SURE it is secure to avoid accidental shearing.
3. Remove the eight flathead screws holding on the upper blade (#20) and remove it from the movable blade. When handling the blade always wear leather gloves to protect your hands.
4. Either rotate the blade or replace it if all the sharp edges have been used. Replace the flat head screws and tighten securely.
5. To rotate or replace the lower blade you must work from the other side (rear) of the machine.
6. Remove the eight flathead screws holding on the lower blade and remove it from the shear apron (#71). When handling the blade always wear leather gloves to protect your hands.
7. Either rotate the blade or replace it if all the sharp edges have been used. Replace the flat head screws and tighten securely.
8. Install the hold down bar and adjust. See Shear Adjustment for procedure.
9. Adjust the shear blade. See Shear Adjustment for procedure.

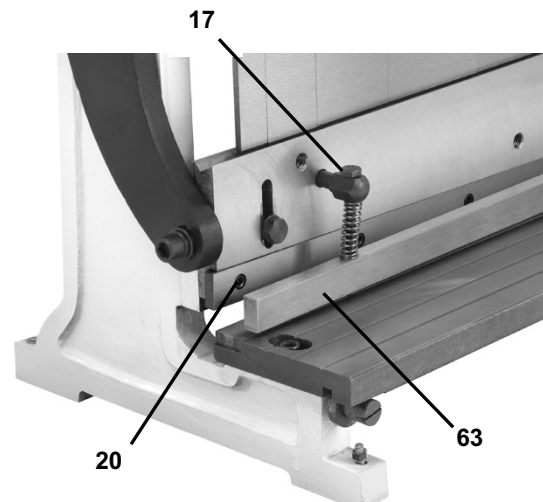

Figure 19-1

20.0 Troubleshooting

20.1 Shear Operation

Table 20-1

Fault	Probable Cause	Remedy
Can't shear material.	Improper blade gap distance, exceeding machine capacities.	Widen gap for thicker material.
Cuts are not square.	Blade gap unequal across length, Too much bow in blade, Inadequate hold down pressure.	Adjust blade gap to be equal across length, Adjust blade bow, Adjust hold down gap.
Poor quality of cuts, ripping, or tearing.	Dull blades, Poor blade gap set-up, Loose blade.	Replace or sharpen blades, adjust blade gap, Remove blade, clean mounting.

20.2 Brake Operation

Table 20-2

Fault	Probable Cause	Remedy
Heavy resistance during bends	Exceeding machine capacities.	Use materials within machine capabilities.
Bend radius is not consistent	Brake blades and die are not aligned.	Adjust brake alignment.
Brake blade points are chipping.	Brake blades and die are not aligned.	Adjust brake alignment.
Piece part shows scoring marks after bend.	Brake blades or die has scratches.	Polish out scratches.

20.3 Slip Roll Operation

Table 20-3

Fault	Probable Cause	Remedy
Slip Roll creates cones instead of cylinders.	Rolls are not parallel to each other.	Adjust the rear roll to be parallel to the top roll.
A noticeable crease forms in the piece part.	Excessive pressure applied to one spot.	Reduce the radius and make the bend in several passes.
Piece part is pitted.	Material sheet is dirty or roll is damaged.	Clean material, polish nicks in roller.

21.0 Replacement Parts

21.1.1 3-in-1 Combination Shear, Brake, Roll Assembly – Exploded View

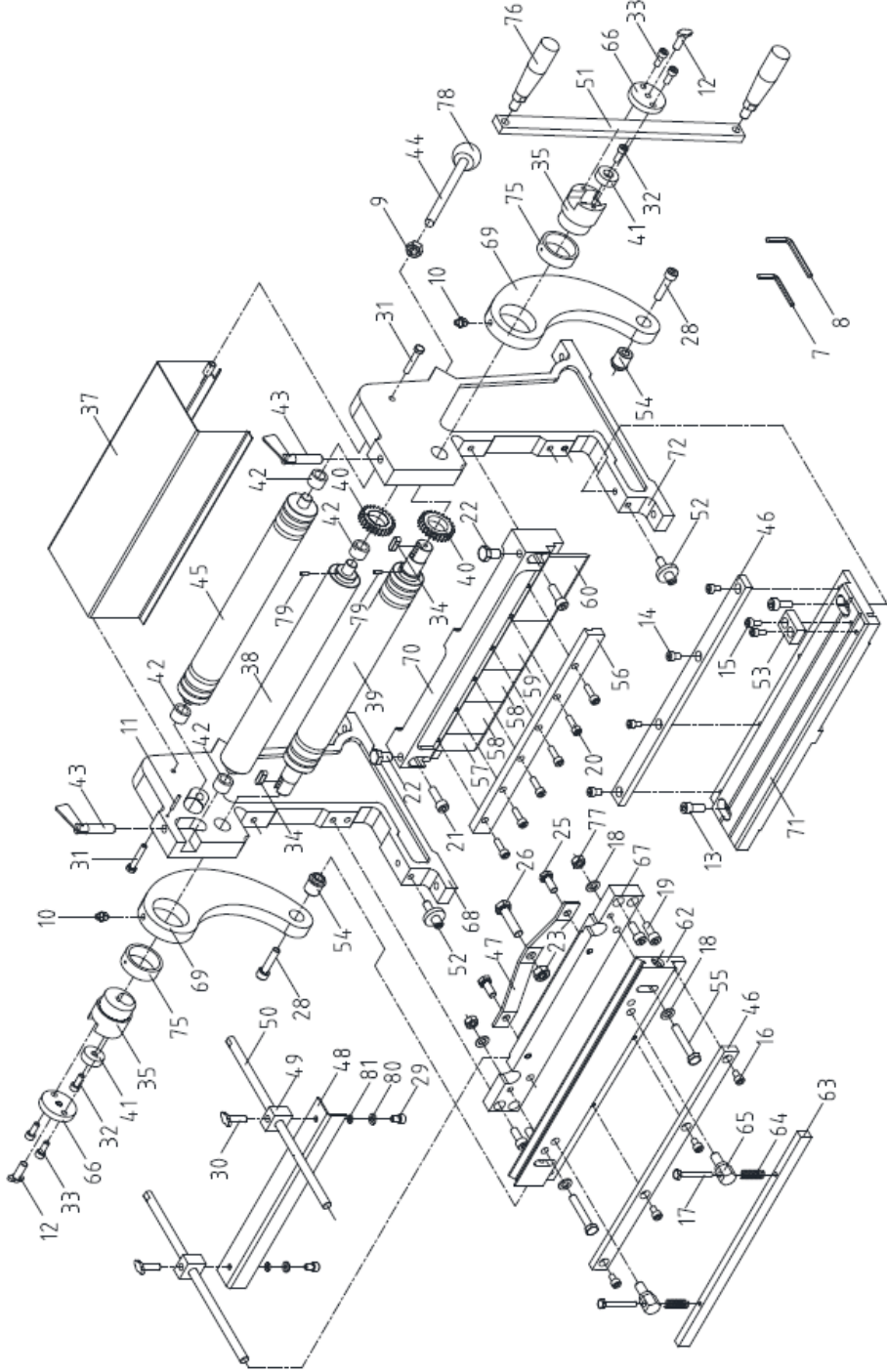

21.1.2 3-in-1 Combination Shear, Brake, Roll Assembly – Parts List

Index No	Part No	Description	Size	Qty
1	**	Model Number Label (not shown)		
2	**	Sheared Fingers Label (not shown)		
3	**	Read Manual Label (not shown)		
4	**	Safety Glasses Label (not shown)		
5	**	Nameplate-Small (not shown)		
6	**	Machine ID Label (not shown)		
7	BA9-1021541	Hex Wrench 6mm	5	1
8	BA9-1021545	Hex Wrench 5mm	6	1
9	**	Hex Nut	M10P1.5	2
10	**	Straight Grease Fittings	M8P1.0	2
11	BA9-1231323	Taper pins	3X22	2
12	BA1-10882	Knob		1
13	**	Socket Head Cap Screw	M8X20	2
14	**	Socket Head Cap Screw	M6X10	4
15	**	Socket Head Cap Screw	M6X10	2
16	**	Socket Head Cap Screw	M6X10	4
17	**	Hex Cap Screw	M6X45	2
18	**	Flat Washer	M8	2
19	**	Socket Head Cap Screw	M8X20	4
20	**	Socket Head Cap Screw	M6X20	6
21	**	Socket Head Cap Screw	M8X25	2
22	**	Hex Cap Screw	M10X16	2
23	**	Hex Nut	M10P1.5	1
25	**	Hex Cap Screw	M8X20	2
26	**	Hex Cap Screw	M10X40	1
28	**	Socket Head Cap Screw	M8X35	2
29	**	Socket Head Cap Screw	M6X10	2
30	BA1-10883	Knob		2
31	**	Hex Cap Screw	M6X35	2
32	**	Socket Head Cap Screw	M6X12	2
33	**	Socket Head Cap Screw	M6X16	4
34	**	Flat Key	6X20	2
35	**	Eccentric		2
37	**	Cover		1
38	**	Upper Roll Cylinder		1
39	**	Lower Roll Cylinder		1
40	BA9-1016546	Gear		2
41	**	Ring		2
42	BA9-1225204	Bushing		4
43	**	Adjustment Screw		2
44	**	Slip Roll Adjustment Knob		2
45	**	Rear Roll Cylinder		1
46	BA9-1021657	Blade Set		2
47	**	Blade Adjustment Bar		1
48	**	Work Stop		1
49	**	Block		2
50	**	Threaded Rod		2
	BA9-1020058	Stop Gauge		
51	BA9-1021486	Handle Arm		1
52	BA9-1227662	Blade Adjustment Bolt		2
53	**	Guide Block		1
54	**	Bushing		2
55	**	Hex Cap Screw	M8X50	2
56	**	Finger Plate		1
57	BA1-2402	Brake Finger 1"	1"	1
58	**	Brake Finger 2"	2"	2
59	**	Brake Finger 3"	3"	1
60	**	Brake Finger 4"	4"	1
62	**	Brake Die		1

Index No	Part No	Description	Size	Qty
63	BA9-1230314	Pressure Plate		1
64	BA9-1230315	Compression Spring		2
65	BA9-1230316	Press Plate Standoff		2
66	BA9-1224788	Cover		2
67	**	Cross Beam		1
68	**	Right Leg		1
69	BA9-1231112	Arm		2
70	BA9-1226136	Cross Beam		1
71	BA9-1226029	Work Table		1
72	BA9-1009222	Left Leg		1
73	BA9-1021546	Hex Wrench 3mm (not shown)		
74	BA9-1021547	Hex Wrench 4mm (not shown)		
75	**	Bushing		2
76	BA1-10884	Handle		2
77	**	Hex Nut	M8P1.25	2
78	BA1-10885	Ball		2
79	**	Roll Pin	3X10	2
80	**	Flat Washer	M6	2
81	**	Lock Washer	M6	2

** These parts are shown for reference only and are not available for order individually. Non-proprietary parts, such as fasteners, can usually be found at local hardware stores.

22.0 Warranty and Service

Thank you for your purchase of a machine from Baileigh Industrial. We hope that you find it productive and useful to you for a long time to come.

Inspection & Acceptance. Buyer shall inspect all Goods within ten (10) days after receipt thereof. Buyer's payment shall constitute final acceptance of the Goods and shall act as a waiver of the Buyer's rights to inspect or reject the Goods unless otherwise agreed. If Buyer rejects any merchandise, Buyer must first obtain a Returned Goods Authorization ("RGA") number before returning any Goods to Seller. Goods returned without an RGA will be refused. Seller will not be responsible for any freight costs, damages to Goods, or any other costs or liabilities pertaining to Goods returned without an RGA. Seller shall have the right to substitute a conforming tender. Buyer will be responsible for all freight costs to and from Buyer and repackaging costs, if any, if Buyer refuses to accept shipment. If Goods are returned in unsalable condition, Buyer shall be responsible for full value of the Goods. Buyer may not return any special-order Goods. Any Goods returned hereunder shall be subject to a restocking fee equal to 30% of the invoice price.

Specifications. Seller may, at its option, make changes in the designs, **specifications**, or components of the Goods to improve the safety of such Goods, or if in Seller's judgment, such changes will be beneficial to their operation or use. Buyer may not make any changes in the specifications for the Goods unless Seller approves of such changes in writing, in which event Seller may impose additional charges to implement such changes.

Limited Warranty. Seller warrants to the original end-user that the Goods manufactured or provided by Seller under this Agreement shall be free of defects in material or workmanship for a period of twelve (12) months from the date of purchase, provided that the Goods are installed, used, and maintained in accordance with any instruction manual or technical guidelines provided by the Seller or supplied with the Goods, if applicable. The original end-user must give written notice to Seller of any suspected defect in the Goods prior to the expiration of the warranty period. The original end-user must also obtain an RGA from Seller prior to returning any Goods to Seller for warranty service under this paragraph. Seller will not accept any responsibility for Goods returned without an RGA. The original end-user shall be responsible for all costs and expenses associated with returning the Goods to Seller for warranty service. In the event of a defect, Seller, at its sole option, shall repair or replace the defective Goods or refund to the original end-user the purchase price for such defective Goods. Goods are not eligible for replacement or return after a period of 10 days from date of receipt. The foregoing warranty is Seller's sole obligation, and the original end-user's exclusive remedy, with regard to any defective Goods. This limited warranty does not apply to: (a) die sets, tooling, and saw blades; (b) periodic or routine maintenance and setup, (c) repair or replacement of the Goods due to normal wear and tear, (d) defects or damage to the Goods resulting from misuse, abuse, neglect, or accidents, (f) defects or damage to the Goods resulting from improper or unauthorized alterations, modifications, or changes; and (f) any Goods that has not been installed and/or maintained in accordance with the instruction manual or technical guidelines provided by Seller.

EXCLUSION OF OTHER WARRANTIES. THE FOREGOING LIMITED WARRANTY IS IN LIEU OF ALL OTHER WARRANTIES, EXPRESS OR IMPLIED. ANY AND ALL OTHER EXPRESS, STATUTORY, OR IMPLIED WARRANTIES, INCLUDING BUT NOT LIMITED TO, ANY WARRANTY OF MERCHANTABILITY OR FITNESS FOR ANY PARTICULAR PURPOSE ARE EXPRESSLY DISCLAIMED. NO WARRANTY IS MADE WHICH EXTENDS BEYOND THAT WHICH IS EXPRESSLY CONTAINED HEREIN.

Limitation of Liability. IN NO EVENT SHALL SELLER BE LIABLE TO BUYER OR ANY OTHER PARTY FOR ANY INCIDENTAL, CONSEQUENTIAL OR SPECIAL DAMAGES (INCLUDING, WITHOUT LIMITATION, LOST PROFITS OR DOWN TIME) ARISING FROM OR IN MANNER CONNECTED WITH THE GOODS, ANY BREACH BY SELLER OR ITS AGENTS OF THIS AGREEMENT, OR ANY OTHER CAUSE WHATSOEVER, WHETHER BASED ON CONTRACT, TORT OR ANY OTHER THEORY OF LIABILITY. BUYER'S REMEDY WITH RESPECT TO ANY CLAIM ARISING UNDER THIS AGREEMENT IS STRICTLY LIMITED TO NO MORE THAN THE AMOUNT PAID BY THE BUYER FOR THE GOODS.

Force Majeure. Seller shall not be responsible for any delay in the delivery of, or failure to deliver, Goods due to causes beyond Seller's reasonable control including, without limitation, acts of God, acts of war or terrorism, enemy actions, hostilities, strikes, labor difficulties, embargoes, non-delivery or late delivery of materials, parts and equipment or transportation delays not caused by the fault of Seller, delays caused by civil authorities, governmental regulations or orders, fire, lightning, natural disasters or any other cause beyond Seller's reasonable control. In the event of any such delay, performance will be postponed by such length of time as may be reasonably necessary to compensate for the delay.

Installation. If Buyer purchases any Goods that require installation, Buyer shall, at its expense, make all arrangements and connections necessary to install and operate the Goods. Buyer shall install the Goods in accordance with any Seller instructions and shall indemnify Seller against any and all damages, demands, suits, causes of action, claims and expenses (including actual attorneys' fees and costs) arising directly or indirectly out of Buyer's failure to properly install the Goods.

Work By Others; Safety Devices. Unless agreed to in writing by Seller, Seller has no responsibility for labor or work performed by Buyer or others, of any nature, relating to design, manufacture, fabrication, use, installation, or provision of Goods. Buyer is solely responsible for furnishing and requiring its employees and customers to use all safety devices, guards and safe operating procedures required by law and/or as set forth in manuals and instruction sheets furnished by Seller. Buyer is responsible for consulting all operator manuals, ANSI or comparable safety standards, OSHA regulations and other sources of safety standards and regulations applicable to the use and operation of the Goods.

Remedies. Each of the rights and remedies of Seller under this Agreement is cumulative and in addition to any other or further remedies provided under this Agreement or at law or equity.

Attorney's Fees. In the event legal action is necessary to recover monies due from Buyer or to enforce any provision of this Agreement, Buyer shall be liable to Seller for all costs and expenses associated therewith, including Seller's actual attorney fees and costs.

Governing Law/Venue. This Agreement shall be construed and governed under the laws of the State of Wisconsin, without application of conflict of law principles. Each party agrees that all actions or proceedings arising out of or in connection with this Agreement shall be commenced, tried, and litigated only in the state courts sitting in Manitowoc County, Wisconsin or the U.S. Federal Court for the Eastern District of Wisconsin. Each party waives any right it may have to assert the doctrine of "forum non conveniens" or to object to venue to the extent that any proceeding is brought in accordance with this section. Each party consents to and waives any objection to the exercise of personal jurisdiction over it by courts described in this section. Each party waives to the fullest extent permitted by applicable law the right to a trial by jury.

Summary of Return Policy:

- 10 Day acceptance period from date of delivery. Damage claims and order discrepancies will not be accepted after this time.
- You must obtain a Baileigh Industrial issued RGA number PRIOR to returning any materials.
- Returned materials must be received at Baileigh Industrial in new condition and in original packaging.
- Altered items are not eligible for return.
- Buyer is responsible for all shipping charges.
- A 30% re-stocking fee applies to all returns.

Baileigh Industrial makes every effort to ensure that our posted specifications, images, pricing, and product availability are as correct and timely as possible. We apologize for any discrepancies that may occur. Baileigh Industrial reserves the right to make any and all changes deemed necessary in the course of business including but not limited to pricing, product specifications, quantities, and product availability.

For Customer Service & Technical Support:

Please contact one of our knowledgeable Sales and Service team members at:
(920) 684-4990 or e-mail us at Baileigh-Service@jpwindustries.com



BAILEIGH INDUSTRIAL

1625 DUFEK DRIVE MANITOWOC, WI 54220

PHONE: 920.684.4990 FAX: 920.684.3944

www.baileigh.com