



# OPERATOR'S MANUAL

Metal Working



## HYDRAULIC SHEAR MODEL: SH-12010

Baileigh Industrial Holdings LLC  
P.O. Box 531  
Manitowoc, WI 54221-0531  
Phone: 920.684.4990  
Fax: 920.684.3944  
[sales@baileigh.com](mailto:sales@baileigh.com)

REPRODUCTION OF THIS MANUAL IN ANY FORM WITHOUT WRITTEN APPROVAL OF BAILEIGH INDUSTRIAL HOLDINGS LLC IS PROHIBITED. Baileigh Industrial Holdings LLC, Inc. does not assume and hereby disclaims any liability for any damage or loss caused by an omission or error in this Operator's Manual, resulting from accident, negligence, or other occurrence.

Rev. 11/2020



## Table of Contents

THANK YOU & WARRANTY .....	1
INTRODUCTION.....	3
GENERAL NOTES.....	3
SAFETY INSTRUCTIONS .....	4
SAFETY PRECAUTIONS .....	7
Dear Valued Customer:.....	7
Electrical Enclosure Disconnect Switch.....	9
TECHNICAL SPECIFICATIONS .....	10
TECHNICAL SUPPORT .....	10
UNPACKING AND CHECKING CONTENTS.....	11
TRANSPORTING AND LIFTING .....	14
INSTALLATION.....	15
Anchoring the Machine.....	16
OVERALL DIMENSIONS.....	17
GETTING TO KNOW YOUR MACHINE .....	18
Electrical Enclosure Switch and Button Functions.....	21
Manual Back gauge.....	22
Material Support Arm.....	23
ELECTRICAL.....	24
BLADE CLEARANCE .....	26
SHEARING STRENGTH OF MATERIALS .....	27
SHEARING OPERATION .....	28
Shearing Tips .....	28
SHEAR OPERATING PROCEDURE.....	29
Start Machine Power .....	29
Start Hydraulic Pump Motor .....	29
Single Mode.....	30
Auto Mode .....	31
Turning Off Machine Power.....	32
LUBRICATION AND MAINTENANCE .....	33
Lubrication Locations.....	34
Hydraulic Oil .....	35
Oil Change and Disposal.....	35
Filter and Oil Change.....	36
REPLACING THE SHEAR BLADES.....	37
To Rotate or Replace the Top Blade .....	37
To Rotate or Replace the Bottom Blade .....	38
BLADE CARE .....	39
RAM WAYS ADJUSTMENT.....	39
FINGER GUARD.....	40
MATERIAL SELECTION.....	40
MANIFOLD BLOCK .....	41
Hydraulic Parts List.....	41



HYDRAULIC SCHEMATIC .....	42
PARTS IDENTIFICATION DRAWING A .....	43
Parts List .....	44
PARTS IDENTIFICATION DRAWING C .....	46
Back Gauge Parts List - C .....	48
ELECTRICAL SCHEMATIC - 1 .....	49
ELECTRICAL SCHEMATIC - 2 .....	50
ELECTRICAL PARTS LIST .....	51
ELECTRICAL ENCLOSURE .....	52
TROUBLESHOOTING .....	53



## THANK YOU & WARRANTY

Thank you for your purchase of a machine from Baileigh Industrial Holdings LLC. We hope that you find it productive and useful to you for a long time to come.

**Inspection & Acceptance.** Buyer shall inspect all Goods within ten (10) days after receipt thereof. Buyer's payment shall constitute final acceptance of the Goods and shall act as a waiver of the Buyer's rights to inspect or reject the goods unless otherwise agreed. If Buyer rejects any merchandise, Buyer must first obtain a Returned Goods Authorization ("RGA") number before returning any goods to Seller. Goods returned without an RGA will be refused. Seller will not be responsible for any freight costs, damages to goods, or any other costs or liabilities pertaining to goods returned without a RGA. Seller shall have the right to substitute a conforming tender. Buyer will be responsible for all freight costs to and from Buyer and repackaging costs, if any, if Buyer refuses to accept shipment. If Goods are returned in unsalable condition, Buyer shall be responsible for full value of the Goods. Buyer may not return any special-order Goods. Any Goods returned hereunder shall be subject to a restocking fee equal to 30% of the invoice price.

**Specifications.** Seller may, at its option, make changes in the designs, specifications or components of the Goods to improve the safety of such Goods, or if in Seller's judgment, such changes will be beneficial to their operation or use. Buyer may not make any changes in the specifications for the Goods unless Seller approves of such changes in writing, in which event Seller may impose additional charges to implement such changes.

**Limited Warranty.** Seller warrants to the original end-user that the Goods manufactured or provided by Seller under this Agreement shall be free of defects in material or workmanship for a period of twelve (12) months from the date of purchase, provided that the Goods are installed, used, and maintained in accordance with any instruction manual or technical guidelines provided by the Seller or supplied with the Goods, if applicable. The original end-user must give written notice to Seller of any suspected defect in the Goods prior to the expiration of the warranty period. The original end-user must also obtain a RGA from Seller prior to returning any Goods to Seller for warranty service under this paragraph. Seller will not accept any responsibility for Goods returned without a RGA. The original end-user shall be responsible for all costs and expenses associated with returning the Goods to Seller for warranty service. In the event of a defect, Seller, at its sole option, shall repair or replace the defective Goods or refund to the original end-user the purchase price for such defective Goods. Goods are not eligible for replacement or return after a period of 10 days from date of receipt. The foregoing warranty is Seller's sole obligation, and the original end-user's exclusive remedy, with regard to any defective Goods. This limited warranty does not apply to: (a) die sets, tooling, and saw blades; (b) periodic or routine maintenance and setup, (c) repair or replacement of the Goods due to normal wear and tear, (d) defects or damage to the Goods resulting from misuse, abuse, neglect, or accidents, (e) defects or damage to the Goods resulting from improper or unauthorized alterations, modifications, or changes; and (f) any Goods that has not been installed and/or maintained in accordance with the instruction manual or technical guidelines provided by Seller.

**EXCLUSION OF OTHER WARRANTIES.** THE FOREGOING LIMITED WARRANTY IS IN LIEU OF ALL OTHER WARRANTIES, EXPRESS OR IMPLIED. ANY AND ALL OTHER EXPRESS, STATUTORY OR IMPLIED WARRANTIES, INCLUDING BUT NOT LIMITED TO, ANY WARRANTY OF MERCHANTABILITY OR FITNESS FOR ANY PARTICULAR PURPOSE ARE EXPRESSLY DISCLAIMED. NO WARRANTY IS MADE WHICH EXTENDS BEYOND THAT WHICH IS EXPRESSLY CONTAINED HEREIN.

**Limitation of Liability.** IN NO EVENT SHALL SELLER BE LIABLE TO BUYER OR ANY OTHER PARTY FOR ANY INCIDENTAL, CONSEQUENTIAL OR SPECIAL DAMAGES (INCLUDING, WITHOUT LIMITATION, LOST PROFITS OR DOWN TIME) ARISING FROM OR IN MANNER CONNECTED WITH THE GOODS, ANY BREACH BY SELLER OR ITS AGENTS OF THIS AGREEMENT, OR ANY OTHER CAUSE WHATSOEVER, WHETHER BASED ON CONTRACT, TORT OR ANY OTHER THEORY OF LIABILITY. BUYER'S REMEDY WITH RESPECT TO ANY CLAIM ARISING UNDER THIS AGREEMENT IS STRICTLY LIMITED TO NO MORE THAN THE AMOUNT PAID BY THE BUYER FOR THE GOODS.



**Force Majeure.** Seller shall not be responsible for any delay in the delivery of, or failure to deliver, Goods due to causes beyond Seller's reasonable control including, without limitation, acts of God, acts of war or terrorism, enemy actions, hostilities, strikes, labor difficulties, embargoes, non-delivery or late delivery of materials, parts and equipment or transportation delays not caused by the fault of Seller, delays caused by civil authorities, governmental regulations or orders, fire, lightening, natural disasters or any other cause beyond Seller's reasonable control. In the event of any such delay, performance will be postponed by such length of time as may be reasonably necessary to compensate for the delay.

**Installation.** If Buyer purchases any Goods that require installation, Buyer shall, at its expense, make all arrangements and connections necessary to install and operate the Goods. Buyer shall install the Goods in accordance with any Seller instructions and shall indemnify Seller against any and all damages, demands, suits, causes of action, claims and expenses (including actual attorneys' fees and costs) arising directly or indirectly out of Buyer's failure to properly install the Goods.

**Work By Others; Safety Devices.** Unless agreed to in writing by Seller, Seller has no responsibility for labor or work performed by Buyer or others, of any nature, relating to design, manufacture, fabrication, use, installation or provision of Goods. Buyer is solely responsible for furnishing and requiring its employees and customers to use all safety devices, guards and safe operating procedures required by law and/or as set forth in manuals and instruction sheets furnished by Seller. Buyer is responsible for consulting all operator manuals, ANSI or comparable safety standards, OSHA regulations and other sources of safety standards and regulations applicable to the use and operation of the Goods.

**Remedies.** Each of the rights and remedies of Seller under this Agreement is cumulative and in addition to any other or further remedies provided under this Agreement or at law or equity.

**Attorney's Fees.** In the event legal action is necessary to recover monies due from Buyer or to enforce any provision of this Agreement, Buyer shall be liable to Seller for all costs and expenses associated therewith, including Seller's actual attorney fees and costs.

**Governing Law/Venue.** This Agreement shall be construed and governed under the laws of the State of Wisconsin, without application of conflict of law principles. Each party agrees that all actions or proceedings arising out of or in connection with this Agreement shall be commenced, tried, and litigated only in the state courts sitting in Manitowoc County, Wisconsin or the U.S. Federal Court for the Eastern District of Wisconsin. Each party waives any right it may have to assert the doctrine of "forum non conveniens" or to object to venue to the extent that any proceeding is brought in accordance with this section. Each party consents to and waives any objection to the exercise of personal jurisdiction over it by courts described in this section. Each party waives to the fullest extent permitted by applicable law the right to a trial by jury.

**Summary of Return Policy.**

- 10 Day acceptance period from date of delivery. Damage claims and order discrepancies will not be accepted after this time.
- You must obtain a Baileigh issued RGA number PRIOR to returning any materials.
- Returned materials must be received at Baileigh in new condition and in original packaging.
- Altered items are not eligible for return.
- Buyer is responsible for all shipping charges.
- A 30% re-stocking fee applies to all returns.

Baileigh Industrial Holdings LLC makes every effort to ensure that our posted specifications, images, pricing and product availability are as correct and timely as possible. We apologize for any discrepancies that may occur. Baileigh Industrial Holdings LLC reserves the right to make any and all changes deemed necessary in the course of business including but not limited to pricing, product specifications, quantities, and product availability.

**For Customer Service & Technical Support:**

Please contact one of our knowledgeable Sales and Service team members at:  
(920) 684-4990 or e-mail us at [sales@baileigh.com](mailto:sales@baileigh.com)



## **INTRODUCTION**

*The quality and reliability of the components assembled on a Baileigh Industrial Holdings LLC machine guarantee near perfect functioning, free from problems, even under the most demanding working conditions. However, if a situation arises, refer to the manual first. If a solution cannot be found, contact the distributor where you purchased our product. Make sure you have the serial number and production year of the machine (stamped on the nameplate). For replacement parts refer to the assembly numbers on the parts list drawings.*

*Our technical staff will do their best to help you get your machine back in working order.*

### **In this manual you will find: (when applicable)**

- Safety procedures
- Correct installation guidelines
- Description of the functional parts of the machine
- Capacity charts
- Setup and start-up instructions
- Machine operation
- Scheduled maintenance
- Parts lists

## **GENERAL NOTES**

After receiving your equipment remove the protective container. Do a complete visual inspection, and if damage is noted, **photograph it for insurance claims** and contact your carrier at once, requesting inspection. Also contact Baileigh Industrial Holdings LLC and inform them of the unexpected occurrence. Temporarily suspend installation.

Take necessary precautions while loading / unloading or moving the machine to avoid any injuries.

Your machine is designed and manufactured to work smoothly and efficiently. Following proper maintenance instructions will help ensure this. Try and use original spare parts, whenever possible, and most importantly; **DO NOT** overload the machine or make any modifications.



**Note:** This symbol refers to useful information throughout the manual.



## IMPORTANT

### PLEASE READ THIS OPERATORS MANUAL CAREFULLY

It contains important safety information, instructions, and necessary operating procedures. The continual observance of these procedures will help increase your production and extend the life of the equipment.

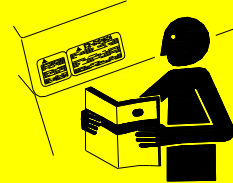

## SAFETY INSTRUCTIONS

### LEARN TO RECOGNIZE SAFETY INFORMATION

This is the safety alert symbol. When you see this symbol on your machine or in this manual, **BE ALERT TO THE POTENTIAL FOR PERSONAL INJURY!**



Follow recommended precautions and safe operating practices.

### UNDERSTAND SIGNAL WORDS

A signal word – **DANGER**, **WARNING**, or **CAUTION** – is used with the safety alert symbol. **NOTICE**, which is not related to personal injury, is used without a symbol.

**DANGER:** Indicates a hazardous situation which, if not avoided, will result in death or serious injury.

**WARNING:** Indicates a hazardous situation which, if not avoided, could result in death or serious injury.

**CAUTION:** Indicates a hazardous situation which, if not avoided, could result in minor or moderate injury.

**NOTICE:** Indicates a situation which, if not avoided, could result in property damage.

**DANGER**

**WARNING**

**CAUTION**

**NOTICE**



**SAVE THESE INSTRUCTIONS.**  
**Refer to them often and use them to instruct others.**



**PROTECT EYES**

Wear safety glasses or suitable eye protection when working on or around machinery.

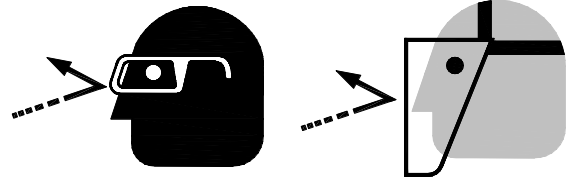

**PROTECT AGAINST NOISE**

Prolonged exposure to loud noise can cause impairment or loss of hearing. Wear suitable hearing protective devices such as ear muffs or earplugs to protect against objectionable or uncomfortable loud noises.

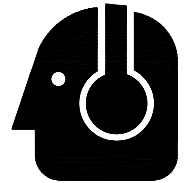

**HYDRAULIC HOSE FAILURE**

Exercise **CAUTION** around hydraulic hoses in case of a hose or fitting failure.

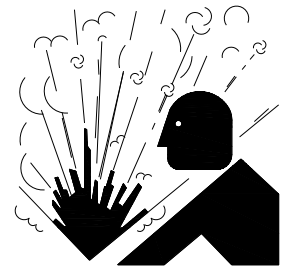

**BEWARE OF SHEAR HAZARD**

Blade is sharp. Keep hands and fingers clear from under the blade. Placing hands or fingers near blade will result in cuts and possibly loss of fingers or limbs if placed in machine. **NEVER** place your hand or any part of your body in this machine.

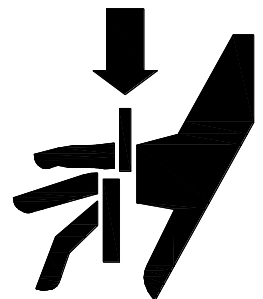

**HIGH VOLTAGE**

**USE CAUTION IN HIGH VOLTAGE AREAS. DO NOT** assume the power to be off.  
**FOLLOW PROPER LOCKOUT PROCEDURES.**

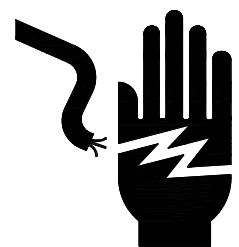



### **EMERGENCY STOP BUTTON**

In the event of incorrect operation or dangerous conditions, the machine can be stopped immediately by pressing the **E-STOP** button. Twist the emergency stop button clockwise (cw) to reset. Note: Resetting the E-Stop will not start the machine.



### **CALIFORNIA PROPOSITION 65**

WARNING: Cancer and Reproductive Harm.  
[www.P65Warnings.ca.gov](http://www.P65Warnings.ca.gov)





## **SAFETY PRECAUTIONS**



Metal working can be dangerous if safe and proper operating procedures are not followed. As with all machinery, there are certain hazards involved with the operation of the product. Using the machine with respect and caution will considerably lessen the possibility of personal injury. However, if normal safety precautions are overlooked or ignored, personal injury to the operator may result.

Safety equipment such as guards, hold-downs, safety glasses, dust masks and hearing protection can reduce your potential for injury. But even the best guard will not make up for poor judgment, carelessness or inattention. **Always use common sense** and exercise **caution** in the workshop. If a procedure feels dangerous, don't try it.

**REMEMBER: Your personal safety is your responsibility.**



**WARNING: FAILURE TO FOLLOW THESE RULES MAY RESULT IN SERIOUS PERSONAL INJURY**

### **Dear Valued Customer:**

- All Baileigh machines should be used only for their intended use.
- Baileigh does not recommend or endorse making any modifications or alterations to a Baileigh machine. Modifications or alterations to a machine may pose a substantial risk of injury to the operator or others and may do substantial damage to the machine.
- Any modifications or alterations to a Baileigh machine will invalidate the machine's warranty.

### **PLEASE ENJOY YOUR BAILEIGH MACHINE! ....PLEASE ENJOY IT SAFELY!**

1. **FOR YOUR OWN SAFETY, READ INSTRUCTION MANUAL BEFORE OPERATING THE MACHINE.** Learn the machine's application and limitations as well as the specific hazards.
2. **Only trained and qualified personnel can operate this machine.**
3. **Make sure guards are in place and in proper working order before operating machinery.**
4. **Remove any adjusting tools.** Before operating the machine, make sure any adjusting tools have been removed.
5. **Keep work area clean.** Cluttered areas invite injuries.
6. **Overloading machine.** By overloading the machine, you may cause injury from flying parts. **DO NOT** exceed the specified machine capacities.
7. **Dressing material edges.** Always chamfer and deburr all sharp edges.



8. **Do not force tool.** Your machine will do a better and safer job if used as intended. **DO NOT** use inappropriate attachments in an attempt to exceed the machine's rated capacity.
9. **Use the right tool for the job. DO NOT** attempt to force a small tool or attachment to do the work of a large industrial tool. **DO NOT** use a tool for a purpose for which it was not intended.
10. **Dress appropriately. DO NOT** wear loose fitting clothing or jewelry as they can be caught in moving machine parts. Protective clothing and steel toe shoes are recommended when using machinery. Wear a restrictive hair covering to contain long hair.
11. **Use eye protection.** Always wear ISO approved protective eye wear when operating machinery. Wear a full-face shield if you are producing metal filings. Eye wear shall be impact resistant, protective safety glasses with side shields which comply with ANSI Z87.1 specification. Use of eye wear which does not comply with ANSI Z87.1 specification could result in severe injury from breakage of eye protection.
12. **Do not overreach.** Maintain proper footing and balance at all times. **DO NOT** reach over or across a running machine.
13. **Stay alert.** Watch what you are doing and use common sense. **DO NOT** operate any tool or machine when you are tired.
14. **Check for damaged parts.** Before using any tool or machine, carefully check any part that appears damaged. Check for alignment and binding of moving parts that may affect proper machine operation.
15. **Observe work area conditions. DO NOT** use machines or power tools in damp or wet locations. Do not expose to rain. Keep work area well lighted. **DO NOT** use electrically powered tools in the presence of flammable gases or liquids.
16. **Blade adjustments and maintenance.** Always keep blades sharp and properly adjusted for optimum performance.
17. **Keep children away.** Children must never be allowed in the work area. **DO NOT** let them handle machines, tools, or extension cords.
18. Keep visitors a safe distance from the work area.
19. **Store idle equipment.** When not in use, tools must be stored in a dry location to inhibit rust. Always lock up tools and keep them out of reach of children.
20. **DO NOT operate machine if under the influence of alcohol or drugs.** Read warning labels on prescriptions. If there is any doubt, **DO NOT** operate the machine.
21. **Turn off** power before checking, cleaning, or replacing any parts.
22. Be sure **all** equipment is properly installed and grounded according to national, state, and local codes.
23. Inspect power and control cables periodically. Replace if damaged or bare wires are exposed. **Bare wiring can kill!** **DO NOT** touch live electrical components or parts.
24. **DO NOT** bypass or defeat any safety interlock systems.



## Electrical Enclosure Disconnect Switch

The main disconnect switch (**B**) turns power on to the machine when in the “**ON**” position. If the door handle is turned while the switch is “**ON**”, a safety catch will prevent the door from opening.

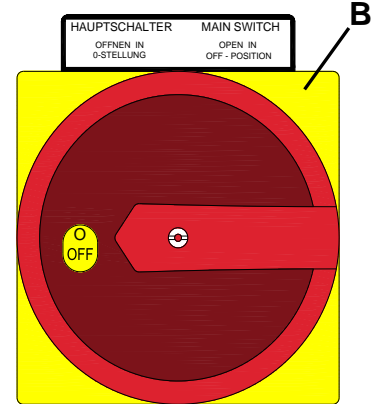

**WARNING:** Before opening the door to work on electrical circuits, turn the main disconnect switch “**OFF**”. Also turn off and Lock Out the electrical supply source to this machine. FAILURE TO FOLLOW THESE INSTRUCTIONS MAY RESULT IN FATAL OR SERIOUS INJURY.

## Hazard Signs

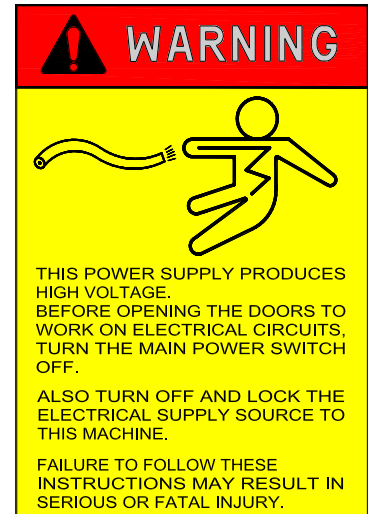
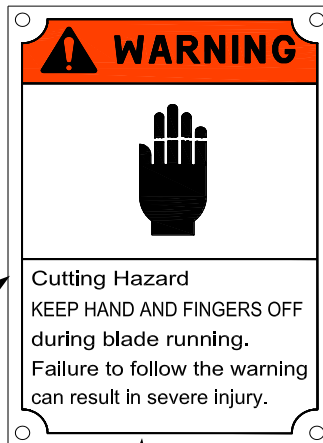



## TECHNICAL SPECIFICATIONS

Maximum Shear Length	120" (3048mm)
Maximum Material Thickness	10ga. (3.5mm) mild steel* 13ga. (2.3mm) stainless steel**
Minimum Material Thickness	24ga. (0.607mm)
Strokes/Minute	20
Front Material Support (at full extension)	21.625" (550mm)
Back Gauge Length	24" (610mm)
Blade Angle	2°
Motor	7.5Hp (5.59Kw) 220V / 3Ph / 60Hz / 27.5A
Power Requirements	220V / 3Ph / 60Hz
Hydraulic Oil Capacity	20gal (75L)
Shipping Dimensions (L x W x H)	145" x 45" x 60" (3683 x 1143 x 1524mm)
Shipping Weight	6600 lbs. (2994 kg)
Based on a material tensile strength of *64000 PSI – mild steel **100000 PSI – stainless steel	

## TECHNICAL SUPPORT

Our technical support department can be reached at 920.684.4990 and asking for the support desk for purchased machines. Tech Support handles questions on machine setup, schematics, warranty issues, and individual parts needs: (other than die sets and blades).

For specific application needs or future machine purchases contact the Sales Department at: [sales@baileigh.com](mailto:sales@baileigh.com), Phone: 920.684.4990, or Fax: 920.684.3944.



**Note:** *The photos and illustrations used in this manual are representative only and may not depict the actual color, labeling or accessories and may be intended to illustrate technique only.*



**Note:** *The specifications and dimensions presented here are subject to change without prior notice due to improvements of our products.*



## UNPACKING AND CHECKING CONTENTS

Your Baileigh machine is shipped complete. Separate all parts from the packing material and check each item carefully. Make certain all items are accounted for before discarding any packing material.

**⚠ WARNING: SUFFOCATION HAZARD!** Immediately discard any plastic bags and packing materials to eliminate choking and suffocation hazards to children and animals.  
If any parts are missing, **DO NOT** place the machine into service until the missing parts are obtained and installed correctly.

### Cleaning

**⚠ WARNING: DO NOT USE** gasoline or other petroleum products to clean the machine. They have low flash points and can explode or cause fire.

**⚠ CAUTION:** When using cleaning solvents work in a well-ventilated area. Many cleaning solvents are toxic if inhaled.

Your machine may be shipped with a rustproof waxy coating and/or grease on the exposed unpainted metal surfaces. Fully and completely remove this protective coating using a degreaser or solvent cleaner. Moving items will need to be moved along their travel path to allow for cleaning the entire surface. For a more thorough cleaning, some parts will occasionally have to be removed. **DO NOT USE** acetone or brake cleaner as they may damage painted surfaces.

Follow manufacturer's label instructions when using any type of cleaning product. After cleaning, wipe unpainted metal surfaces with a light coating of quality oil or grease for protection.



**Important:** This waxy coating is **NOT** a lubricant and will cause the machine to stick and lose performance as the coating continues to dry.





**Contents of Tool Box:**

Lever Type Grease Gun	1 pc
300mm Adjustable Wrench	1 pc
6 x 100mm Phillips Screwdriver	1 pc
Touchup Paint	3 cans
10 pc Hex Wrenches (1.5 - 2.0 - 2.5 - 3 - 4 - 5 - 5.5 - 6 - 8 - 10mm)	1 set



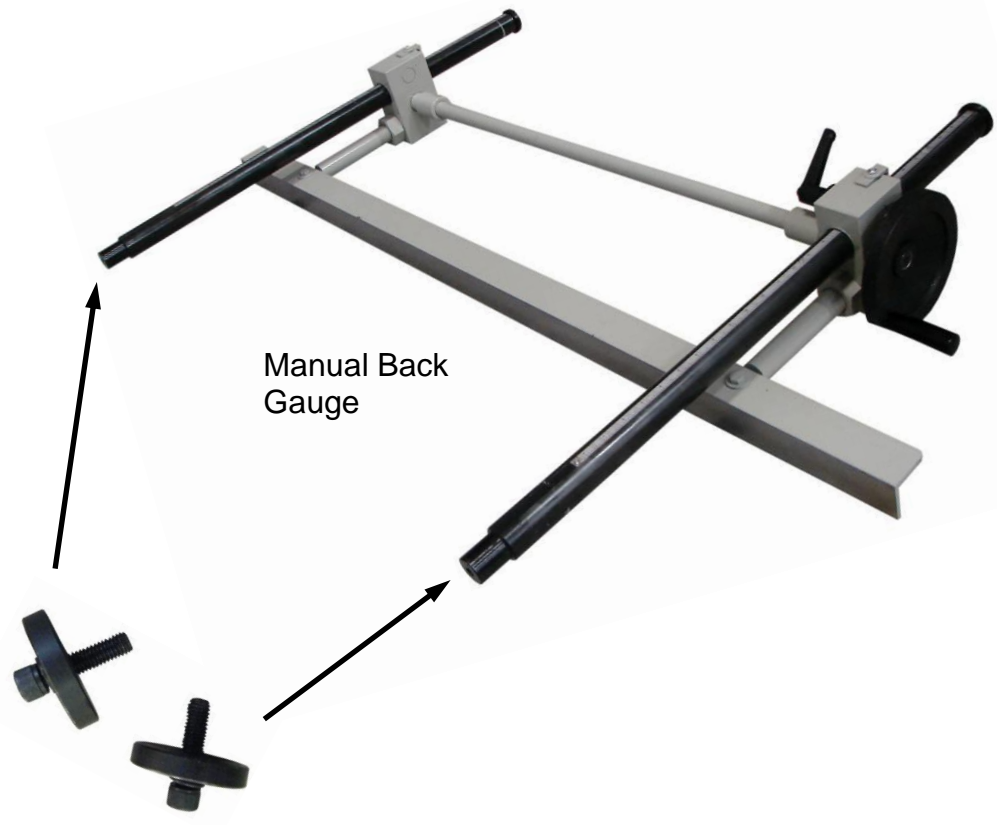

Manual Back Gauge

Back Gauge Washers and bolts



Pedestal with Foot Pedal and Emergency Stop Switch



## TRANSPORTING AND LIFTING

**⚠ CAUTION:** Lifting and carrying operations should be carried out by skilled workers, such as a truck operator, crane operator, etc. If a crane is used to lift the machine, attach the lifting chain carefully, making sure the machine is well balanced. Choose a location that will keep the machine free from vibration and dust from other machinery. Keep in mind that having a large clearance area around the machine is important for safe and efficient working conditions.

### Follow these guidelines when lifting:

- Always lift and carry the machine with the lifting holes provided at the top of the machine.
- Use lift equipment such as straps, chains, capable of lifting 1.5 to 2 times the weight of the machine.
- Take proper precautions for handling and lifting.
- Check if the load is properly balanced by lifting it an inch or two.
- Lift the machine, avoiding sudden accelerations or quick changes of direction.
- Locate the machine where it is to be installed, then lower slowly until it touches the floor.



**Note:** The photos and illustrations used in this manual are representative only and may not depict the actual color, labeling or accessories and may be intended to illustrate technique only.



- The lift truck must be able to lift at least 1.5 – 2 times the machines gross weight.
- Make sure the machine is balanced. While transporting, avoid rough or jerky motion, and maintain a safe clearance zone around the transport area.
- Use a fork lift with sufficient lifting capacity and forks that are long enough to reach the complete width of the machine.
- Remove the securing bolts that attach the machine to the pallet.
- Approaching the machine from the side, lift the machine on the frame taking care that there are no cables or pipes in the area of the forks.
- Move the machine to the required position and lower gently to the floor.
- Level the machine so that all the supporting feet are taking the weight of the machine and no rocking is taking place.

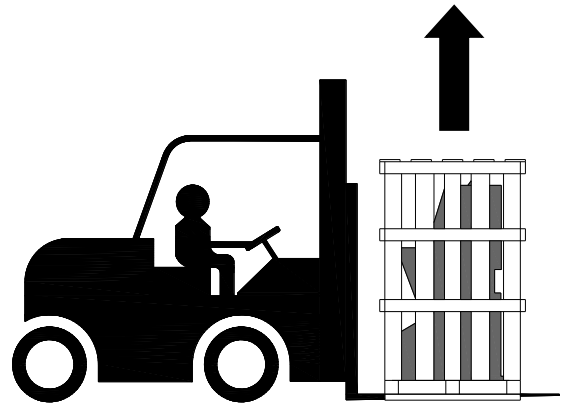

## **INSTALLATION**

### **IMPORTANT:**

Consider the following when looking for a suitable location to place the machine:

- Overall weight of the machine.
- Weight of material being processed.
- Sizes of material to be processed through the machine.
- Space needed for auxiliary stands, work tables, or other machinery.
- Clearance from walls and other obstacles.
- Maintain an adequate working area around the machine for safety.
- Have the work area well illuminated with proper lighting.
- Keep the floor free of oil and make sure it is not slippery.
- Remove scrap and waste materials regularly, and make sure the work area is free from obstructing objects.
- If long lengths of material are to be fed into the machine, make sure that they will not extend into any aisles.



- **LEVELING:** The machine should be sited on a level, concrete floor. Provisions for securing it should be in position prior to placing the machine. The accuracy of any machine depends on the precise placement of it to the mounting surface.
- **FLOOR:** This machine distributes a large amount of weight over a small area. Make certain that the floor is capable of supporting the weight of the machine, work stock, and the operator. The floor should also be a level surface. If the unit wobbles or rocks once in place, be sure to eliminate by using shims.
- **WORKING CLEARANCES:** Take into consideration the size of the material to be processed. Make sure that you allow enough space for you to operate the machine freely.
- **POWER SUPPLY PLACEMENT:** The power supply should be located close enough to the machine so that the power cord is not in an area where it would cause a tripping hazard. Be sure to observe all electrical codes if installing new circuits and/or outlets.

### Anchoring the Machine

- Once positioned, anchor the machine to the floor, as shown in the diagram. Use bolts and expansion plugs or sunken tie rods that connect through and are sized for the holes in the base of the stand.
- This machine requires a solid floor such as concrete at a minimum of 4" (102mm) thick. 6" (153mm) minimum is preferred.

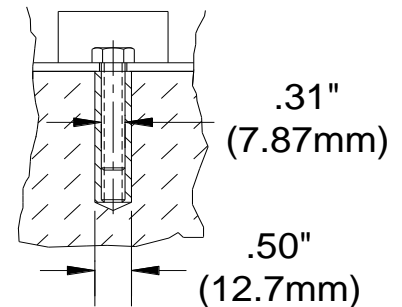

### Tank Filling

The hydraulic oil is the primary medium for transmitting pressure and also must lubricate the running parts of the pump.

After installation of the machine and before machine startup, bring the oil level up to 90% of capacity. Refer to any labels or marking affixed to the outside of the machine, if none exist, use SHELL BRAND #46 or #68 hydraulic oil or an equivalent with similar specifications. (Based upon location temperature and availability.)

Verify that any cylinder rams are in the retracted position to prevent overfilling of the tank. Recheck the oil level after the first few hours of operation and again after the first full week of operation.

**A shortage of hydraulic oil can cause hydraulic system breakdown and damage to major mechanical parts due to overheating.**



## OVERALL DIMENSIONS

SH-12010  
Crate: 149" L x 43" W x 60" H

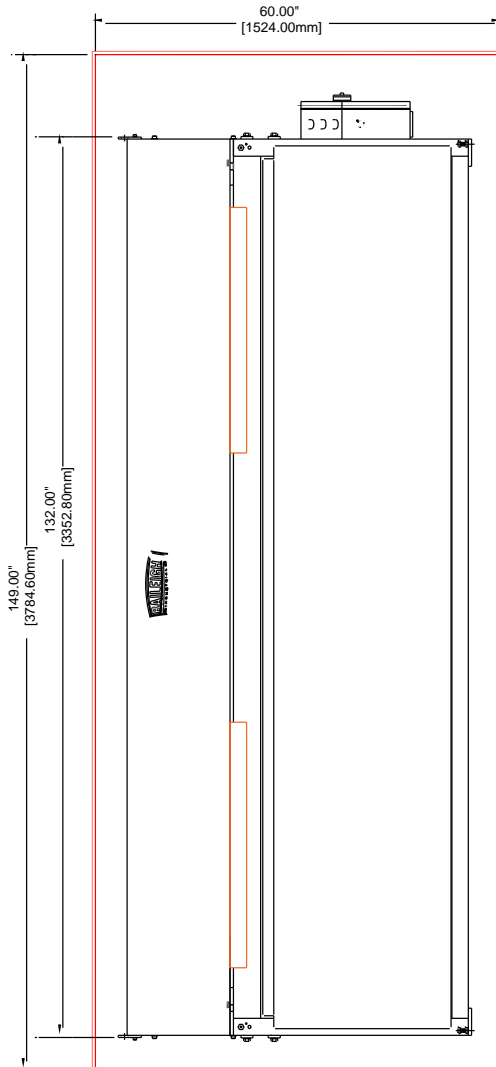
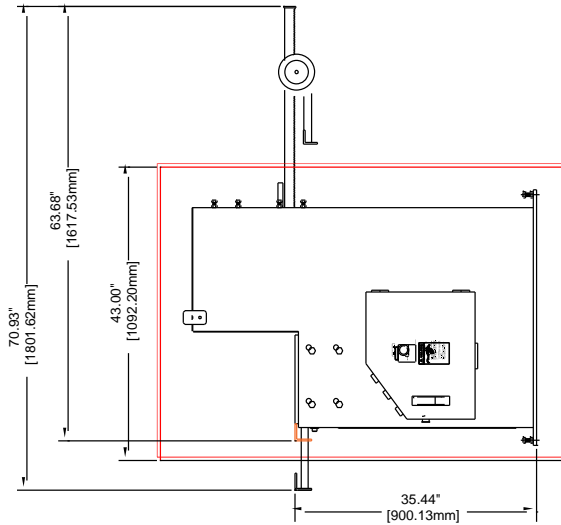



## GETTING TO KNOW YOUR MACHINE

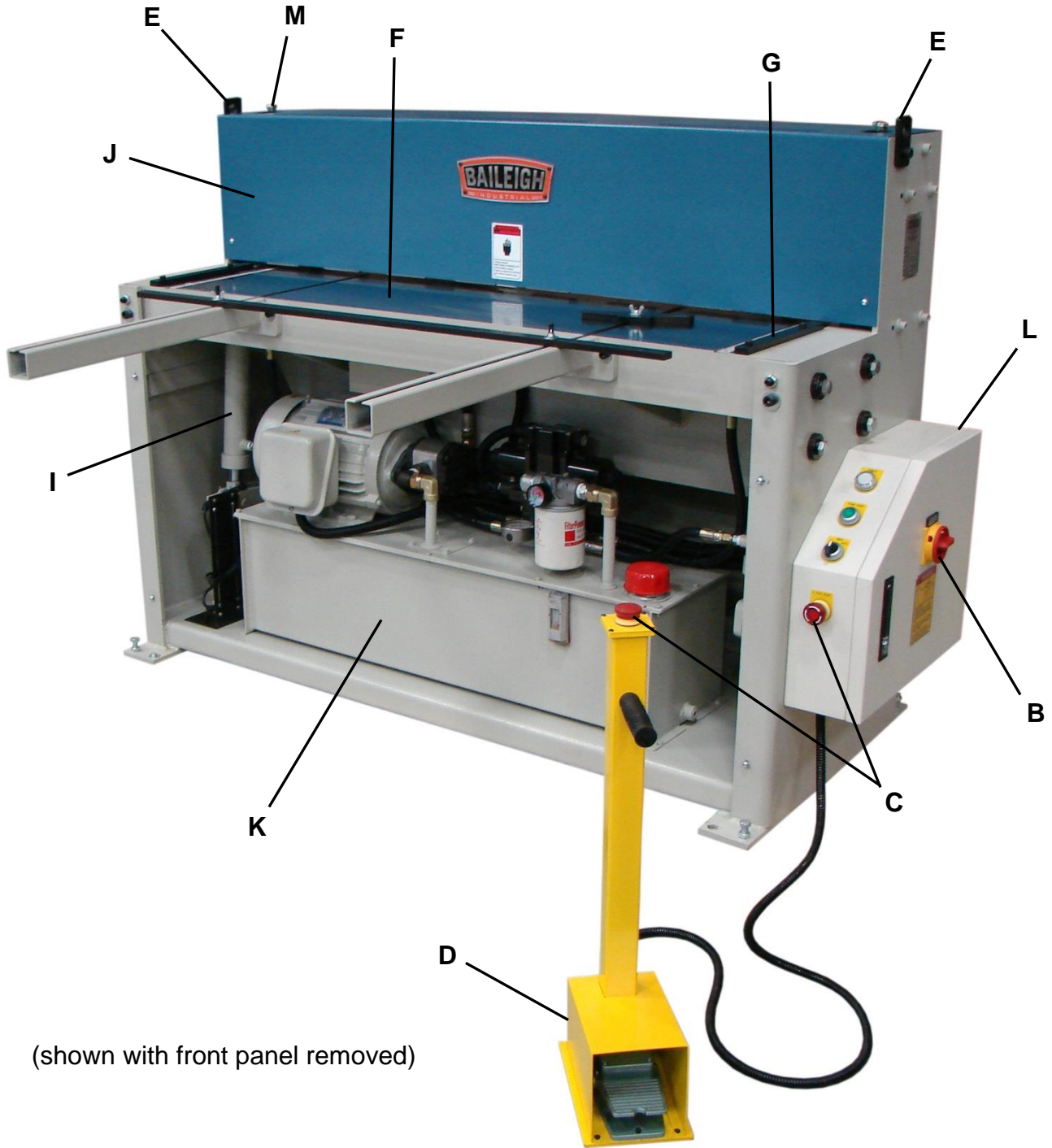

(shown with front panel removed)



**Note:** The photos and illustrations used in this manual are representative only and may not depict the actual color, labeling or accessories and may be intended to illustrate technique only.

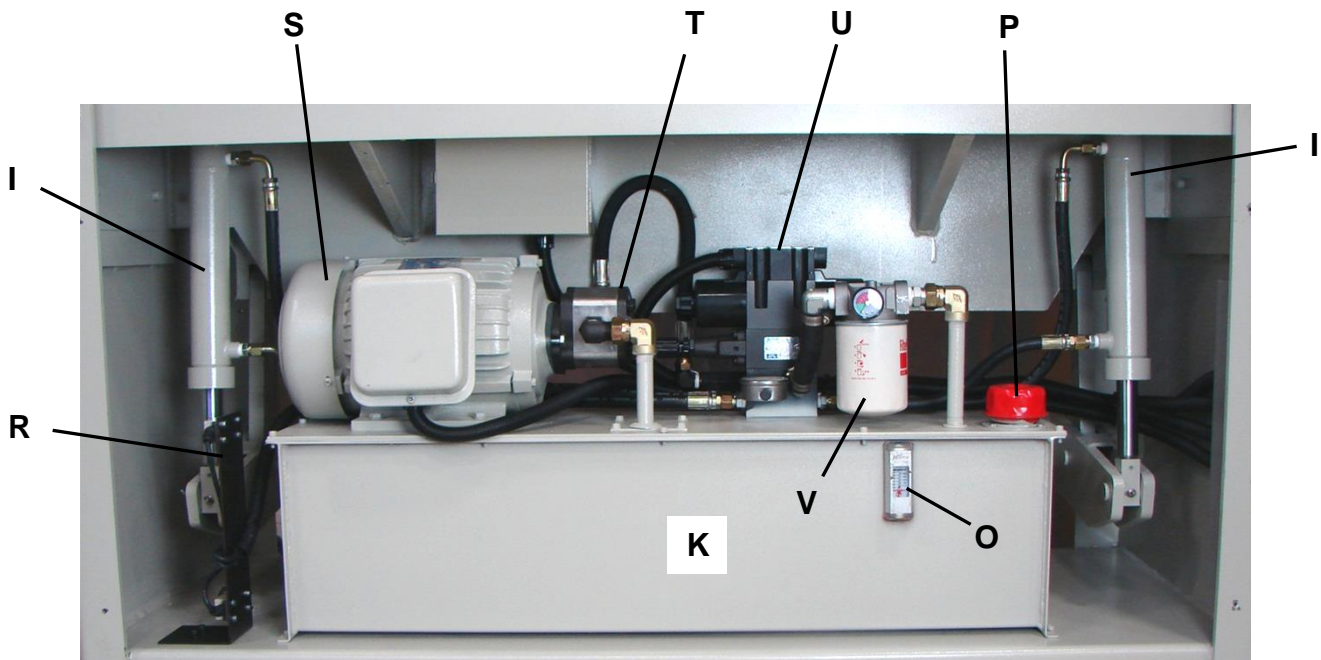

(shown with front panel removed)



Item	Description	Function
B	Disconnect switch	Controls main power to the shear
C	Emergency stop button	Press to stop all machine functions
D	Footswitch pedestal	Houses footswitch and "E"-stop button
E	Lifting brackets	Used for lifting machine
F	Shear table	For sliding material into shear blades
G	Side gauge	Keeps material perpendicular to blade
I	Hydraulic cylinder	Provides up-down motion for the upper blade
J	Hold down cover	Covers hold downs and upper blade travel
K	Hydraulic tank	Reservoir for hydraulic oil
L	Electrical enclosure	Houses electrical components
M	Oiling cap	Access to oiling the top blade slide
N	Back gauge	Adjustable angle for stopping material
O	Oil sight gauge	Indicates level of oil in hydraulic tank
P	Hydraulic oil fill cap	Remove cap to fill oil tank
Q	Transformer enclosure	Houses the transformer
R	Limit switches	For adjusting cylinder travel limits
S	Motor	Drives the hydraulic pump
T	Hydraulic pump	Used to circulate hydraulic oil to cylinders
U	Solenoid valves	Controls the flow of oil to the cylinders
V	Oil Filter	Keeps oil in the system clean



## Electrical Enclosure Switch and Button Functions

**POWER INDICATOR LIGHT** - When the disconnect switch is turned on, the white light will be lit. (Make sure machine is plugged into correct power source and that both “E”-Stop buttons have been reset.

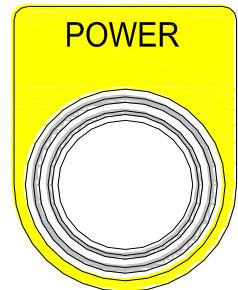

**PUMP START PUSHBUTTON** - When depressed, the green light on the “**PUMP START**” button will be lit and the pump motor will start. Press the footswitch pedal and the top blade should go down and return to the up position. (when in SIN (singular) mode).

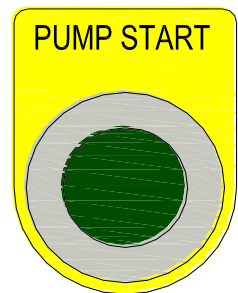

**CUTTING MODE SELECTOR SWITCH** – This is a 3-position selector switch which allows you to pick one of three shearing modes. Pressing (and holding down) the foot pedal in the **SIN** (singular) mode will complete one full shear cycle. In **INCH** mode the top blade can be stepped down gradually. Then hold the pedal down and when it reaches the bottom of the stroke, it will automatically raise up. In **AUTO** mode the upper blade will cycle continuously while holding down the pedal.



**E-STOP BUTTON** – When pressed, either red **E-STOP** button will stop all machine functions. The E-Stop button on the electrical enclosure will light up when pressed. The E-Stop button on the footswitch pedestal does not light up when pressed. Turn either button clockwise (**cw**) to reset.

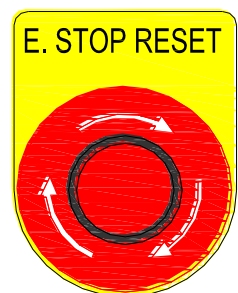



## Manual Back gauge

The back gauge adjusts the setting of the back gauge dimension to control the size of the pieces dropping behind the blades.

The manual back gauge assembly will need to be attached to the back end of the shear. There are two blocks with holes in them for this purpose. Remove the two bolts and washers (shown) and move the back gauge into position using a suitable lifting device. Slide the shafts into the blocks until they bottom out. If necessary, gently tap them in from side to side. Once in place, secure with the bolts and washers that were removed previously. To use the back gauge, loosen the two adjustable handles which are attached to the guide blocks. By turning the hand wheel you will now be able to move the stop angle into position. The scale and indicator allow you to keep track of that position. Secure with the adjustable handles.

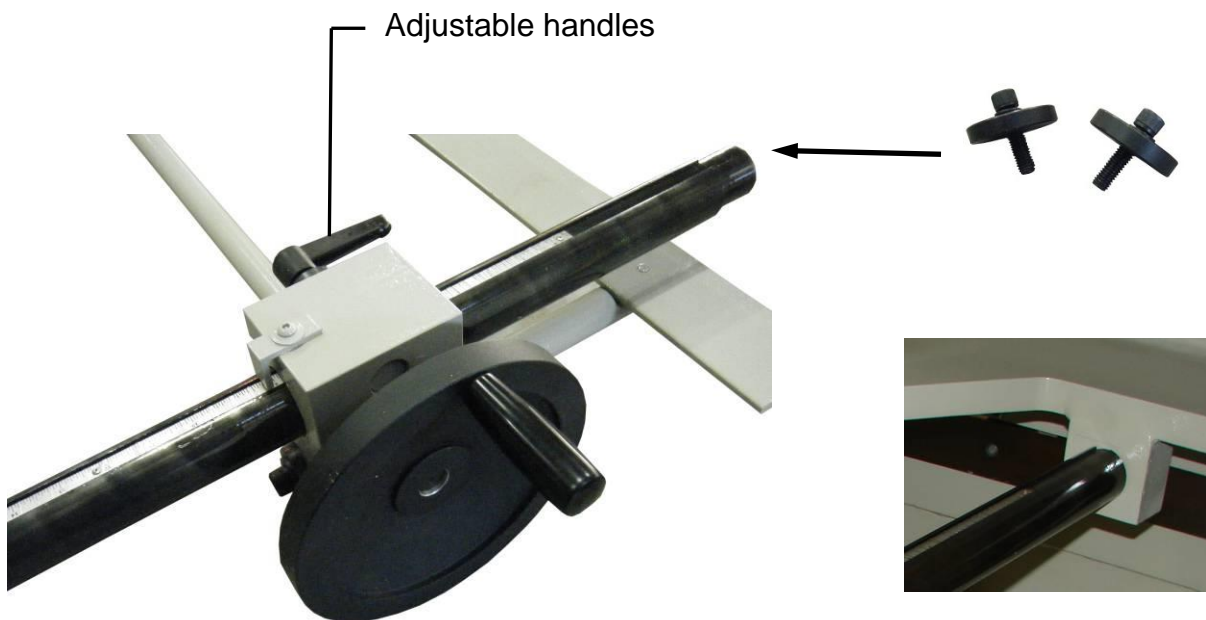



## Material Support Arm

**⚠ CAUTION:** When handling large piece parts, you may require assistance in handling the piece as it exits the blades. Failure to adequately support the piece part may result in the piece falling and causing bodily injury.

The two material support (**A**) are attached to the front of the shear on slide rods. The supports may be pushed in or pulled out as needed. The left support is shown pushed in and the right support is shown pulled out.

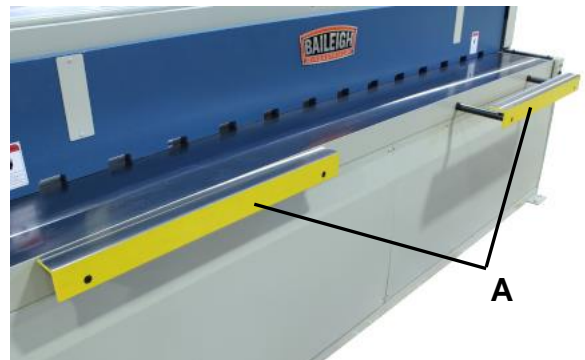

## Connecting cable to pedestal

Orientate the fittings and push them together. Turn the threaded ring clockwise (**cw**) until snug, ensuring a solid electrical connection.



## Miter Angle Guide

To use the miter angle guide:

- Loosen the wing nut.
- Lay your piece part against the straight edge.
- Position the miter guide at the angle and distance you required from the shear blades.
- Make the cut.

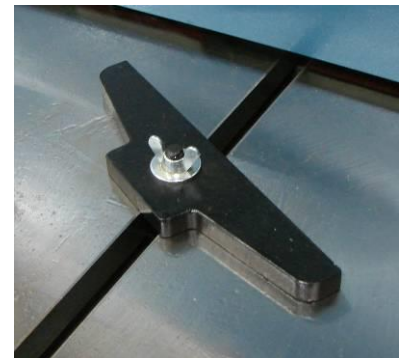



## ELECTRICAL

**⚠ WARNING:** Baileigh Industrial Holdings LLC is not responsible for any damage caused by wiring up to an alternative 3-phase power source other than direct 3-phase. If you are using an alternate power source, consult a certified electrician or contact Baileigh Industrial Holdings LLC prior to energizing the machine.

**⚠ CAUTION:** HAVE ELECTRICAL UTILITIES CONNECTED TO MACHINE BY A CERTIFIED ELECTRICIAN!  
Check if the available power supply is the same as listed on the machine nameplate.

**⚠ WARNING:** Make sure the grounding wire (green) is properly connected to avoid electric shock. DO NOT switch the position of the green grounding wire if any electrical plug wires are switched during hookup.

### Power Specifications

Your machine is wired for 220 volts, 60hz alternating current. Before connecting the machine to the power source, make sure the power source is OFF.

Before switching on the power, you must check the voltage and frequency of the power to see if they meet with the requirement, the allowed range for the voltage is  $\pm 5\%$ , and for the frequency is  $\pm 1\%$ .

### Considerations

- Observe local electrical codes when connecting the machine.
- The circuit should be protected with a time delay fuse or circuit breaker with an amperage rating slightly higher than the full load current of machine.
- A separate electrical circuit should be used for your machines. Before connecting the motor to the power line, make sure the switch is in the "OFF" position and be sure that the electric current is of the same characteristics as indicated on the machine.
- All line connections should make good contact. Running on low voltage will damage the motor.
- In the event of a malfunction or breakdown, grounding provides a path of least resistance for electric current to reduce the risk of electric shock. This machine is equipped with an electric cord having an equipment-grounding conductor and a grounding plug. The plug must be plugged into a matching outlet that is properly installed and grounded in accordance with all local codes and ordinances.



**⚠ WARNING:** In all cases, make certain the receptacle in question is properly grounded. If you are not sure, have a qualified electrician check the receptacle.

- Improper connection of the equipment-grounding conductor can result in risk of electric shock. The conductor with insulation having an outer surface that is green with or without yellow stripes is the equipment-grounding conductor. If repair or replacement of the electric cord or plug is necessary, do not connect the equipment-grounding conductor to a live terminal.
- Check with qualified electrician or service personnel if the grounding instructions are not completely understood, or if in doubt as to whether the machine is properly grounded.
- Repair or replace damaged or worn cord immediately.

**Power cord connection:**

1. Unlock and open the electrical enclosure door.
2. Insert a cord / cable fitting into an open hole in the electrical enclosure to grip the power cord (supplied by customer).
3. Route the power cord through the newly installed fitting and into the electrical enclosure.
  - a. Route the power cord so that it will NOT become entangled in the machine in any way.
  - b. Route the cord to the power supply in a way that does NOT create a trip hazard.
4. Connect the three power wires to terminals **R**, **S**, & **T**. Connect the ground wire (typically green) to the “**E**” (Safety Ground) terminal.
5. Check for correct rotation of motor and pump.
6. Check that the power cord has not been damaged during installation.

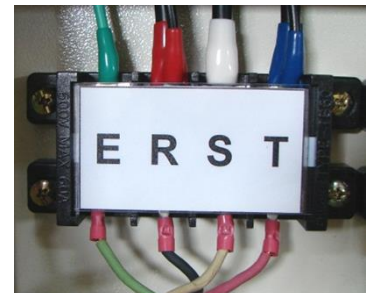

**Check for correct rotation of the motor**

7. Close the electrical enclosure door.
8. With power connected and the main disconnect turned ON, the power light on the control panel will be lit.
9. Verify that both “E”-STOP buttons are in the released / up position.
10. Turn the cutting mode selector switch to (**SIN**).
11. Press the green pump start button and briefly step on the footswitch. The shear blade should come down. If not, disconnect power to the machine, and switch the **R** & **T** wires. **DO NOT** move the ground wire **E**. **Improper rotation can severely damage the hydraulic pump.**



## **BLADE CLEARANCE**

The blade gap on the shear was set at the factory. At this setting it will shear mild steel up to 10ga. (3.41mm) and stainless steel up to 13ga. (2.28mm). To measure the blade gap, gradually lower the top blade and measure the gap going from left to right while facing the rear of the machine. The gap should be .005" (.13mm) with the blades perfectly parallel all the way across the cutting edges.

Gauge	Standard Steel Thickness	Aluminum Thickness	Knife Blade Clearance
3	0.2391 (6.073mm)	0.2294 (5.827mm)	.010"-.018" (.25-.45mm)
4	0.2242 (5.695mm)	0.2043 (5.189mm)	.009"-.013" (.23-.33mm)
5	0.2092 (5.314mm)	0.1819 (4.620mm)	.009"-.013" (.23-.33mm)
6	0.1943 (4.935mm)	0.162 (4.115mm)	.009"-.013" (.23-.33mm)
7	0.1793 (4.554mm)	0.1443 (3.665mm)	.008"-.011" (.20-.28mm)
8	0.1644 (4.176mm)	0.1285 (3.264mm)	.007"-.010" (.17-.25mm)
9	0.1495 (3.797mm)	0.1144 (2.906mm)	.006"-.009" (.15-.23mm)
10	0.1345 (3.416mm)	0.1019 (2.588mm)	.006"-.009" (.15-.23mm)
11	0.1196 (3.038mm)	0.0907 (2.304mm)	.004"-.008" (.10-.20mm)
12	0.1046 (2.657mm)	0.0808 (2.052mm)	.004"-.008" (.10-.20mm)
13	0.0897 (2.278mm)	0.072 (1.829mm)	.003"-.006" (.076-.152mm)
14	0.0747 (1.897mm)	0.0641 (1.628mm)	.003"-.006" (.076-.152mm)
15	0.0673 (1.709mm)	0.0571 (1.450mm)	.003"-.006" (.076-.152mm)
16	0.0598 (1.519mm)	0.0508 (1.290mm)	.002"-.005" (.05-.127mm)
17	0.0538 (1.367mm)	0.0453 (1.151mm)	.002"-.005" (.05-.127mm)
18	0.0478 (1.214mm)	0.0403 (1.024mm)	.002"-.004" (.05-.10mm)
19	0.0418 (1.062mm)	0.0359 (0.912mm)	.002"-.004" (.05-.10mm)
20	0.0359 (0.912mm)	0.032 (0.813mm)	.002"-.004" (.05-.10mm)
21	0.0329 (0.836mm)	0.0285 (0.724mm)	.002"-.004" (.05-.10mm)
22	0.0299 (0.759mm)	0.0253 (0.643mm)	.002"-.004" (.05-.10mm)
23	0.0269 (0.683mm)	0.0226 (0.574mm)	.001"-.003" (.025-.076mm)
24	0.0239 (0.607mm)	0.0201 (0.511mm)	.001"-.003" (.025-.076mm)

**Under no circumstances do you want the blades making contact with each other as this can cause blade breakage as well as premature dulling of the cutting edges.**



**Note:** This is a general guide for setting the blade gap. Your specific settings may change based upon several factors regarding specific material and other machine settings and conditions. This is based upon a general guideline of blade gap is equal to 6.5%-7% of material thickness.



## **SHEARING STRENGTH OF MATERIALS**

- How to use this table: The shear is rated 10ga. (.1345") in mild steel. What thickness can it cut of other materials?  $(.1345) \times (\text{material factor}) = \text{materials thickness}$ .

MATERIAL	TONS/SQ. IN.	FACTOR
Mild Steel (.25 Carbon)	25	1.00
Mild Steel (.50 Carbon)	30	0.83
Stainless Steel	38	0.65
Boiler Plate	30	0.83
Spring Steel (1.99 Carbon)	42	0.60
Tool Steel - Not Tempered (1.20 Carbon)	45	0.56
Tool Steel - Tempered (1.20 Carbon)	95	0.26
Nickel Steel (0.5% Nickel)	41	0.61
Aluminum Sheet	10	2.50
Brass	13	1.92
Copper	12.5	2.00
Lead	1.5	16.67
Tin - Coated Sheet Steel	25	1.00
Zinc	8.5	2.94
Galvanized Steel Sheet	25	1.00



## SHEARING OPERATION

**⚠ WARNING:** Always wear proper eye protection with side shields, safety footwear, and leather gloves to protect from burrs and sharp edges. The shearing blade poses an amputation hazard. Make sure no body part or clothing is near the specific hazard. Failure to follow this warning could result in severed or crushed fingers.

1. When planning your cut, either scribes a line on the material or use the side scale which measures the distance to the blade.
2. The scale is graduated in both inches and millimeters.
3. If you have a scribed line, use the slot indicated in (fig. 17) to sight the line to the edge of the blade.
4. In both instances, use the side guide to square the material to the blade.
5. After the material is lined up, step on the foot pedal to make the cut.
6. If you are making multiple pieces of the same length, set the rear stop to the length needed.
7. If the material exceeds the length of the extension arms, be sure and provide additional support.



figure 17

### Shearing Tips

- To achieve the best results, never shear a piece narrower than 8 times the thickness of the material. An example would be a 1/2" (12.7mm) strip of 16 ga. (.059") (1.5mm) mild steel.
- Keep the blade gap as narrow as possible. The blade gap is the space between the blades passing each other during a stroke. Tighter blade gaps cut material without rolling it over. Using a blade gap too narrow for thicker material prevents the material from moving between the blades and stalls the cut. On the other hand, a gap too wide will cause the material to fold over. The wide gap for thinner material does not set the blades close enough to cleanly cut the material.



## **SHEAR OPERATING PROCEDURE**

### **Start Machine Power**

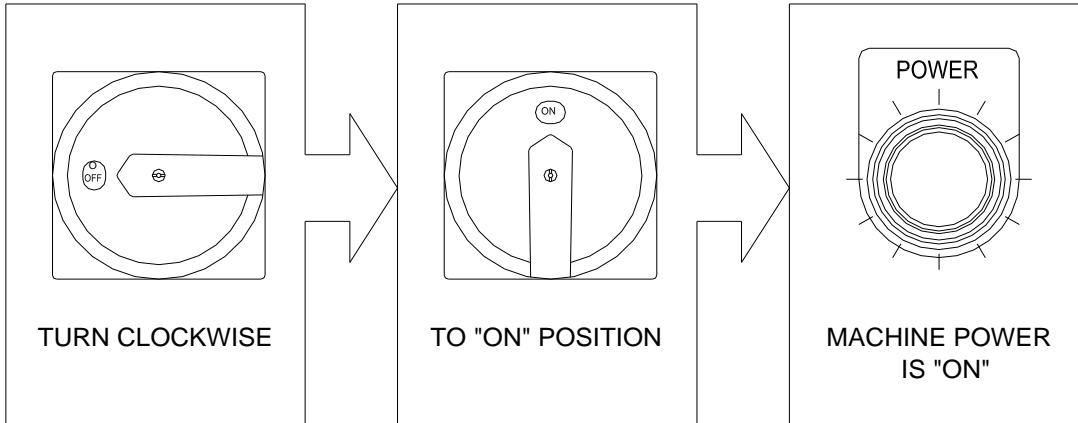

### **Start Hydraulic Pump Motor**

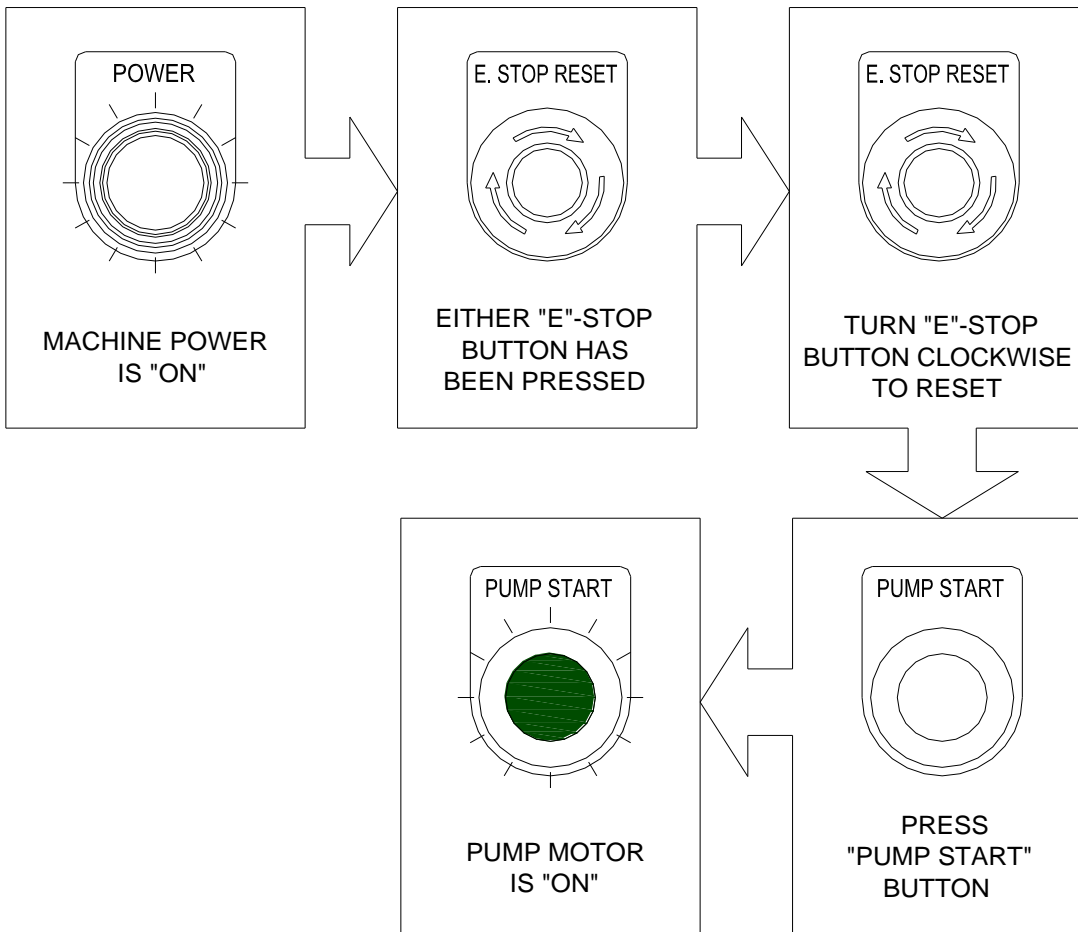



## Single Mode

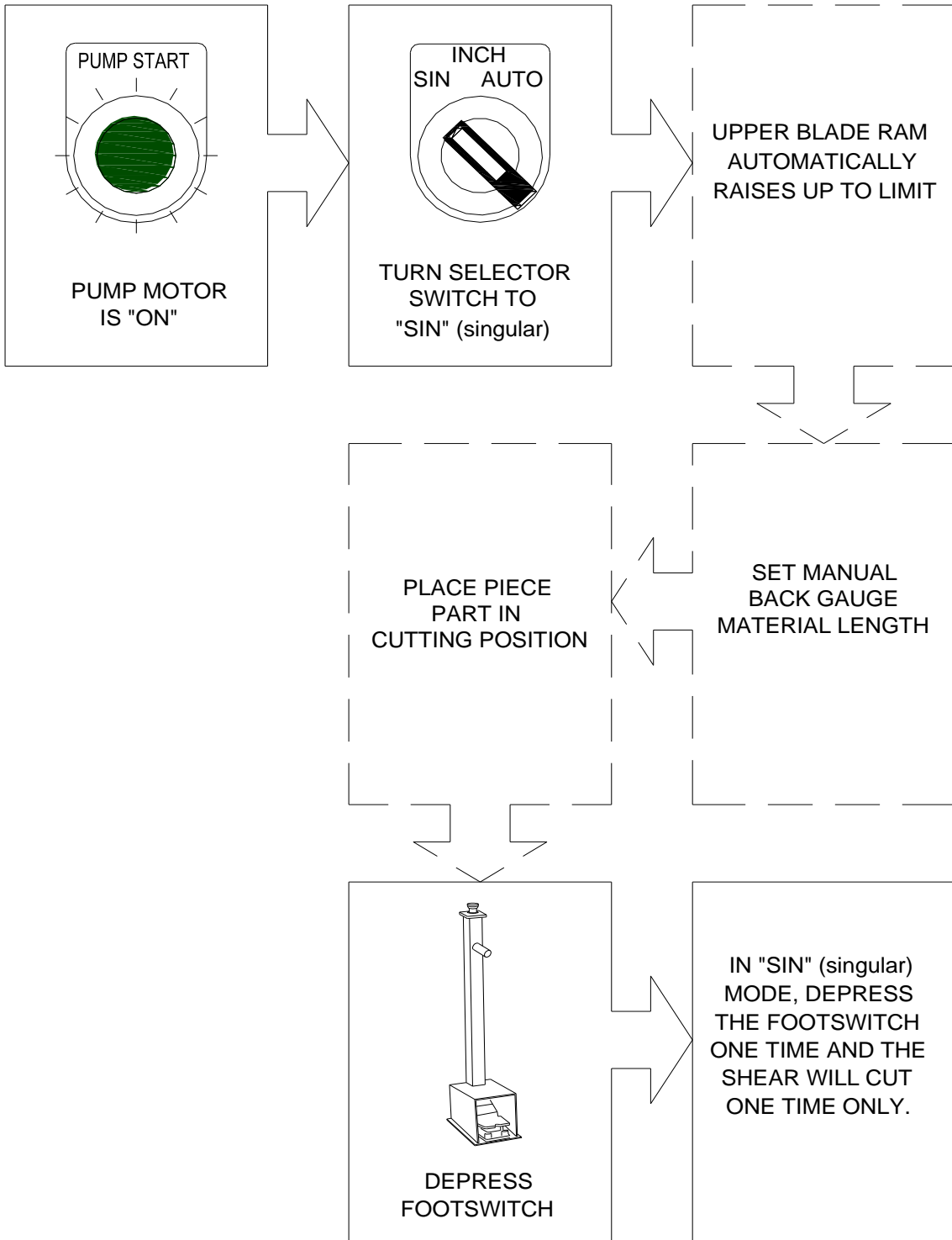



## Auto Mode

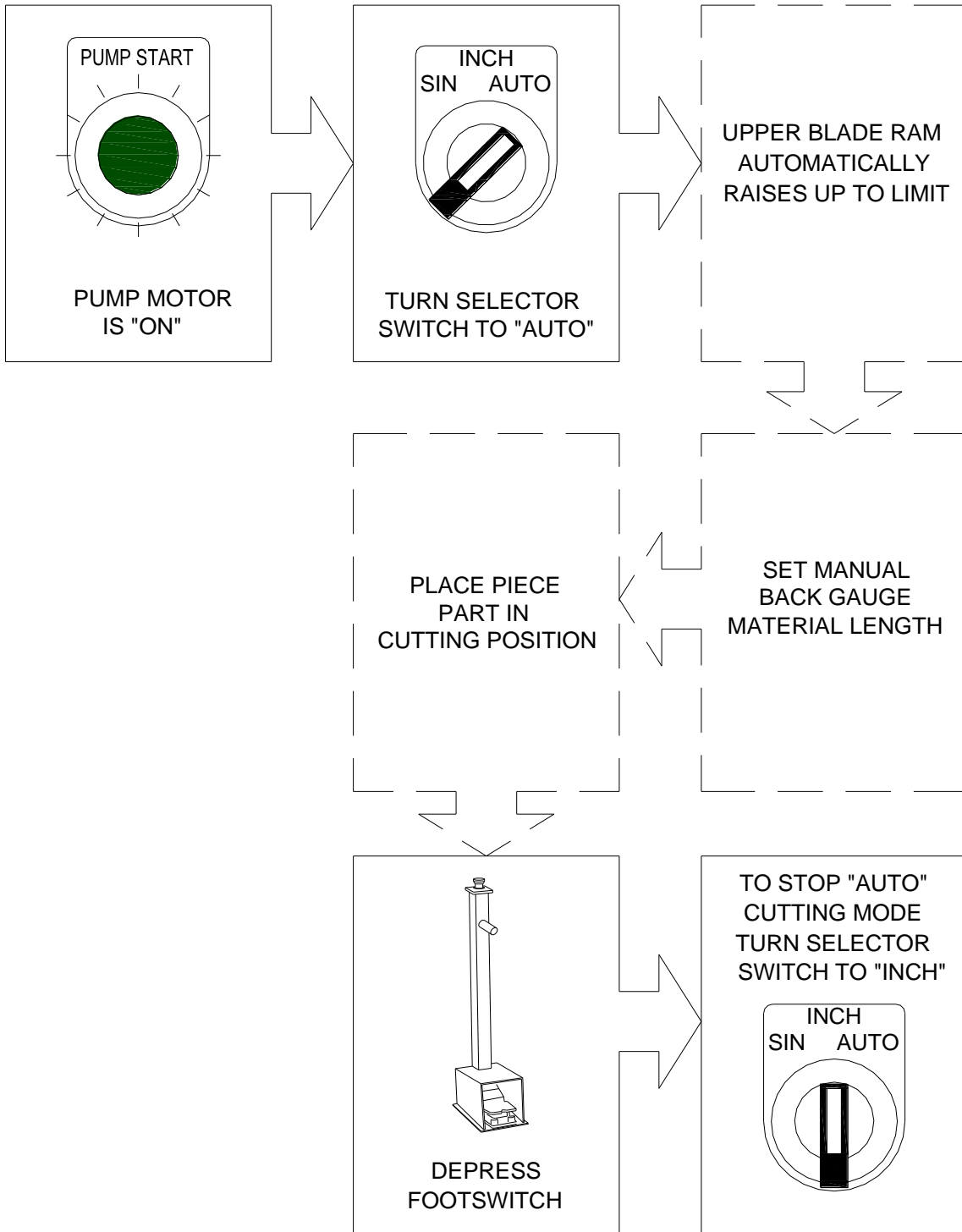



## Turning Off Machine Power

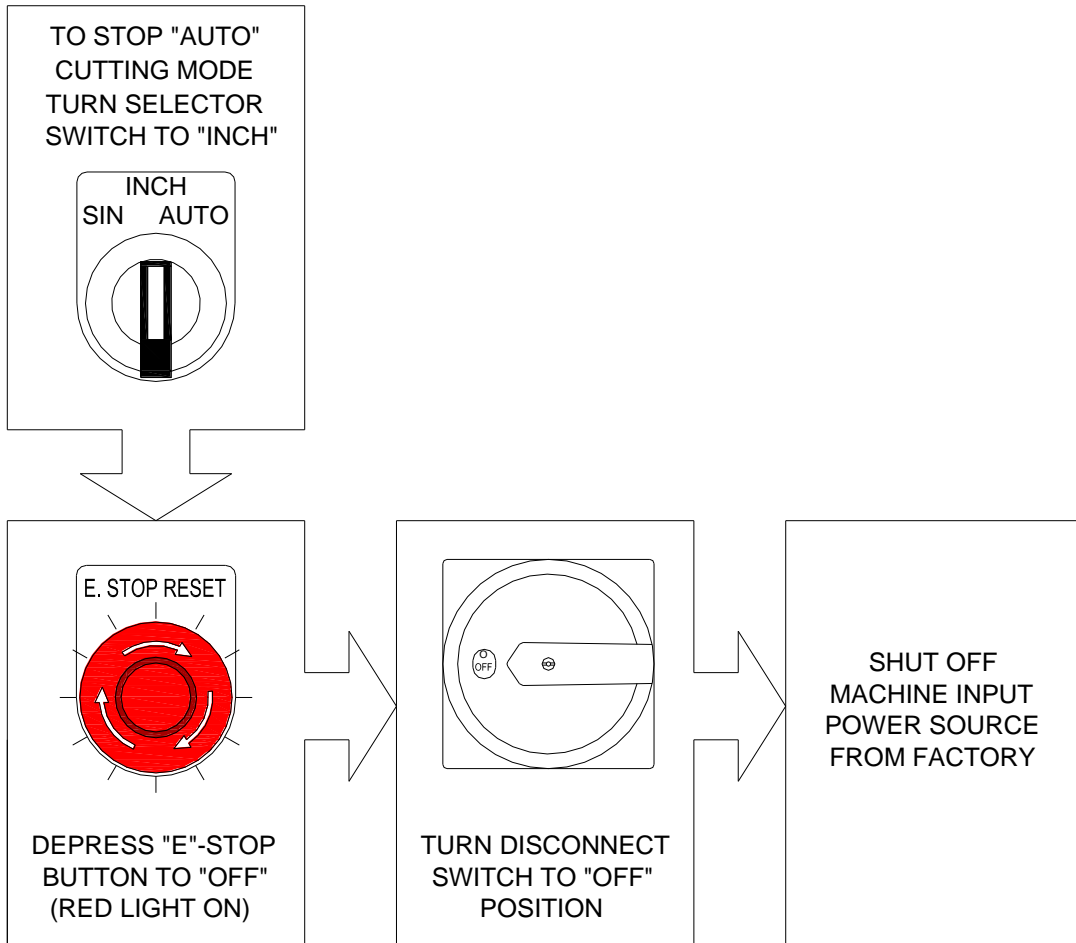



## **LUBRICATION AND MAINTENANCE**



**WARNING:** Make sure the electrical disconnect is OFF before working on the machine.

Maintenance should be performed on a regular basis by qualified personnel.

Always follow proper safety precautions when working on or around any machinery.

### **Initial Start Up**

- Check for any unsafe conditions and fix immediately.
- Check that all nuts and bolts are properly tightened.
- Fill hydraulic tank with oil.
- Test run the shear for proper motor rotation.
- Test that the emergency stop button will stop machine operation.

### **Daily Maintenance**

- Check daily for any unsafe conditions and fix immediately.
- Check that all nuts and bolts are properly tightened.
- Inspect the power plug and cord.
- Check the foot switch cable for any loosening or damage.
- Keep area around machine clear of debris.

### **Weekly Maintenance**

- Make sure limit switches are secure and adjusted properly.
- Check hydraulic hoses and fittings for leakage.
- Make sure grease fitting locations are kept lubricated.
- Check back gauge components for lubrication.
- On a weekly basis clean the machine and the area around it.
- Lubricate threaded components and sliding devices.
- Apply rust inhibitive lubricant to all non-painted surfaces.



**Note:** *Proper maintenance can increase the life expectancy of your machine.*



## Lubrication Locations

Located at each end on the top of the shear are two oil fill caps. Keep filled with oil such as Mobil Vactra #2 way oil (or equivalent). The wick inside the fitting helps to slowly distribute the oil to the slide ways.



A grease fitting as shown in the figure at right, is located at both ends of the shear. They provide grease for lubricating the shaft which rotates as the slide goes up and down.

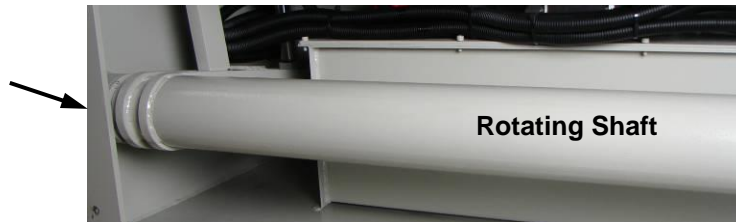

(Shown with panel removed)



Grease the trunnion which is located at the end of the rod on each cylinder.

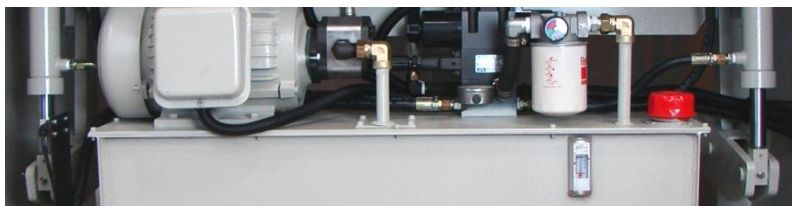

(Shown with panel removed)





## **Hydraulic Oil**

The hydraulic oil is the primary medium for transmitting pressure and also must lubricate the running parts of the pump.

After installation of the machine and before machine startup, bring the oil level up to 90% of capacity. **A shortage of hydraulic oil can cause hydraulic system breakdown and damage to major mechanical parts due to overheating.**

1. Use SHELL BRAND #46 or #68 hydraulic oil or an equivalent with similar specifications. (Based upon location temperature and availability.)
2. Keep hydraulic reservoir filled to 90% of capacity.
3. **DO NOT** rely totally on the oil gauge as they can sometimes indicate an incorrect level reading. Do a visual inspection with the oil fill cap removed as well.
4. A shortage of hydraulic oil will cause hydraulic system breakdown to major mechanical components due to overheating.
5. Change the hydraulic oil every 6 months along with the oil filter.

## **Oil Change and Disposal**

Change the oil in the hydraulic tank after the first 6 months, and every 12 months after that. Clean the filter basket located under the fill cap before refilling the tank. Used oil products must be disposed of in a proper manner following your local regulations.



## Filter and Oil Change

Take off and clean the suction strainer inside the hydraulic tank every time the oil is changed. The first oil change should be performed after approximately 600 operating hours. Further oil changes are needed every 1200 operating hours. An outlet (**W**) is located at the base of the tank for draining the oil. Dispose of dirty oil following local ordinances in your area. Attach the cleaned suction strainer after draining the oil. (If the strainer is damaged or clogged it must be replaced to avoid damage to the pump).

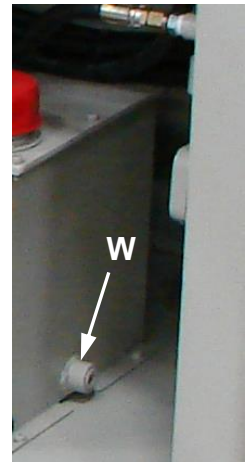

Check to make sure the hydraulic oil level is in the range as indicated on the oil level sight gauge (**O**). Keep close to the high mark.

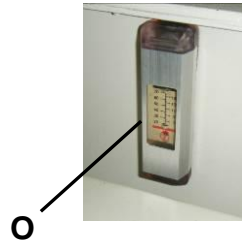

Replace the spin-on filter (**V**) at each oil change with the same or equivalent filter.



Take off the fill cap (**P**) and remove the plastic strainer basket (**X**). Clean thoroughly before replacing and filling the tank with Shell Tellus 68 or equivalent hydraulic oil.





## REPLACING THE SHEAR BLADES

The blades on the Baileigh SH-12010 have multiple usable edges. If you have not already used both cutting edges on the top blade you can rotate it end for end to expose a sharp edge. The bottom blade has four usable edges. After all edges have been used, the blade can be reground or replaced.

Contact Baileigh Industrial at (920.684.4990) for replacement blades.

### To Rotate or Replace the Top Blade

1. Raise the top blade to the up position.
2. Shut down and lockout power to the machine.



**CAUTION:** Always wear leather gloves when handling the blade.

3. Remove the capscrews and washers that hold the blade in place.
4. Turn the blade end for end if the other side is sharp, or replace the blade.
5. When the blade is in position, secure with the bolts and washers that were removed in step 3.
6. Set the gap to .005" (.12mm) making sure the blades are parallel along the entire length.
7. The blade gap adjustment screws (Y) were preset at the factory. **ADJUST ONLY IF ABSOLUTELY NECESSARY.** To adjust, loosen the hex nut and turn the setscrew clockwise (**cw**) to close the blade gap and counterclockwise (**ccw**) to open the gap. After adjustment re-tighten the hex nut.
8. Blade clearances can also be adjusted by moving the table IN or OUT. To push the table IN (closing the blade gap), loosen the socket bolt (**Z**). Loosen the nut on socket screw (**AA**) and turn the setscrew clockwise (**cw**). To pull the table back (opening the blade gap), back-off setscrew (**AA**) and turn socket bolt (**Z**) clockwise (**cw**).
9. Check clearances after tightening the table bolts.

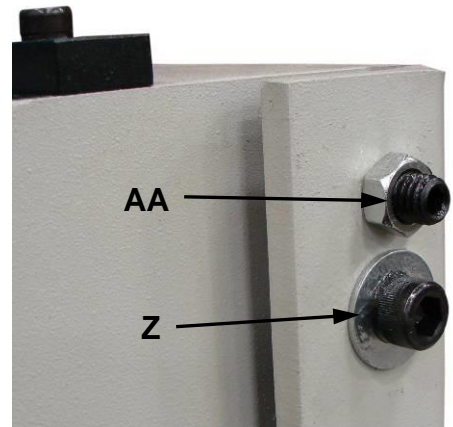
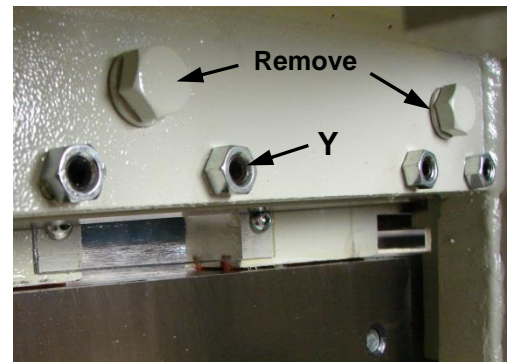



## To Rotate or Replace the Bottom Blade

**⚠ WARNING:** Always wear proper eye protection with side shields, safety footwear, and leather gloves to protect from burrs and sharp edges. The shearing blade poses an amputation hazard. Make sure no body part or clothing is near the specific hazard. Failure to follow this warning could result in severed or crushed fingers.

1. Raise the top blade to the up position.
2. Shut down and lockout power to the machine.
3. Remove the front panel of the machine.
4. To remove the blade, take out the (nine) hex bolts (**AB**) and washers as shown below.

**⚠ CAUTION:** Make sure there is someone on the back side of the machine to handle the blade so it does not fall and get damaged.

5. Turn the blade if you have not already used all four cutting edges, or replace the blade with a new one.
6. When in position, secure the blade with the bolts and washers. The bottom blade has no adjustment.
7. Check that the clearance between the upper and lower blades is at .005" (.12mm) and that the blades are parallel to each other along the full length.
8. The blade gap adjustment screws (**Y**) were preset at the factory. **ADJUST ONLY IF ABSOLUTELY NECESSARY.** To adjust, loosen the hex nut and turn the setscrew clockwise (**cw**) to close the blade gap and counterclockwise (**ccw**) to open the gap. After adjustment re-tighten the hex nut.
9. Blade clearances can also be adjusted by moving the table IN or OUT. To push the table IN (closing the blade gap), loosen the socket bolt (**Z**). Loosen the nut on socket screw (**AA**) and turn the setscrew clockwise (**cw**). To pull the table back (opening the blade gap), back-off setscrew (**AA**) and turn socket bolt (**Z**) clockwise (**cw**).
10. Check clearances after tightening the table bolts.

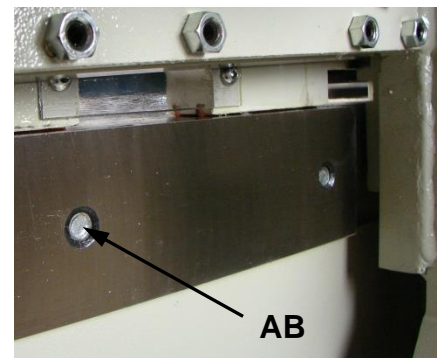
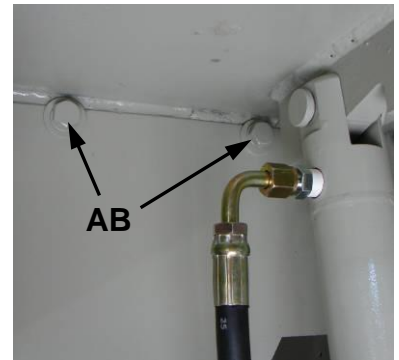



## **BLADE CARE**

The blades are made from High Carbon / High-Chrome Alloy tool steel. The multiple shearing edges available will prolong blade life considerably. NEVER allow the blades to contact one another. Lubricate the blade with a light oil when shearing stainless steel or galvanized material. Brush oil on the lower blade as the upper blade will pick up oil during the shearing cycle. It is very important to keep the blades sharp. Turn or change the blades when you begin to notice a burr on the sheared piece part. It is a good idea to keep a spare set of blades on hand so as not to hold up your operation.

## **RAM WAYS ADJUSTMENT**

The ram ways are adjustable to compensate for wear which can be expected after years of service. Premature wear can occur if the machine is not properly leveled which causes a twisting action.

The proper running clearance should be from 0.001" - 0.002" (0.038 - 0.050mm). This clearance should be checked periodically and maintained to extend blade life and to hold accuracy of the shear.

### **Adjustment Procedure**

1. Shut down and lockout power to the machine.
2. Loosen the jam nuts on all four hex bolts.
3. Turn in the two center hex bolts clockwise (**cw**) to take up any excess play.
4. Turn in the top and bottom hex bolts clockwise (**cw**) until they strike the wear plate, and then back off 1/16 of a turn counterclockwise (**ccw**).
5. Back-off on the two center hex bolts until they come in line with the top and bottom hex bolts.
6. Tighten all four jam nuts.
7. Using a feeler gauge between the wear plate and the ram guide check for a clearance of 0.001" - 0.002" (0.038 - 0.050mm). Adjust if necessary.
8. Repeat this procedure for the opposite side of the shear.





## FINGER GUARD

**⚠ WARNING:** DO NOT remove the clear plastic finger guards under any circumstances. They are provided to keep your fingers away from the blades. **NEVER** put any part of your body under or behind this guard and in the path of the hold downs which can crush.

## MATERIAL SELECTION

**⚠ CAUTION:** It must be determined by the customer that materials being processed through the machine are **NOT** potentially hazardous to operator or personnel working nearby.

When selecting materials keep these instructions in mind:

- Material must be clean and dry. (without oil)
- Material should have a smooth surface so it processes easily.
- Dimensional properties of material must be consistent and not exceed the machine capacity.
- Chemical structure of material must be consistent.
- Buy certificated steel from the same vendor when possible.



**MANIFOLD BLOCK**

M	S	S1	S2
CUTTING, HOLD-DOWN DOWN			▲
BLAND UP		▲	

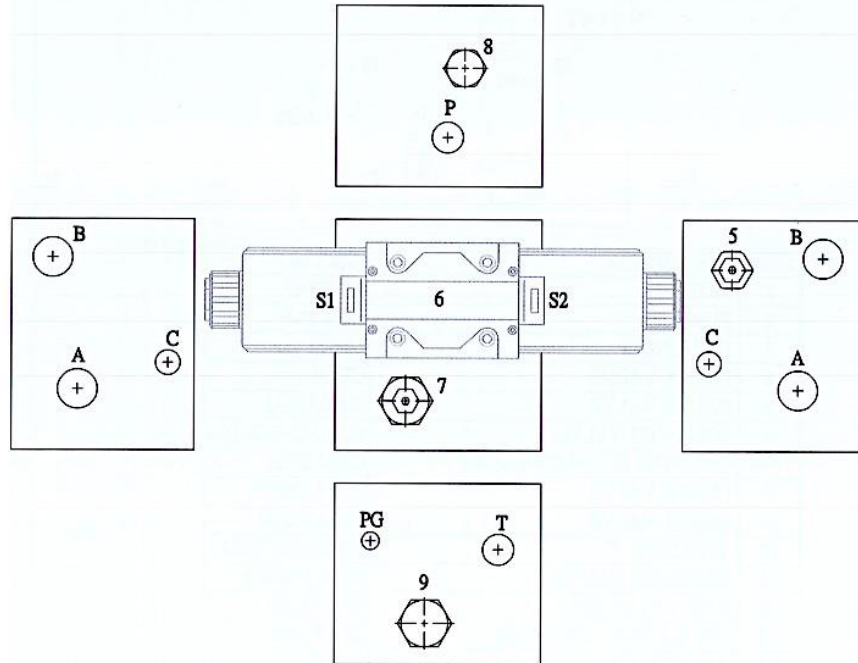

**Hydraulic Parts List**

Item	Description	Part Information
1	Motor	7.5Hp (5.59Kw) 220V 60Hz 3Ph
2	Pump	EGB-19-R
3	Strainer	MF-10
4	Check Valve	CV-04
5	Relief Valve	RP10A20AL
6	Solenoid Operated Directional Valve	SDSG-03-3C6-D24
7	Counterbalance Valve	CB2A33BL
8	Check Valve	CV13A2050N
9	Check Valve	CC2A3020N
10	Strainer	CG050-P10/70134
11	Pressure Gauge	AT-63Øx250Kg
12	Hydraulic Cylinder, Shearing	70Ø x 215St
13	Hydraulic Cylinder, Hold Down	45Ø x 15St
14	Air Breather	HY-08
15	Oil Level w/Thermometer	LG-3A



# HYDRAULIC SCHEMATIC

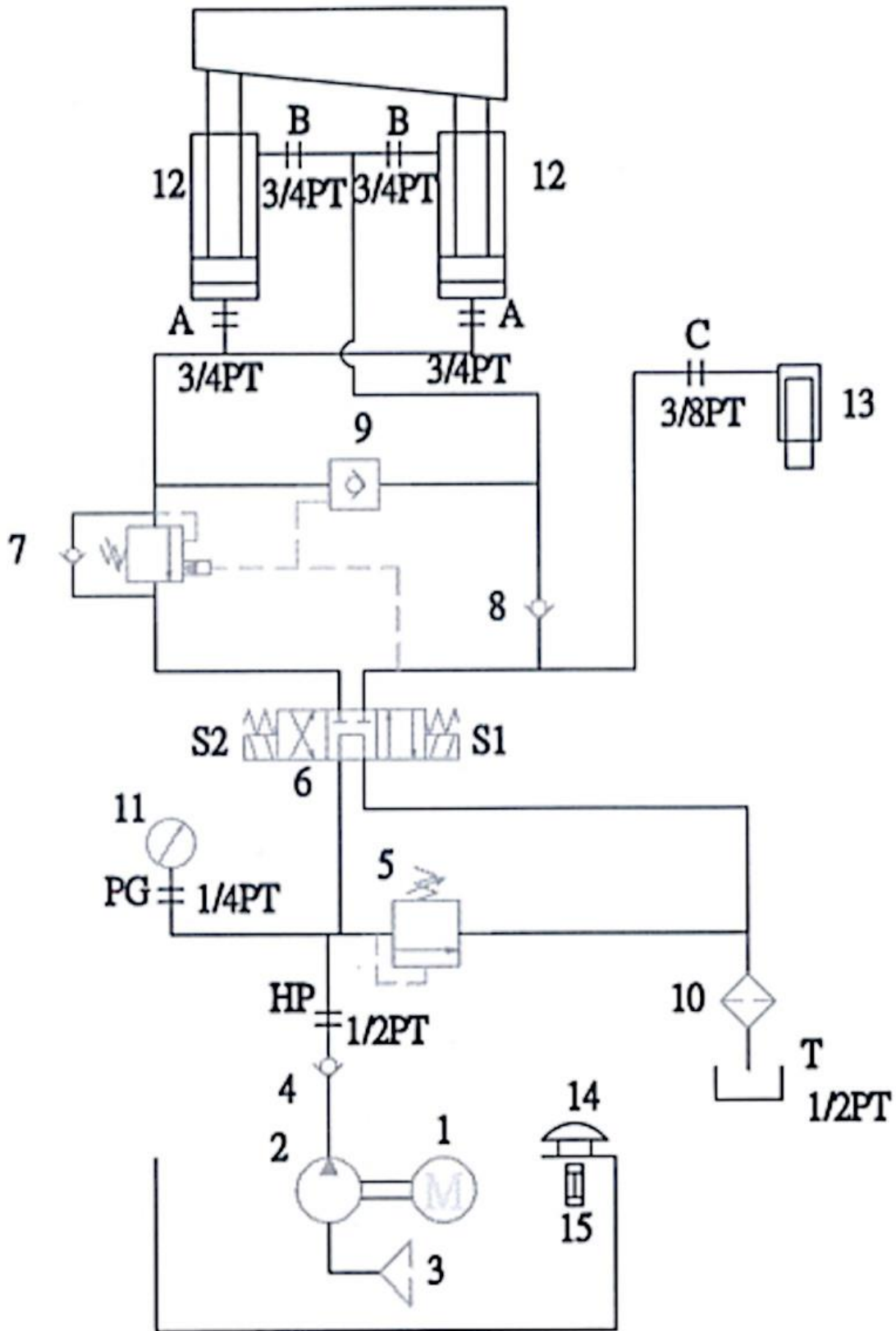

**PARTS IDENTIFICATION DRAWING A**

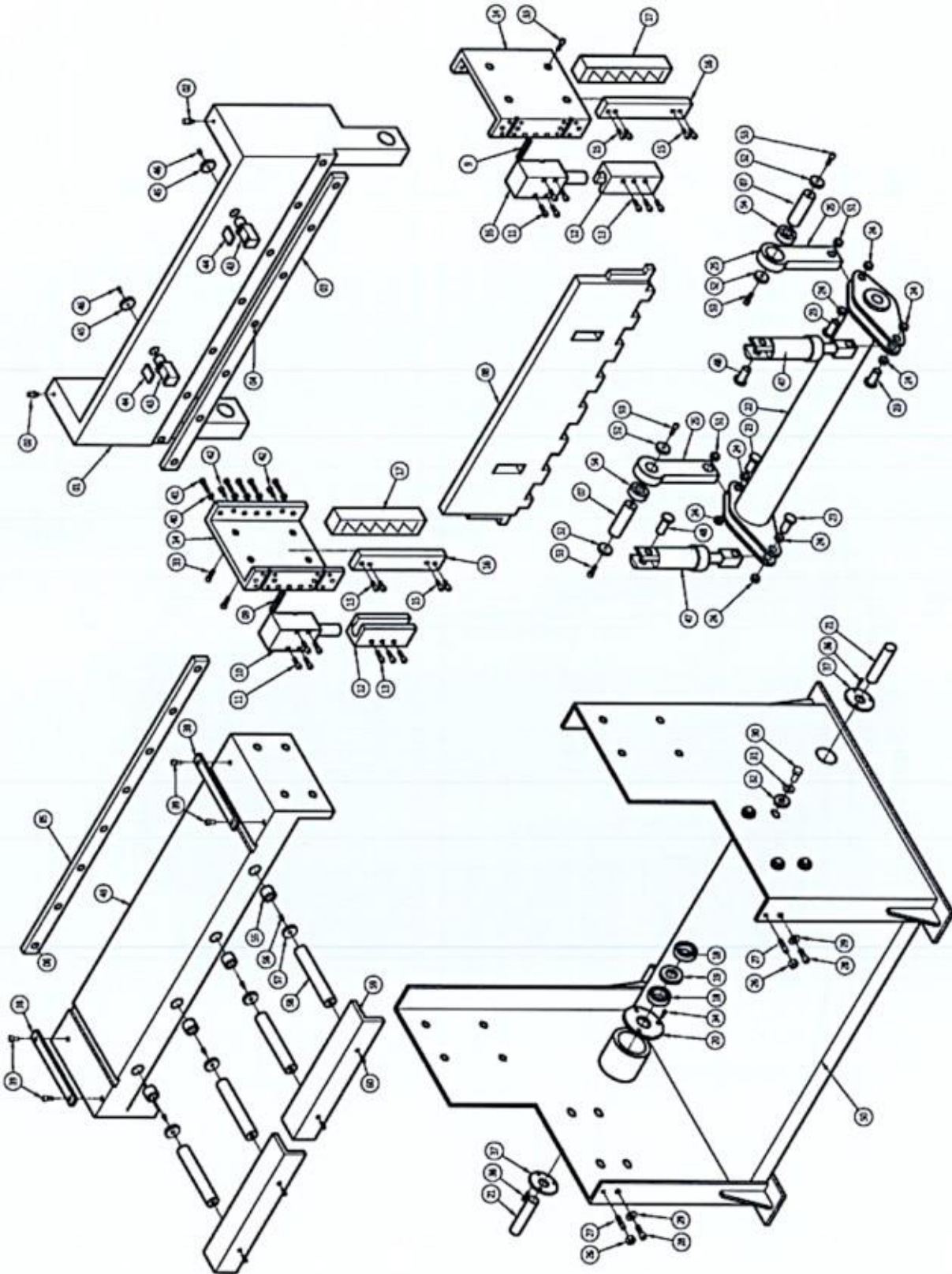



## Parts List

Item	Part No.	Description	Qty
1	SH12010-1	Upper Beam Assembly	1
2	SH12010-43	Oil Cup	2
3	SH12010-BLADE SET	Upper Knife Blade, Use full set part number	1
4	SH12010-4	1/2" Hex Head Capscrew	8
5	SH12010-BLADE SET	Lower Knife Blade, Use full set part number	1
6	SH12010-4	1/2" Hex Head Capscrew	8
7	SH12010-7	Pin	2
8	SH12010-8	Hold Down	1
9	SH12010-9	Key	2
10	SH12010-10	Hold Down Cylinder-Left Side	1
11	SH12010-11	Screw	8
12	SH12010-12	Side Guidance	2
13	SH12010-13	Screw	6
14	SH12010-14	Slide Housing	2
15	SH12010-15	Copper Screw	8
16	SH12010-16	Hard Wearing Plastic	2
17	SH12010-17	Slide Block	2
18	SH12010-18	Bearing	4
19	SH12010-19	Spacer	2
20	SH12010-20	Cover	2
21	SH12010-21	Pin	2
22	SH12010-22	Bottom Balance Bar	1
23	SH12010-23	Pin	4
24	SH12010-24	Bushing DU 20 x 16mm	8
25	SH12010-25	Link Plate	2
26	SH12010-26	Nut 1/2"	2
27	SH12010-27	Stud 1/2" x 1.5" lg.	2
28	SH12010-28	Soc. Head Capscrew 1/2"	2
29	SH12010-29	Washer 1/2"	2
30	SH12010-30	Hex Head Capscrew 5/8" x 1.5" lg.	8
31	SH12010-31	Flat Washer 5/8"	8
32	SH12010-32	Spacer	8
33	SH12010-33	Soc. Head Capscrew 3/8" x 1.25"	8



Item	Part No.	Description	Qty
34	SH12010-34	Screw	3
35	SH12010-35	Hold Down Cylinder-Right Side	1
36	SH12010-36	Soc. Button Head M6 x 16mm	6
37	SH12010-37	Cover	2
38	SH12010-38	Plate Shear Guide	2
39	SH12010-39	Screw	4
40	SH12010-40	Hex Nut M12	8
41	SH12010-41	Adjusting Screw Hex Head Capscrew M12	8
42	SH12010-42	Soc. Head Capscrew 3/8 x 1.25"	4
43	SH12010-43	Hold Down Supporting Pillow	2
44	SH12010-44	Urethane Pad	2
45	SH12010-45	Shaft Filler Washer	2
46	SH12010-46	Screw	2
47	SH12010-47	Hydraulic Cylinder	2
48	SH12010-48	Cylinder Pin	2
49	SH12010-49	Table Platen	1
50	SH12010-50	Bottom Base Assembly	1
51	SH12010-51	Bushing	2
52	SH12010-52	Shaft Filler Washer	4
53	SH12010-53	Screw	4
54	SH12010-54	Bearing	2
55	SH12010-55	Bushing	4
56	SH12010-56	Screw	4
57	SH12010-57	Shaft Filler Washer	4
58	SH12010-58	Extension Bar	4
59	SH12010-59	Work Piece Support	2
60	SH12010-60	Screw	4
	SH12010-TSL	Top Shroud-Left	1
	SH12010-TSR	Top Shroud-Right	1
	SH12010-FCL	Front Cover-Left	1
	SH12010-FCR	Front Cover-Right	1



## PARTS IDENTIFICATION DRAWING C

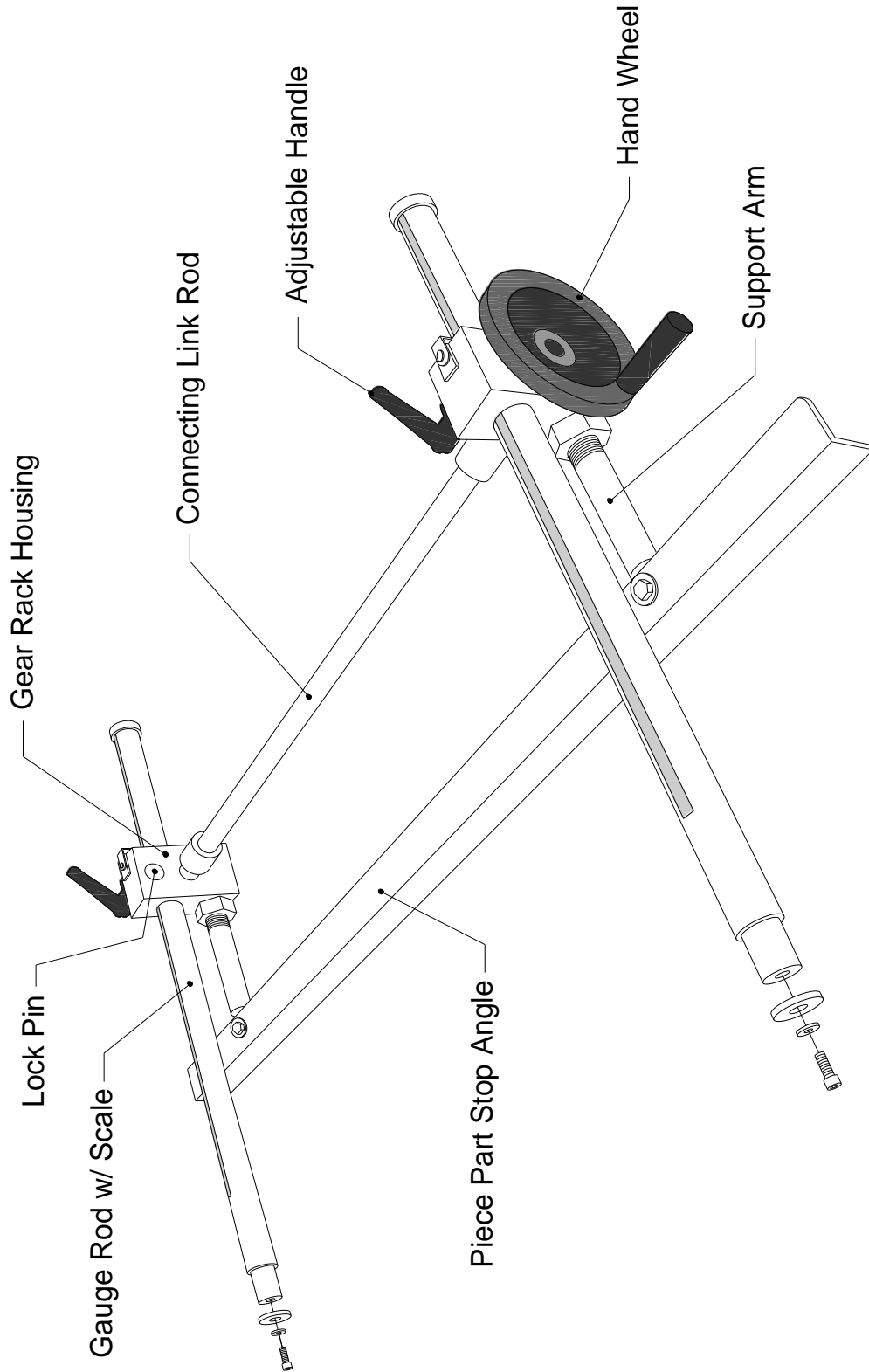

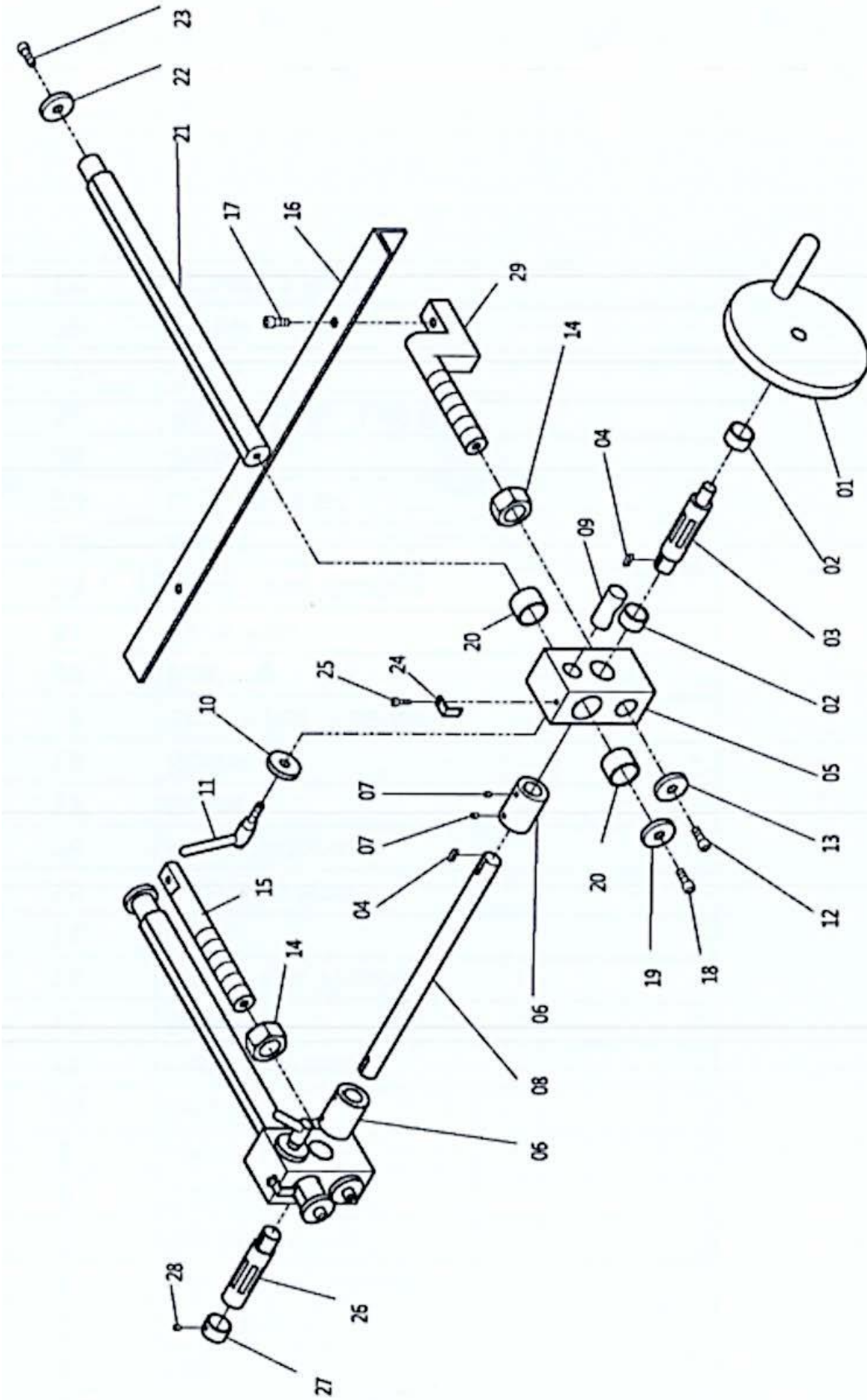



### Back Gauge Parts List - C

Item	Item	Description	Qty.
	SH12010-BACK GAUGE	Complete Back Gauge (items)	
C1	SH-BG-01	Handwheel	1
C2	SH-BG-02	Bushing	2
C3	SH-BG-03	Drive Gear Link	1
C4	SH-BG-04	Key	2
C5	SH-BG-05	Gear Rack Housing	2
C6	SH-BG-06	Connecting Collar	2
C7	SH-BG-07	Set Screw	2
C8	SH-BG-08	Connecting Shaft (Specify Model No.)	1
C9	SH-BG-09	Lock Pin	2
C10	SH-BG-10	Spacer Washer	2
C11	SH-BG-11	Lock Handle	2
C12	SH-BG-12	Cap Screw	2
C13	SH-BG-13	Retaining Washer	2
C14	SH-BG-14	Jam Nut – Full Thickness	2
C15	SH-BG-15	Support Arm Shaft	1
C16	SH-BG-16	Stop Angle (Specify Model No.)	1
C17	SH-BG-17	Cap Screw	2
C18	SH-BG-18	Cap Screw	2
C19	SH-BG-19	Retaining Washer	2
C20	SH-BG-20	Bushing	4
C21	SH-BG-21	Gauge Rod with Scale	2
C22	SH-BG-22	Retaining / Travel Stop Washer	2
C23	SH-BG-23	Cap Screw	2
C24	SH-BG-24	Pointer Angle	2
C25	SH-BG-25	Cap Screw	2
C26	SH-BG-26	Slave Gear Link	1
C27	SH-BG-27	Retaining Collar	1
C28	SH-BG-28	Set Screw	1
C29	SH-BG-29	Support Arm Step Shaft	1



# ELECTRICAL SCHEMATIC - 1

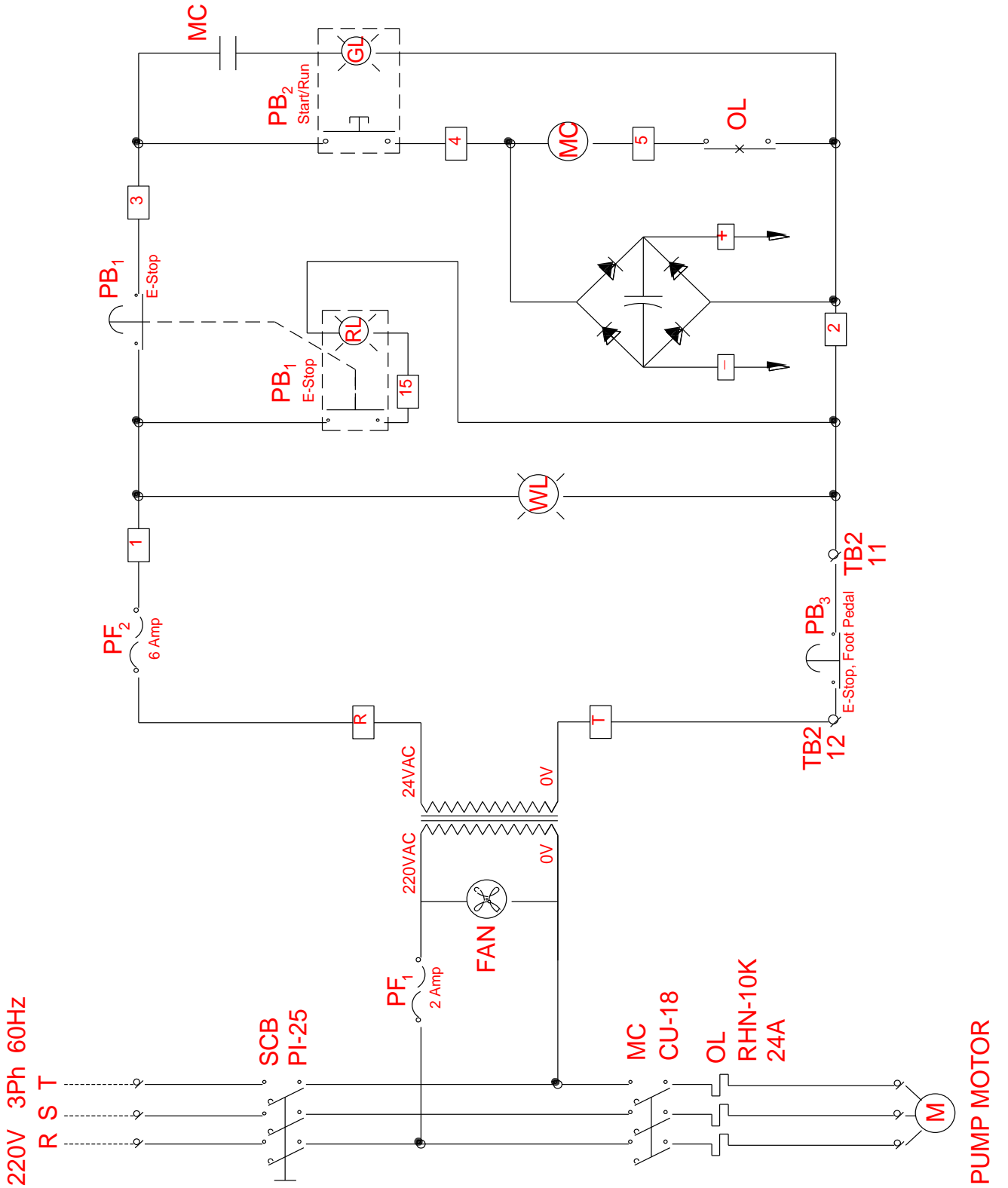



## ELECTRICAL SCHEMATIC - 2

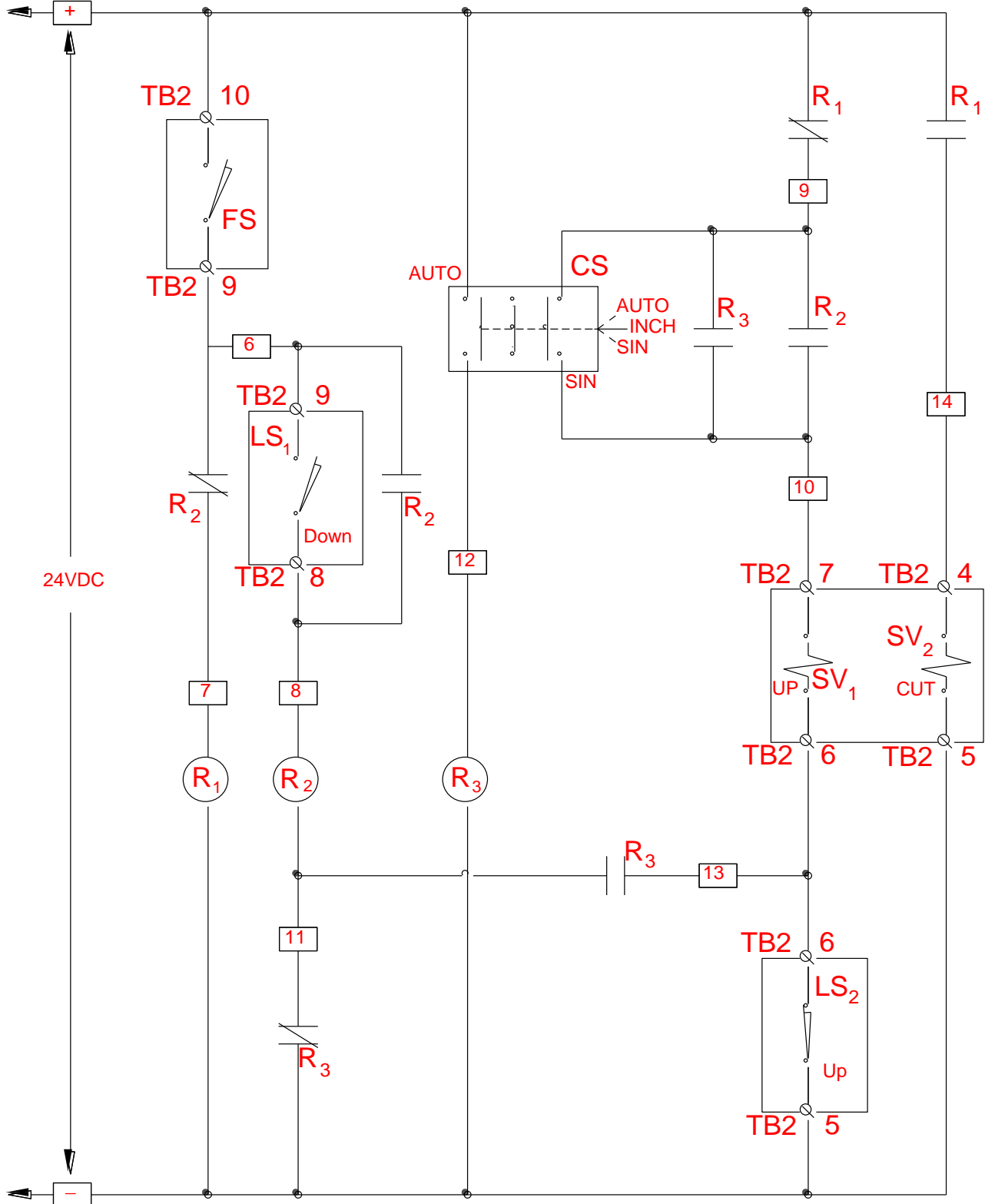



## ELECTRICAL PARTS LIST

Item	Symbol	Part No.	Description	Qty
1	WL	SH5214-60-1	Pilot Light – White 30Ø 24V	1
2	PB2	FT-ON Button	Push Button – Green (Start) with lamp when in run position 30Ø 1A1B 24V	1
3	CS	SH8010-Selector Switch	3 – Position Selector Switch 30Ø 1A1B	1
4	PB1	FT-ESL	E – Stop Push Button (Cabinet) with lamp when pushed 30Ø 1A1B 24V (Lock)	1
	PB3	FT-ES	E – Stop Push Button (Pedestal) 30Ø 1A1B 24V (Lock)	1
5	TR	SH5214-Transformer	Transformer 1Ø 220-440/20-24V 2A 50Hz	1
6	SCB	SH5214-Disconnect Switch	Main Disconnect Switch P1-25/V/SVB	1
7	OL	OL-RHN-10	Overload Switch RHN-10K 24A	1
8	MC	CU-40	Motor Contactor HNO-18 AC 24V 24A	1
9	DCR	BB12010H-Rectifier	D.C. Rectifier, DC 24V 8A 2000uf	1
10	R1- R3	MY-2-AC-24V	Relay MY-2 DC 24V	3
11	PF	FU-2A-38X10 FU-6A-38X10	Fuse 10*38mm 2A Fuse 10*38mm 6A	1ea.
12	FAN	SH6010-FAN	Exhaust Fan 30Øx60St	1
13	TB1	SH5210-13-TB1	Terminal Buss 3P 35A	1
14	TB2	SH5210-14-TB2	Terminal Buss 12P 25A	1
	FS	SH5210-FS5	Foot Switch	1
	LS, LS2	BB12014H-Limit Switch	Limit Switch	2
		SH5210-FP	Foot Pedal Complete	



## ELECTRICAL ENCLOSURE

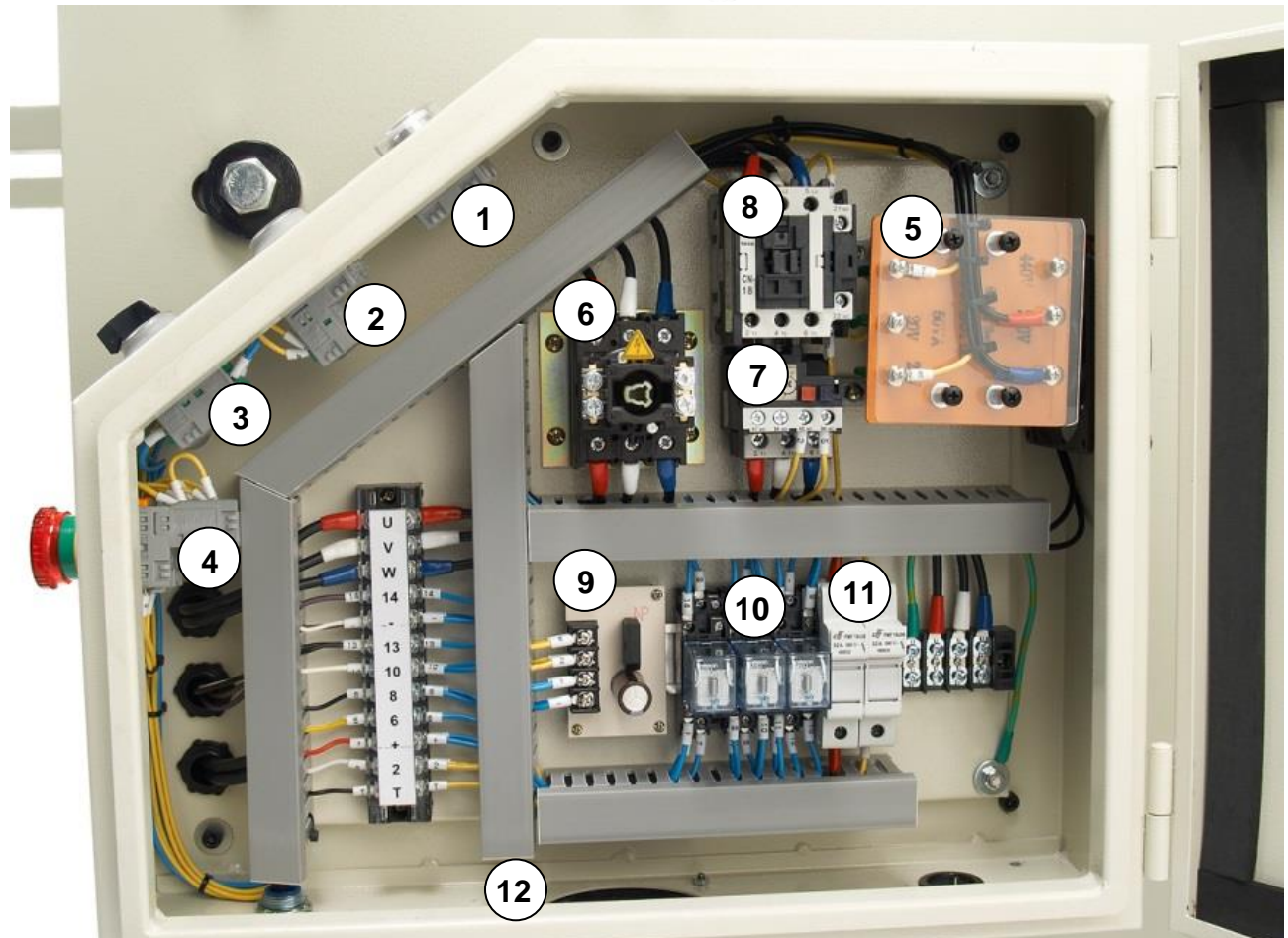



## TROUBLESHOOTING

**⚠ WARNING:** Make sure the electrical disconnect is **OFF** before working on the machine.

FAULT	PROBABLE CAUSE	REMEDY
<b>BURR ON SHEARED EDGE</b>	Dull blades. Excessive blade clearance. Excessive clearance in ram ways. Poor grade of material.	Turn or sharpen blades. Adjust blade gap. Make adjustment to reduce clearance. Select vendor with better quality material that is consistent.
<b>BLADE CAMBER, TWIST, and BOW</b>	Bottom blade not level with table. Not enough hold down pressure. Dull blade.	Adjust blade with shims after grinding. Check springs and hold down pads. Turn or change blade.
<b>KICK BACK of PIECE PART</b>	Bottom blade not level with table. Not enough hold down pressure. Dull blade.	Adjust blade with shims after grinding. Check springs and hold down pads. Turn or change blade.
<b>PUMP MOTOR WILL NOT RUN</b>	No electrical power to the pump motor. Motor burned out. Motor starter does not close.	Check power at source, disconnect off, fuses blown or missing. Reset E-stop Replace motor. Check fuses, start switch, stop switch, motor starter coil, and overloads.
<b>PUMP MOTOR RUNS SLOW</b>	One fuse open.	Replace open fuse.



FAULT	PROBABLE CAUSE	REMEDY
<p><b>PUMP MOTOR RUNS BUT SHEAR DOES NOT OPERATE</b></p>	<p>Electrical circuit open</p> <p>Hydraulic circuit</p>	<p>Check function of foot switch, control relay contacts, down solenoid coil.</p> <p>Check for stuck valve, damaged pump, low pressure, oil bypassing cylinders.</p>
<p><b>BLADE GOES DOWN BUT WILL NOT RETURN TO UP POSITION WHEN FOOT SWITCH IS RELEASED</b></p>	<p>Defective limit switch.</p>	<p>Replace defective limit switch.</p>
<p><b>BLADE GOES DOWN BUT RETURNS SLOWLY TO THE UP POSITION.</b></p>	<p>No hydraulic pressure to lower cylinder.</p> <p>Defective limit switch.</p> <p>Defective "UP" solenoid</p>	<p>Check for stuck valve.</p> <p>Replace defective limit switch.</p> <p>Replace solenoid coil or complete solenoid switch.</p>



NOTES



NOTES



**BAILEIGH INDUSTRIAL HOLDINGS LLC**  
**1625 DUFEK DRIVE MANITOWOC, WI 54220**  
**PHONE: 920. 684. 4990 FAX: 920. 684. 3944**  
**[www.baileigh.com](http://www.baileigh.com)**